

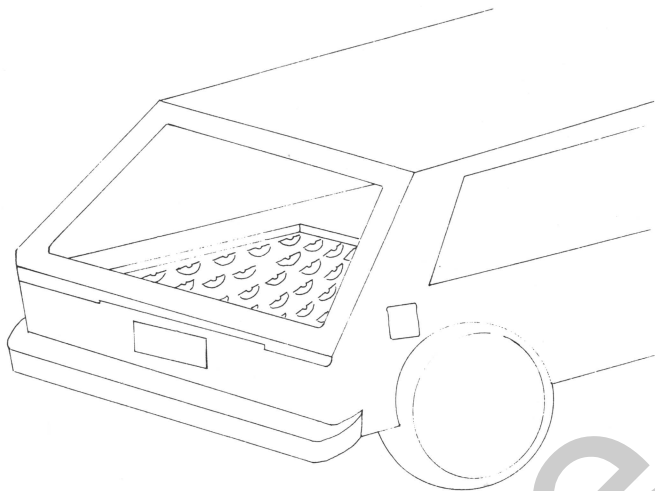

*Published by the University of Missouri-Columbia
Extension Division
College of Home Economics*

Home Dried Food With Natural Heat

*Mildred Bradsher
Food and Nutrition Specialist*



Sun drying requires no artificial heat and very little equipment. It takes continuous days of bright sunshine and low humidity. Sun drying may take several days depending on the dryness of the air, temperature, size of the pieces of food, how the trays are filled, moisture in the food, and the air circulation around the food. Sun drying may be hastened by using a solar dryer described below.

In a solar dryer, clear glass or nonbreakable Plexiglass, tilted toward the sun catches heat. This heat can be trapped inside a box to make a dryer. The dryer should be moved two or three times a day to face the sun. There is more heat when the glass is tilted toward the sun.

The dryer may be made as large or as small as desired and located where it is convenient. Food protected from moist night air dries faster.

A solar dryer must be ventilated for a draft to carry the moisture away from the food. The bottom and sides of the box are open, allowing air to circulate up through the bottom. Air goes out through a top vent at the back. The vents and bottom are best covered with screen to keep out insects and pets. Without ventilation there is danger of too much heat on hot clear days. Heat must not exceed 165 degrees F.

The tray on which the food is placed is best made of openweave cloth or fiber cloth. Metal screen will discolor

food and give a bad flavor. A sheer cloth could be placed on a metal screen but adds another layer to block air circulation.

Other ways to dry without artificial heat include:

In an automobile If it doesn't get too hot, the back deck of an automobile, where the sun shines through the glass, is a good place to dry foods. Crack the windows on both sides for air circulation but not enough to allow insects or birds to enter. Other areas inside the automobile are equally good if sunshine provides temperatures of at least 90 F.

In a warm attic Foods may be dried in a warm attic that has good air circulation. Food may be dried on a tray with air circulation or strung on a line.

Learn to judge whether food is drying correctly by the feel and look of the food. Fruit should be moist to the touch and cooler than the air around it. If not, the heat is too high. If beads of moisture appear on fruit or if it becomes sticky, the heat is too high.

For additional information on drying fruits or vegetables see Home Economics Guides:

1562 Drying Fruits At Home Part I

1563 Drying Fruits At Home Part II

1564 Drying Vegetables At Home Part I

1565 Drying Vegetables At Home Part II

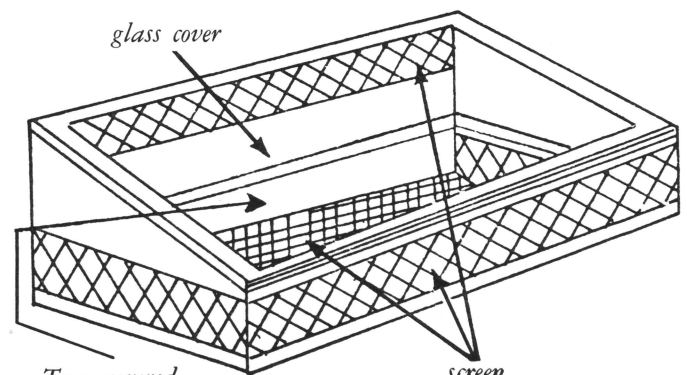

*Tray covered
with cloth or
fiber cloth to
hold food*

Simple solar dryer



■ Issued in furtherance of Cooperative Extension Work Acts of May 8 and June 30, 1914 in cooperation with the United States Department of Agriculture. Carl N. Scheneman, Vice President for Extension, Cooperative Extension Service, University of Missouri and Lincoln University, Columbia, Missouri 65211. ■ An equal opportunity institution.