



*Published by the University of Missouri-Columbia
Extension Division
College of Home Economics*

Shopping for Used Furniture Straight Chairs and Tables

The furniture you choose for your home is one of the biggest investments you make after buying or renting a house. Take time and care when selecting furniture. You'll not only use it for a long time, but also you'll want your family and their friends to enjoy it. Make good use of the money you spend for furnishings by being sure:

- You shop at reliable dealers who will give you information you can depend on.
- You know where you want the piece of furniture to fit. You may need to take some measurements with you. Most pieces will look larger in your home than in the store or showroom.

Advantages of Used Furniture

Some people discard a piece of furniture because it is not the right color, style or size for their room. They may have made a poor selection of quality or style when they bought it.

The mistakes of others may prove profitable for you because you can see some of the weaknesses of used pieces. Wood that was not well seasoned may have warped, cracked or pulled apart. Tables and chairs may have become loose and wobbly if they were not well built. Poor quality finishes may be damaged. You should avoid selection of some of these furniture ills or only consider buying them at a good savings.

Look for Good Construction

Best quality chairs and tables are made of hardwoods such as maple, ash or birch; medium quality of gumwood, elm and mahogany; and lower quality of pine,

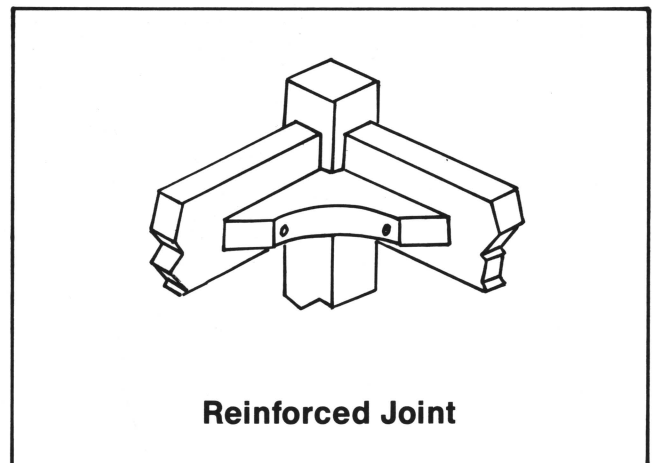
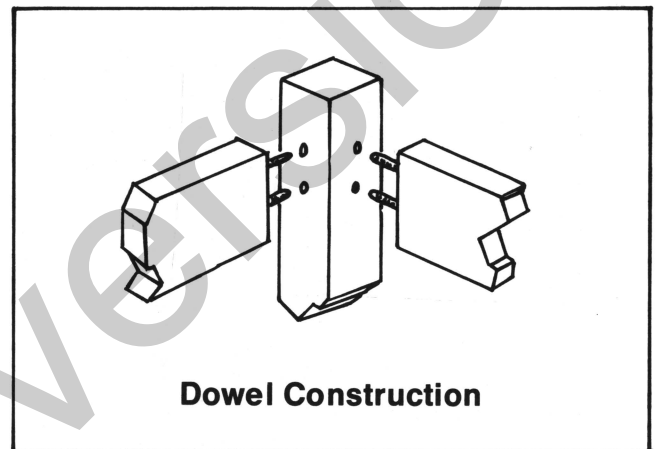

poplar or other soft woods.

Joints in high quality furniture are reinforced with double doweling, dovetailing or corner-braces held with screws and glue. A well-built frame should remain rigid and sturdy throughout the life of a piece of furniture.

Checklist

For Buying Used Straight Chairs and Tables

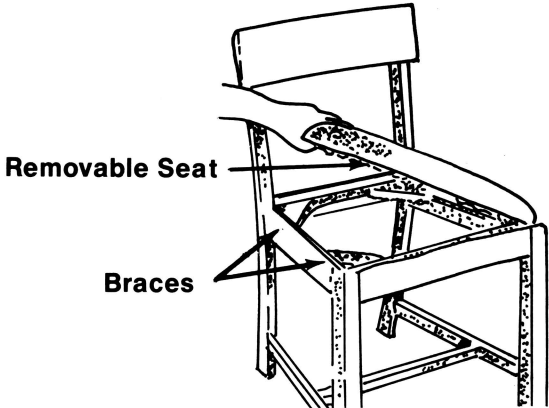
- | | YES | NO |
|---|--|-------|
| 1. Is the piece of furniture sturdy?
Some pieces may be wobbly or shaky. Could the piece be tightened easily with the screws that are already in it?
Look underneath the piece. Does it have the kind and quality of bracing to make it durable? | _____ | _____ |
| 2. Does the piece stand level on the floor? | _____ | _____ |
| 3. If the furniture needs refinishing can you do it yourself?
What would it cost to renovate the piece?
Do you have the materials and tools needed to renovate it? | _____ | _____ |
|  | | |
| | 4. If the chairs have upholstered seats, can you easily remove them for recovering by taking out the screws? | _____ |
| 5. Sit down in the chair. Do your feet fit flat on the floor?
Is the back comfortable for you?
Could you sit in it for a long time without becoming tired?
Do your knees fit comfortably under the table? | _____ | _____ |
| 6. Does the table top have a finish that is easy to care for?
Wood coated with plastic is stain resistant and doesn't damage easily. | _____ | _____ |
| 7. Will the dining table with chairs around it fit into your room?
A space of at least 2½ feet from the edge of the table to the wall is recommended on all sides of the table. This gives room to walk behind each chair when someone is seated at the table. | _____ | _____ |

After you answer all the questions, examine your answers. How many "No's" do you have? If there are several perhaps you'd better look around some more for the furniture you want.