

DETERMINATION OF SCOUR SUSCEPTIBILITY THROUGH RAPID ASSESSMENT

A THESIS IN
Civil Engineering

Presented to the Faculty of the University
of Missouri-Kansas City in partial fulfillment of
the requirements for the Degree

MASTER OF SCIENCE

By
AARON MOORE

B.S. University of Missouri-Kansas City 2009

Kansas City, Missouri
Spring, 2012

DETERMINATION OF SCOUR SUSCEPTIBILITY THROUGH RAPID ASSESSMENT

Aaron Moore, Candidate for the Master of Science Degree

University of Missouri- Kansas City

ABSTRACT

A need existed to efficiently predict the potential scour that could be expected at nearly 20,000 existing off-system bridges in the State of Kansas to assign a National Bridge Inspection Standards (NBIS) Item 113 coding. A customized methodology for scour evaluation was developed through the guidance of TranSystems Corporation, The Kansas Department of Transportation, and the Federal Highway Administration.

This thesis presents a procedure to rapidly assess the scour potential at existing bridges. This procedure consists of a prioritization method and routines to rapidly estimate scour components outlined in FHWA guidelines. Key to the successful implementation of this procedure is all information including bridge plans, historic inspection records, historic photographs, and current photographs were digitized, geo-referenced, and incorporated into GIS software.

This procedure was validated on approximately 300 bridges and, at the time this report was written, has been applied to over 8,000 existing off-system bridges in the State of Kansas. The procedure was beneficial because it is repeatable, the information is easily obtained at a relatively low cost, it requires multiple sets of eyes on every bridge, it is efficient, it accounts for the main scour components outlined within HEC-18, and the results show good correlation with HEC-18 results.

Although this procedure was developed for use in the state of Kansas, it may be applicable for use in other states. However, before doing so an evaluation of the site specific information should be performed and if necessary modifications should be made to the procedure to account for regional issues. The rapid assessment should only be administered by an Interdisciplinary Scour Team having expert knowledge with regards to structural, hydraulic, and geotechnical engineering.

APPROVAL PAGE

The faculty listed have examined a thesis titled “Determination of Scour Susceptibility through Rapid Assessment,” presented by Aaron Moore, candidate for the Master of Science Degree, and in their opinion it is worthy of acceptance.

Supervisory Committee

Jerry Richardson, Ph. D., Committee Chair

Department of Civil Engineering

Deborah Obannon, Ph.D.

Department of Civil Engineering

Jejung Lee, Ph.D.

Department of Geosciences

CONTENTS

ABSTRACT	ii
LIST OF ILLUSTRATIONS	viii
LIST OF TABLES	ix
ACKNOWLEDGMENTS	x
CHAPTER	
1 - INTRODUCTION	1
2 - LITERATURE REVIEW	3
General and Local Scour	3
Long Term Bed Degradation	5
Rock Scour	5
Debris Accumulation	8
3 - PROCEDURE LOGISTICS	9
Bridge Prioritization	9
Monetary Value	9
Local Value	11
Scour Stability Value	12
Data Requirements	14
Owner's Bridge Records Data	14
Field Conditions Data	15
Data Management	25

4 - RAPID ASSESSMENT FOR SCOUR PROCEDURE (RASP)	27
Background	27
Pilot Testing	29
Screening Phases	31
Culverts	33
Single-span Structures	34
Multi-Span Structures with Plans	35
Multi-Span Structures without Plans	36
Procedure Subroutines	37
Rock Scour Procedure	37
Long-term Degradation	40
Abutment Scour	44
Pier Scour	48
Contraction Scour	49
5 - RESULTS AND CONCLUSION	55
6 - RECOMMENDATIONS FOR FUTURE RESEARCH	58
Works Cited	61
Vita	63

APPENDICES

Appendix A: Procedural Flow Chart

Appendix B: Study Area

Appendix C: NBIS Item 113 Coding Maps

LIST OF ILLUSTRATIONS

FIGURE

1 - Age Value Curve	11
2 - Value Rating Distribution Curve.....	13
3 - Photographs at a Culvert.....	17
4 - Photographs at a Bridge.....	18
5 - Photographs at a Bridge.....	19
6 - Culvert Rating Condition.....	22
7 - Measurements at a Bridge	23
8 - Photographing Scour	24
9 - Photographing Scour	24
10 - GIS Application Overview	25
11-Interdisciplinary Scour Team	28
12-District 4 Screening Phase Breakdown	32
13-Common Types of Bridge Construction (Hopkins & Beckham, 1999)	39
14-Factors affecting channel equilibrium. (Federal Interagency Stream Restoration Work Group, 1998).....	42
15-Correction Factor, K_2 , for Angle of Attack (Richardson, 2001).....	49
16-Sketch of Vertical Contraction Resulting from Pressure Flow (Richardson, 2001)	53

LIST OF TABLES

TABLE

1 - Cost Factor Decision Tree	10
2 - Dropdown Measurement Guidance	21
3 - Methodology Comparison Results	30
4- Applicable Screening Procedure Subroutines	32
5-Service Life Criteria	43
6 - Manhour Estimates	55

ACKNOWLEDGMENTS

There are a number of individuals to whom I would like to express my sincere gratitude. First of all is Dr. Jerry Richardson, who has provided invaluable insight and guidance in developing this procedure. My entire educational foundation was formed by Dr. Richardson, who was essentially the reason why I chose water resources as my area of interest in the engineering world. I was fortunate enough to have him for a professor in almost every water related class ranging from Fluid Mechanics to Advanced Sediment Transport Theory. Throughout the years of taking classes under Dr. Richardson I learned a great deal about hydrology and hydraulics theory, writing techniques, and ultimately how to effectively solve problems. Thank you Dr. Richardson for all you have done.

Additionally, I would like to pay tribute to Erich Schmitz for his foresight and guidance in development of this procedure. Erich has been an outstanding mentor to me. His support and encouragement in both my career and studies has definitely enabled me to better understand the importance of professionalism, confidence, and teamwork. I envy Erich's wealth of knowledge and photographic like memory. He has always shown great integrity and has proven that hard work and dedication can take you far in life.

The Kansas Department of Transportation Bureau of Local Projects deserves a ton of credit for essentially funding this research and understanding the importance of the subject matter. The support shown by those guys has allowed the scour evaluation procedure to accomplish fantastic results. Without their help and cooperation, the development of this methodology would not be possible.

A good portion of this research was performed as part of a contract between TranSystems Corporation and the Kansas Department of Transportation. The guidance and support shown by

the TranSystems program manager, Mark Shafer, and TranSystems client manager to KDOT, Tom Swenson, has taught me a great deal about overcoming the political and managerial hurdles a project of this size can present. With their help I have grown a tremendous amount professionally over the last 3 years. I truly appreciate what they have done for me.

I would be remiss if I did not mention my wife and best friend, Kristen Moore. She has supported me throughout many phases of my life and enabled me to become who I am today. Her unconditional love and support throughout our time together has gotten me through many tough stretches. Being married to someone working full time and pursuing a graduate degree means a lot of time apart and she has always been there for me and our children. For that, I cannot say thank you enough!

CHAPTER 1

INTRODUCTION

All bridges crossing water features should be evaluated for scour potential. Scour is the result of the erosive action of flowing water. Flowing water may remove sediment from a channel's streambed and banks, as well as from around the piers and abutments of a bridge causing the bridge to potentially become unstable and fail. As a result of the Schoharie Creek Bridge failure in 1987 the Federal Highway Administration (FHWA) developed a comprehensive methodology that is commonly used to estimate scour depths at bridge foundations.

This report will describe an alternative approach and summarize concepts and procedures developed for a rapid scour assessment at existing off-system structures including:

- Bridge prioritization
- Data requirements
- Data management
- Rapid Assessment for Scour Procedure
- Plan of Action development and delivery

Off-system structures are those owned and maintained by counties, cities, municipalities, etc. The purpose is to ultimately recommend a defensible National Bridge Inspection Standards (NBIS) Item 113 Code and identify bridges that may require a more detailed hydraulic analysis. NBIS Item 113 codes specify a bridge's scour potential with respect to the foundations. The codes range from 0-9 numerically; where 9 would indicate that the foundations are out of flood elevations and 0 indicates that the bridge has collapsed

due to scour. When an Item 113 code is 3 or lower the bridge is classified as being scour critical. Additionally, alphabetical codes of “N” and “U” are possible; where an “N” is not over water and “U” indicates that the foundations are unknown.

The state of Kansas has approximately 20,000 off-system bridges over water. Many of these bridges were built without plans and without a hydrologic and hydraulic study or scour analysis of any kind being performed. Standards for design of highway bridges require that scour depths be calculated for 100-year and 500-year return periods. Off-system structures do not follow these same requirements and many overtop at return periods of 25 years and less. As such, critical depth of flow directly upstream of the bridge associated with incipient overtopping is assumed to be the worst case scenario.

The rapid scour evaluation allowed a large number of existing bridges to be evaluated, in an effort to promote the safety of the traveling public, at a fraction of the cost that would be incurred if a more detailed scour analysis were performed. It is imperative that individuals experienced in relevant fields of engineering apply such evaluations and procedure as there is engineering judgement involved with every aspect of such an evaluation. At the time this report was written, the rapid scour evaluation has been applied to approximately 8,000 of the existing off-system bridges in the state of Kansas.

CHAPTER 2

LITERATURE REVIEW

General and Local Scour

A widely accepted method for determining scour depths at a bridge can be found in the Federal Highway Administration's Hydraulic Engineering Circular 18 often referred to as HEC-18 (Richardson and Davis 2001). This methodology is ideal when designing a bridge as it can help in accounting for scour depths when designing the bridge foundations. However, the methodology outlined in HEC-18 requires detailed data and resources and would assuredly be cost and time prohibitive when applying it to a large number of existing bridges, many of which may not warrant the level of resources required to perform a full hydraulic study. As such, further research was performed in an effort to develop a more feasible solution.

Water-Resources Investigations Report 96-4310 titled "Rapid Estimation Method for Assessing Scour at Highway Bridges Based on Limited Site Data" (Holnbeck and Parrett 1997) was prepared in conjunction with the United States Geological Survey and the Montana Department of Transportation. This document describes studies performed in ten states to develop a relationship between scour depths and the associated hydraulic variables and ultimately generate a rapid-estimation method to predict potential scour at existing bridges.

The rapid-estimation method uses hydrologic, hydraulic, and sediment-transport related engineering concepts to make quantitative scour-depth estimates. Although scour depths can be explicitly calculated using the equations outlined in HEC-18, complex hydraulic variables in some equations cannot be easily measured or estimated in the field.

As such, surrogate variables that could be easily measured or estimated were substituted for the more complex variables in the HEC-18 scour equations to arrive at simpler scour equations. To ensure that the rapid-estimation method would not underestimate scour depths compared to detailed methods, relationships between scour depths and the selected surrogate variables were based on envelope curves rather than best-fit curves (Holnbeck and Parrett 1997).

Many off-system bridges in Kansas are undersized. As such, contraction scour generated from overbank flow may not always govern when it comes to general scour. It may be that pressure flow governs. HEC-18 has an equation for estimating vertical contraction resulting from pressure flow. The equation found in HEC-18 has been found to possess unsatisfactory features as pointed out by Lyn (Lyn 2006). A study performed in 2009 by the FHWA concurs with Lyn's opinion on the Arneson equation found in HEC-18 (Junke, Kerenyi and Pagan-Ortiz 2009). The FHWA study goes on to derive a methodology for pressure flow scour. However, the methodology presented is solely for cases of clear-water which is not presumed to be typical in the majority of streams located in Kansas. Comparing these studies and research, the study where Lyn re-examines pressure flow scour seems to be most applicable for rapidly predicting scour depths at existing bridges experiencing pressure flow.

Many bridge owners have realized the importance of scour protection. Properly designed and installed countermeasures can limit the adverse affect scour can have on a bridge and protect foundations that are deemed as scour critical or unknown. The FHWA has provided guidance on the selection and design of such countermeasures in HEC-23 (Lagasse, Clopper, et al. 2009).

Long Term Bed Degradation

Both aggradation and degradation have negative impacts at bridges. The FHWA has several documents that discuss these issues. HEC-18 lists several factors that contribute to long term degradation (Richardson and Davis 2001). These factors are also discussed in detail in the FHWA Hydraulic Engineering Circular Number 20 (Lagasse, Schall and Richardson, HEC-20 2001). Lagasse et al., state, “Aggradation in a stream channel increases the frequency of backwater that can cause damage. Bridge decks and approach roadways become inundated more frequently, disrupting traffic, subjecting the superstructure of the bridge to hydraulic forces that can cause failure, and subjecting approach roadways to overflow that can erode and cause failure of the embankment.” Furthermore, they discuss that typically, degradation can cause exposure and undermining of foundations, erosion at abutments, and undermining of cutoff walls and bank protection and that “Bank sloughing because of degradation often greatly increases the amount of debris carried by the stream and increases the potential for blocked waterway openings and increased scour at bridges. The hazard of local scour becomes greater in a degrading stream because of the lower streambed elevation.”

Fifteen Federal agencies in the United States collaborated to develop principles, processes, and practices on stream restoration (Federal Interagency Stream Restoration Work Group 1998). The Lane relationship for factors that affect channel equilibrium is referenced within that work.

Rock Scour

The FHWA memorandum titled “Scourability of Rock Formations” (Krolak 1991) encourages designers to conduct sub-surface investigation and use one or a combination of

methodologies to assess the erodibility of the rock. It also recommends that assessment of the formation discontinuity and defects must also be considered. Recommended methods include:

- Rock Quality Determination: a rating of RQD less than 50% is considered erodible.
- Unconfined Compressive Strength ASTM D 2938: strengths less than 250 psi are considered erodible.
- Slake Durability Index- SDI: less than 90% is considered erodible.
- Abrasion AASHTO T96: materials with loss percentages greater than 40 are considered erodible.

There are several issues related to using these procedures when assessing existing bridges for scour potential. The memorandum implies that these methods are ideal for the design of new and replacement bridges. It is not written in a manner that is easily adapted to assessment of a large number of existing bridges. Additionally, the guidelines distinguish what results of these tests indicate erodible rock, but do not indicate what values can be considered to be non-erodible for the remaining life of the structure. It cannot be assumed that the break-point for erodibility is the same as the break-point for non-erodibility.

From the literature, RQD is likely the most applicable test for assessment of potential rock scour. However this method requires obtaining a core sample which is not always feasible for existing off-system structures.

Another methodology published in August of 1998 titled “Prototype Validation of Erodibility index for Scour in Fractured Rock Media” (Annandale, et al. 1998) presents a physical test of materials that has direct correlation to scourability of rock. However, the ability and expense to collect the samples and issues associated with this are similar to the

issues relating to obtaining samples for RQD analysis. Additionally, the methodology was not adopted due to the need for a specialized apparatus to assess the erodibility of the material.

Research performed by the NCHRP as part of project 24-29 titled “Scour at Bridge Foundations on Rock” was examined. The findings of the research were highly anticipated and initially it was intended to review this for adoption. The hope was that this study would provide a viable and cost effective method for assessing scour using data that was easily obtained. However, the methodology relied heavily on RQD values of rock and hydraulic variables such as stream power. As such, even though the methodology presented may be useful for certain applications, this study was deemed as unfeasible for use on a large number of existing off-system structures.

The Kentucky Transportation Center and the University of Kentucky published research report KTC-99-57/SPR 94/157 in September 1999 titled “Correlation of Rock Quality Designation and Rock Scour around Bridge Piers and Abutments Founded on Rock” (Hopkins and Beckham 1999). This report is very comprehensive and was focused on development of a methodology to assess existing bridges founded on rock for scour. In this report it is clear that the researchers were sensitive to minimizing the amount of time and resources required to conduct the evaluations.

Key findings in this report were that procedure can be conducted fairly rapidly and can be used when bridges are founded on exposed rock. Also, the erosion assessment procedure is insensitive to the age of the bridge. This greatly reduces uncertainty in assessing bridge scour in rock. Furthermore, the procedure that was developed assesses scour based on observed conditions using a point system. NBIS Item 113 codes are assigned

based on the scoring system. No samples need to be collected in the field to perform the assessment. This procedure was validated through comparing results with respective RQD values and showed that the assessments maintained a strong correlation with the RQD's. Since underlying geology found in Kentucky are similar to Kansas it is believed that the Kentucky methodology can be successfully implemented in Kansas with some minor adjustments. However, validation was needed. As such, a geotechnical expert familiar with geology throughout Kansas was used to validate assessment results and provide additional input on the likelihood that rock in specific locations would resist potential scour.

Debris Accumulation

The Federal Highway Administration's HEC-18 discusses the affects debris can have on scour depths at bridge foundations (Richardson and Davis 2001). Additionally, Hydraulic Engineering Circular Number 9 referred to as HEC-9 provides information on debris accumulation a presents various methods of controlling debris accumulation at bridges and culvert (Bradley, Richards and Bahner 2005).

CHAPTER 3

PROCEDURE LOGISTICS

The nature of a massive undertaking such as this requires a lot of forward thinking and planning. There are limited resources available and as such, not only was the prioritization of bridges essential, but a plan to collect and manage sufficient data consistently was important.

Bridge Prioritization

The large number of bridges in Kansas required that structures be prioritized to determine the level of effort applied in recommending a NBIS Item 113 code. The bridge prioritization methodology accounts for generalized monetary factors, local importance factors, and a qualitative scour stability score generated by evaluating existing site conditions.

Monetary Value

The monetary factors use bridge geometry and age taken from NBIS data. The bridge geometry information is used to calculate the surface area of the bridge deck and determine a cost per square foot associated with total bridge replacement. A cost factor decision tree, Table 1, was generated to use as a reference in determination of replacement cost per square foot.

Table 1 - Cost Factor Decision Tree

Number of Spans 2 or less				Number of Spans 3 or greater			
Typical KDOT Range	Maximum Span Length	Bridge Type	Cost per sq ft	Typical KDOT Range	Maximum Span Length	Bridge Type	Cost per sq ft
0-20	30	RCB	\$ 85	0-20	30	RCB	\$ 85
15-80	60	Rolled Beam	\$ 110	15-80	40	Rolled Beam	\$ 110
40-100	110	Prestressed Concrete Girder	\$ 95	32-92	90	Reinforced Concrete Haunch	\$ 85
80-200	200	Steel Plate Girder	\$ 150	40-100	110	Prestressed Concrete Girder	\$ 95
				80-200	200	Steel Plate Girder	\$ 150

Based on the bridge deck surface area and the applicable cost per square foot found in Table 1, each multi-span structure was assigned an estimated replacement cost factor ranging from 0-100.

The age of a structure is an important factor in determination of value. As a bridge ages it may require more maintenance than a newer bridge. To assign a consistent age factor to each bridge a depreciation function was developed, Figure 1.

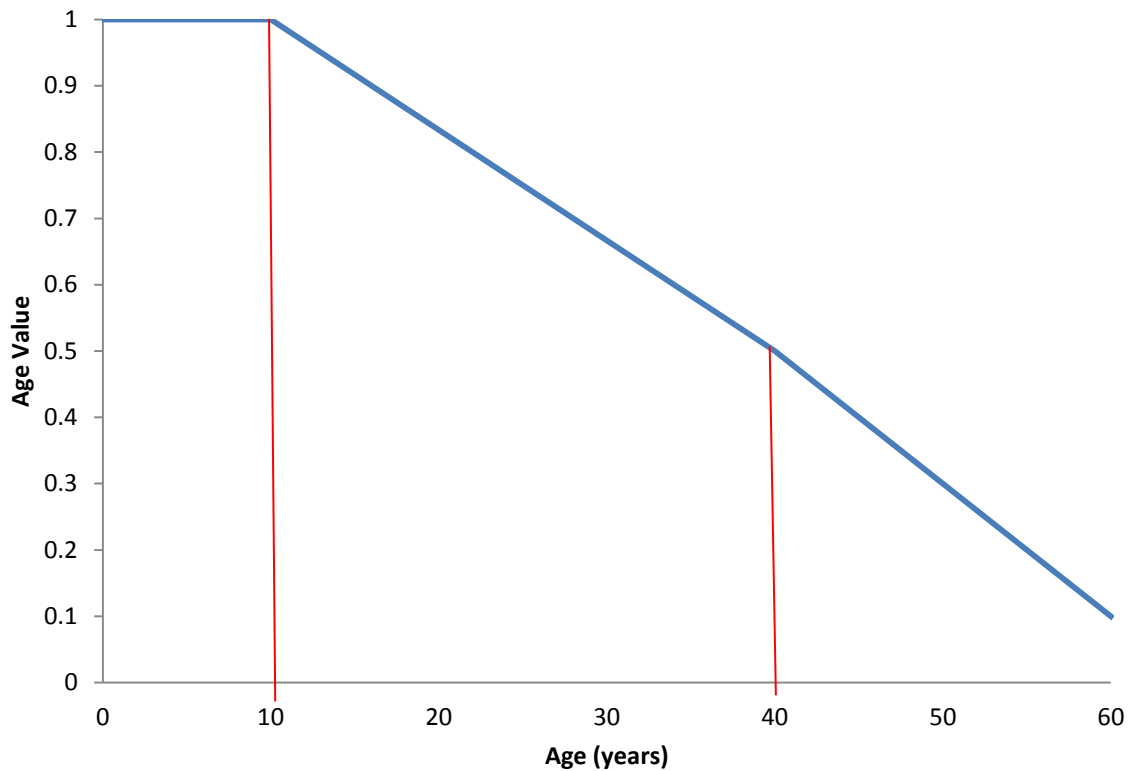

Figure 1 - Age Value Curve

The age factor assumes that the life span of a bridge is 60 years. The first 10 years of life requires very little maintenance and the initial value is retained. Subsequently, the cost of maintenance increases each year which decreases the age value linearly until the bridge reaches 50% of its value at 40 years old. The age value then decreases further to 10% at 60 years old where it remains until the bridge is replaced.

Local Value

The local value factors use roadway classification, average daily traffic (ADT), and percent average daily truck traffic (ADTT) values taken from NBIS data as well as county population information taken from census data. A cumulative ADT is derived by using ADT

and adding a factor taken from the percentage ADTT. It was assumed that every truck is worth 10 cars on these off-system bridges. Truck traffic in these rural settings often indicates that the bridge could be crucial in the economic lifeline for the county.

Scour Stability Value

In the preliminary data collection phase of the statewide project each structure was scored for existing scour condition. Based upon these scores, a qualitative scour value was generated. The qualitative scour stability value ranges from 0-100 where 0 is the most critical value. Many of the poorly scoring bridges are obviously in need of attention and may not be the best candidate for a detailed hydraulic study.

Structure Value Rating

A bridge prioritization value rating has been given to each multi-span structure using the monetary, local importance, and scour stability variables previously described. The value rating allows structures to be prioritized such that an appropriate level of resources is likely to get applied to a given structure. Based on this value rating a distribution curve has been developed for all applicable bridges, Figure 2.

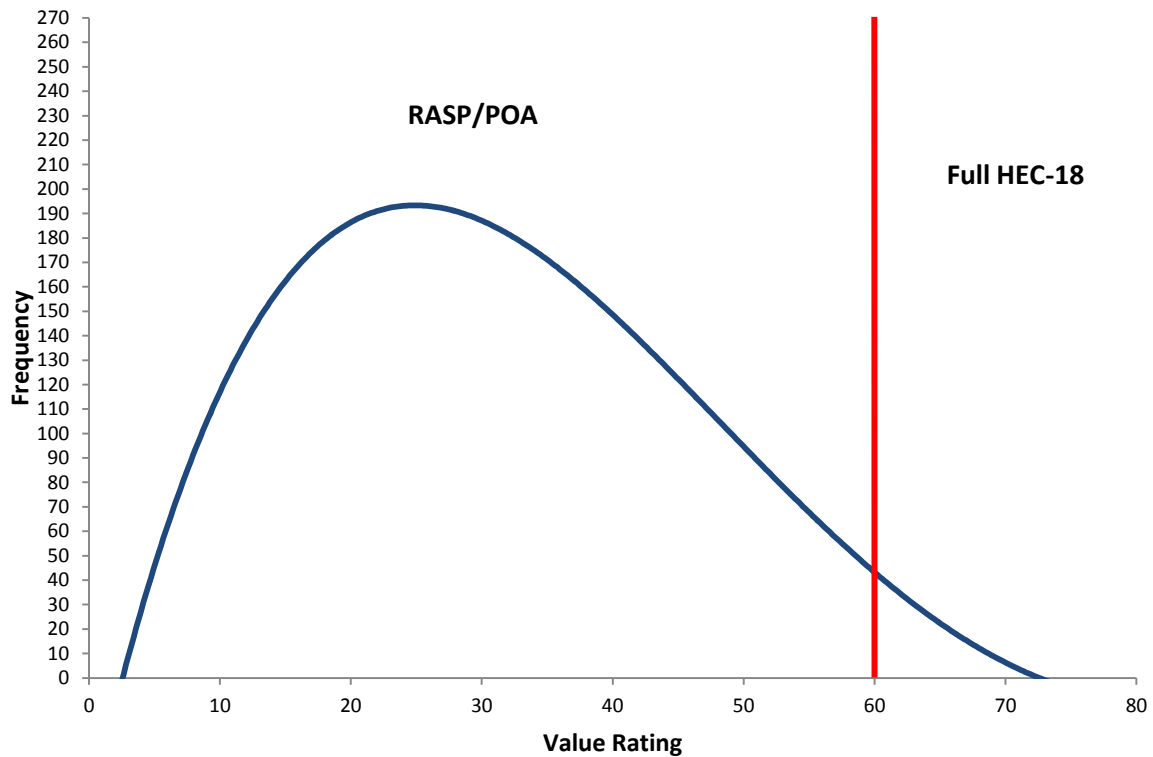

Figure 2 - Value Rating Distribution Curve

The distribution curve allows for a threshold to be determined that will serve as guidelines for resource application. The threshold is depicted in Figure 2 as the vertical line and is dynamic in nature depending on the resources available. As such, if a bridge owner has indicated a particular bridge, deemed as scour critical by the RASP and recommended for closure during a given rainfall event, actually serves a major industry for the local economy then the bridge can certainly be shifted to a higher priority category and potentially receive additional resources. Additionally, some high value bridges may be found to have received a detailed scour analysis during design. In this case, the scour evaluation is

complete for that bridge which could shift the threshold allowing resources to be applied to another structure.

Data Requirements

Owner's Bridge Records Data

The RASP methodology required an evaluation of as much available data from bridge owner records as was readily and reasonably available. As such, the records for the bridges were captured in an electronic format and made accessible to the individuals assessing the structure. The following describes requirements associated with this effort.

- Bridge Plans
 - In general, all bridge plan sheets depicting the current structure were of interest. Bridge Construction Plans and/or As-Built Plans enable quick identification of bridge geometry, foundation depths, foundation bearing material, and in some cases hydraulic design data. Specific sheets of interest were:
 - General/Construction Layout
 - Contour Map
 - Geology
 - Abutment Details
 - Pier Details
 - Channel Change Plans
- Previous Bridge Inspections
 - Previous bridge inspections provided a means of investigating the bridge's hydraulic and structural history. Any notes and forms that were available

from previous bridge inspections were beneficial to the evaluation.

- Historic Photos
 - Historic photographs provided historic site conditions for comparative cross-section studies and datums for evaluating Long-Term Bed Degradation.
- Underwater Inspection Reports
 - Some bridges had received Underwater Inspection Reports. These reports often contained channel cross-section data and foundation condition information that was valuable for evaluating the structure's scour potential.
- Maintenance Records
 - Bridge maintenance is essential to extending the life of the structure. Any existing maintenance records helped provide a general understanding of issues that had occurred in the past and how those issues were addressed.
- Hydraulic Modeling Data
 - Some bridge packets included output from hydraulic modeling software used during the design of the bridge. This data provided vital information and insight during the scour assessment.

Field Conditions Data

The RASP methodology also required the evaluation of existing conditions at each bridge regarding scour and channel stability. To complete this work, the following field data was obtained:

- Site Photographs
 - Current photographs of each bridge depicting site specific conditions were essential in the evaluation. The existing site conditions were captured through

geo-referenced photographs with embedded GPS data coordinates and direction. This eliminated the need for creating a photo log and allowed the photographs to be incorporated into GIS software. Figures detailing the minimum required photograph locations for culverts and bridges are shown in Figure 3, Figure 4, and Figure 5 respectively.

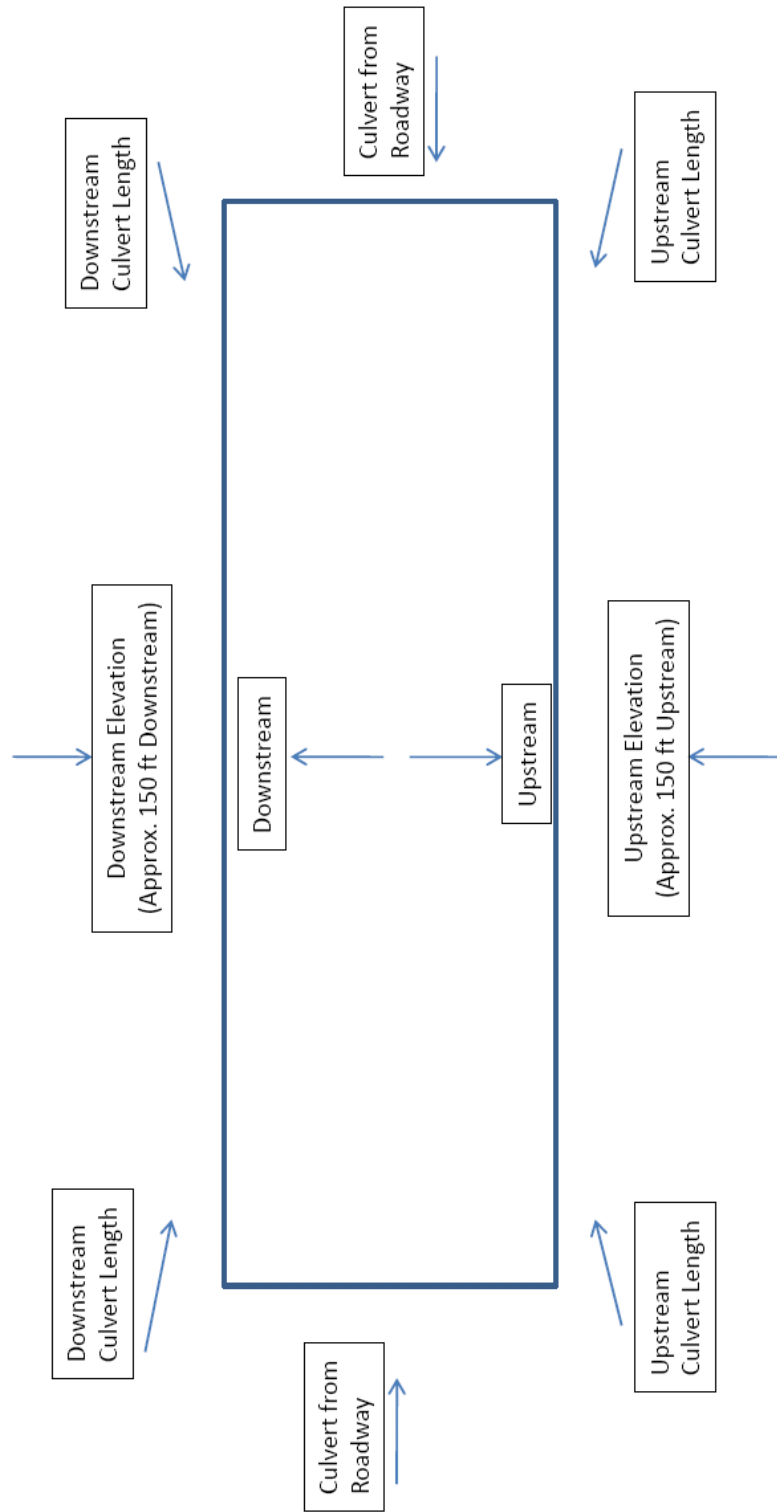

Figure 3 – Minimum photograph locations at a culvert

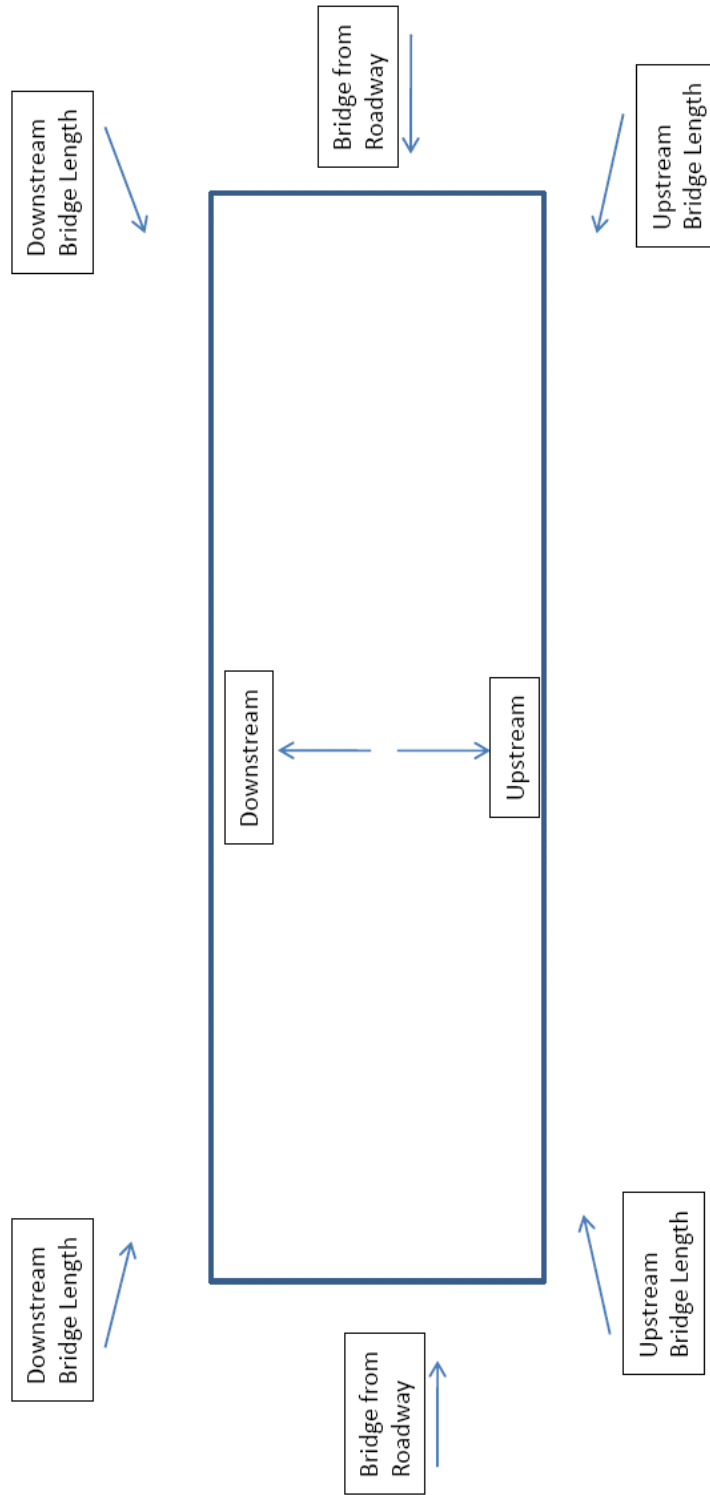

Figure 4 – Minimum on deck photograph locations at a bridge

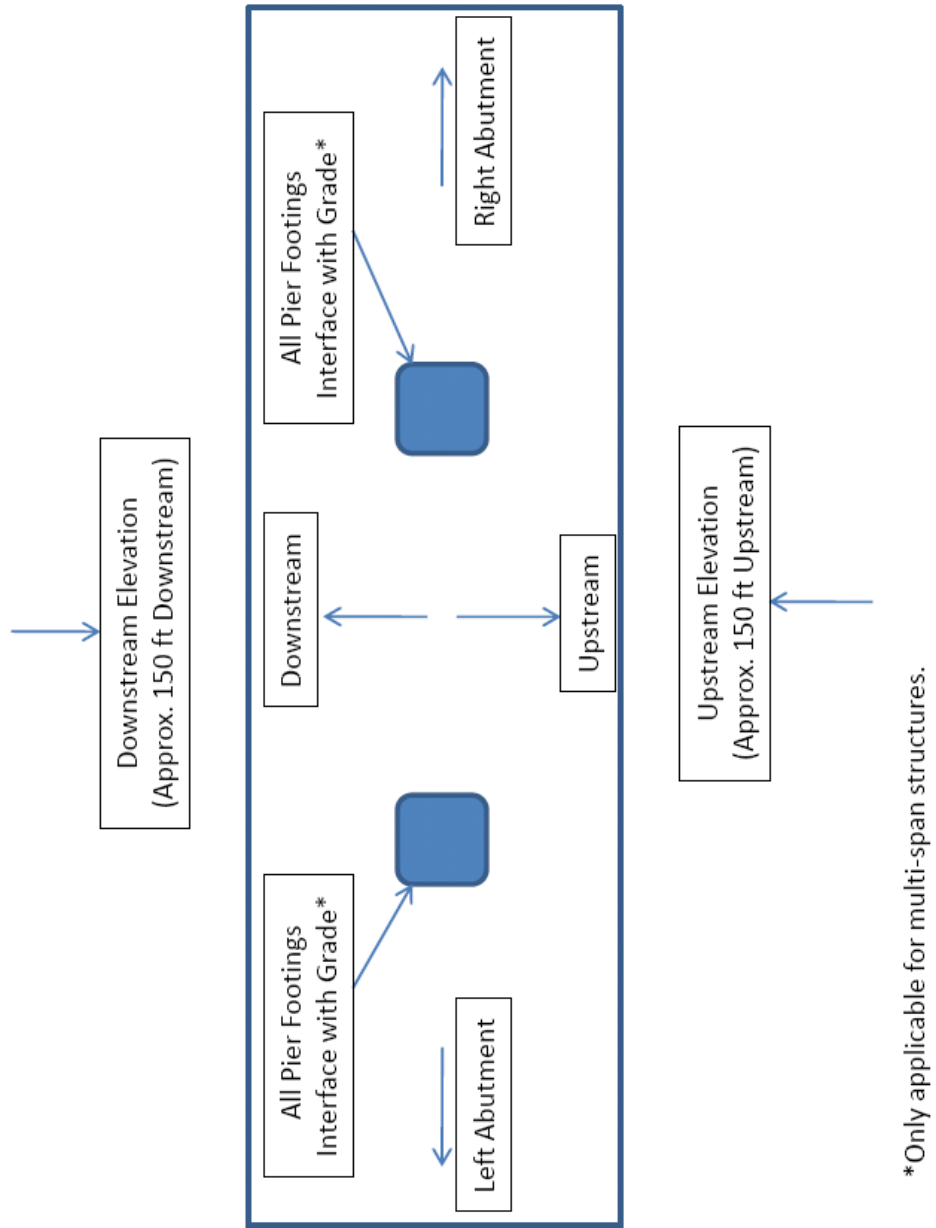

Figure 5 – Minimum below deck photograph locations at a bridge

- Measurements
 - The number of measurements required to be taken at a structure was dependent factors such as; structure type, size, and condition.
 - At culverts, a verification of the current NBIS Item 62 (Culvert Condition Rating) and Item 61 (Channel Condition Rating) was required. Item 61 rating verification was completed by referencing the bridge inspection manual (Kansas Department of Transportation 2012) and following the guidelines described within. Item 62 rating verification was done by probing along the upstream and downstream toe walls and documenting the depth of scour, see Figure 6.
 - At bridge structures, probing around substructure foundations and documenting the depth of scour (if any) supplemented the photographs taken and verified scour in scenarios where water in the channel prevented observing the substructure condition.
 - Depending on the previously described bridge prioritization rating, some multi-span structures required measurements at the upstream fascia to capture a cross-section of the channel in addition to substructure probing. In doing this, the deck thickness was documented and the streambed elevation measured relative to the top of deck at fixed points along the bridge. These “dropdown” measurements were started at the left abutment and proceeded at the increments shown in Table 2.

Table 2 - Dropdown Measurement Guidance

Total Bridge	Dropdown
0-50	5
50-200	10
200 +	25

These measurements were used to compare the existing cross-section against previous measurements to document any general lowering of the channel bed. Figure 7 illustrates the general concept of capturing this data.

Typical tools required when collecting field measurements include a 4 foot probe, a 25 foot fiberglass survey rod, and a measuring wheel or tape. When significant scour was present, photographs of the conditions were taken using a survey rod as a scale, Figure 8 and Figure 9.

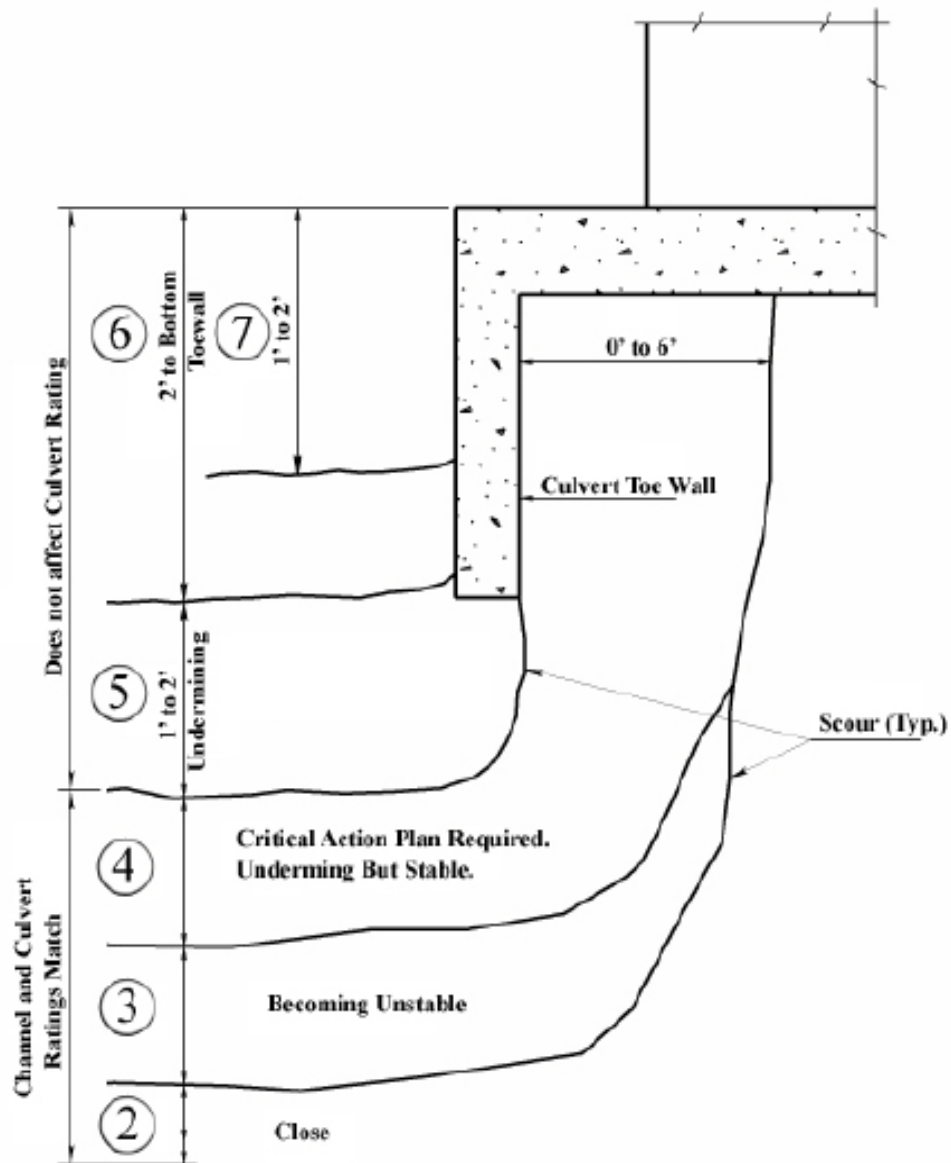

CULVERT / CHANNEL RATING

Note:

- 1) Culvert/Channel rating applies to worst case at either "entrance" or "exit" end of culvert.
- 2) Scour must be full width of the opening.
- 3) Unstable wings, due to scour will lower culvert rating to a "7" and a channel rating to a "6".
- 4) Failed wings, due to a scour will lower culvert rating to a "6" and a channel rating to a "6".

Figure 6 - Culvert Rating Condition (Kansas Department of Transportation 2012)

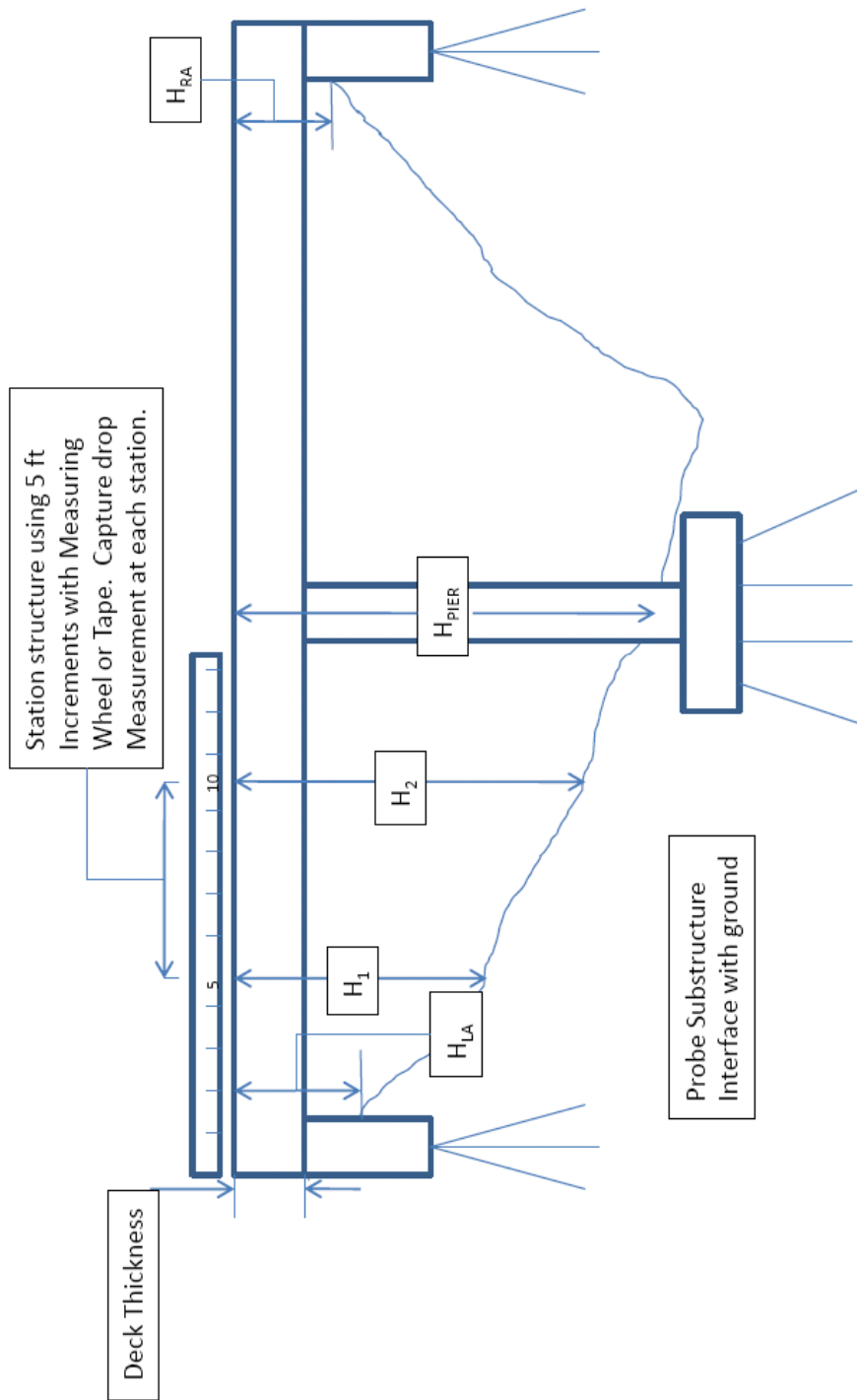

Figure 7 - Measurements at a Bridge



Figure 8 - Photographing Scour



Figure 9 - Photographing Scour

Data Management

Collecting the previously described data was highly important to the success of the RASP. However, managing the data in a manner that allowed easy access and interpretation was equally valuable. As such, a database solution that incorporated geographic information system technology, also known as GIS, and a consistent file structure was developed. This served many different roles in the screening process as well as managerial benefits that allowed easy progress reporting and status updating.

The coordinates of each structure were verified and associated with the corresponding NBIS structure number. This allowed for each structure to be spatially referenced in a digital map and made available to necessary individuals throughout an evaluation. Each structure is represented by an icon that is linked directly to the specific structure's records and plans if they were available, Figure 10.



Figure 10 - GIS Application Overview

Furthermore, aerial photographs, topographic maps, and available FEMA data were incorporated into the GIS application. This allowed the structures to be viewed in a dimension other than simply at the ground which enabled an overall analysis of the hydrologic and hydraulic system associated with each structure.

The example shown in Figure 10 depicts the icon representing the structure as well as several arrows. The arrow shows the location and direction that each photograph was taken. Each arrow was linked to the representative photograph and was easily accessed with the click of a mouse. The benefit to using photographs that are geo-referenced presents itself here. Assessing thousands of bridges generated thousands of photographs and bringing them into this type of system precluded the need for photo logs which reduced the time required to collect and catalogue the data.

Without such a robust data management system this type of undertaking would have likely been impossible as one could easily lose track of information. Furthermore, good data management allows the procedure to be efficient and organized.

CHAPTER 4

RAPID ASSESSMENT FOR SCOUR PROCEDURE (RASP)

Background

The purpose of this procedure was to recommend a methodology that will rapidly assess the susceptibility for scour and identify bridges that would require a more detailed hydraulic analysis. A widely accepted scour analysis method outlined in the Federal Highway Administration (FHWA) Hydraulic Engineering Circular Number 18 (HEC-18) requires detailed data and resources, which could be cost and time prohibitive to perform on a large number of existing bridges. As a comparison, a typical scour evaluation takes about 5 hours to complete. More detail about the time required for the assessment is discussed later in the document.

The rapid assessment must be administered by an Interdisciplinary Scour Team having expert knowledge with regards to structural, hydraulic, and geotechnical engineering (Richardson and Davis 2001). Utilizing the skills of such a team helped ensure the rapid assessment procedure was applied properly to each bridge and the assumptions associated with such an assessment had appropriate engineering judgment and experience supporting them. Figure 11 illustrates the organizational structure of the Interdisciplinary Scour Team.

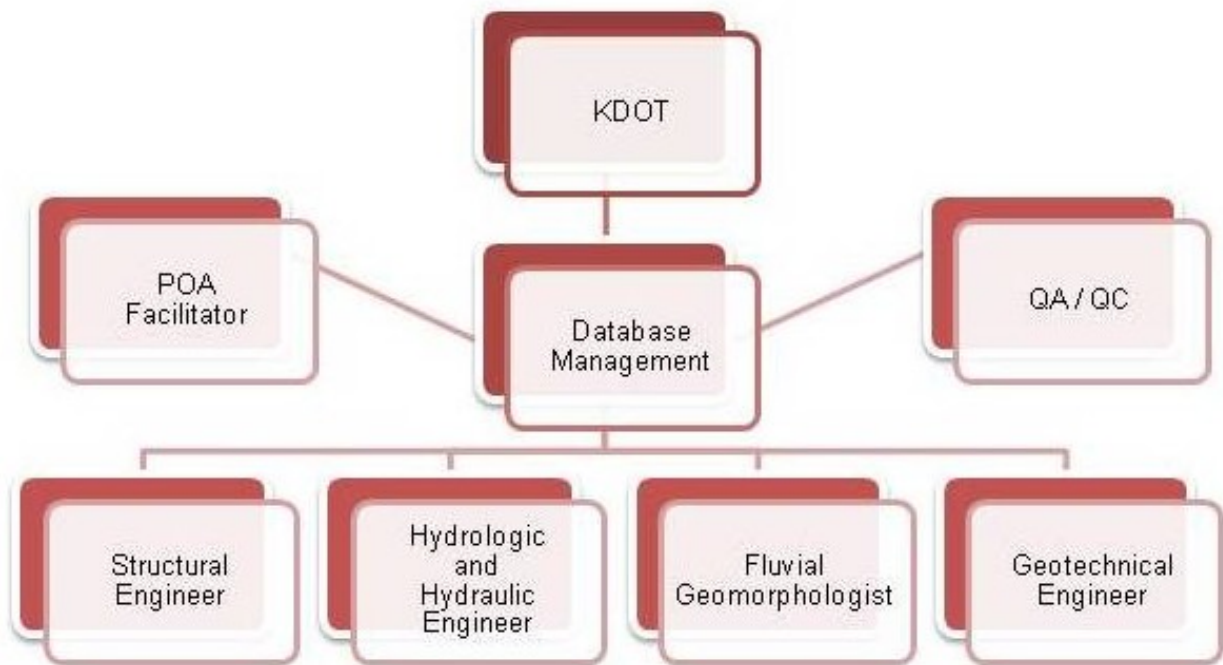

Figure 11-Interdisciplinary Scour Team

The rapid scour assessment procedure described within this document estimates the primary components of scour found within the scour analysis procedures outlined in HEC-18. These estimates were considered conservative based on the assumed conditions that would likely occur during a flood event. In most cases, required site data for the rapid assessment procedure were easily obtained from the following sources:

- Phase I data
- Aerial Imagery
- USGS topographic maps
- Historic and recent photos
- Field inspection records
- Bridge construction plans

The goal of this procedure was to identify scour susceptible bridges and recommend countermeasures to improve the safety of the traveling public. In addition, this procedure was used to recommend a NBIS Item 113 Code.

The rapid assessment procedure was not meant to be as comprehensive as a more detailed study, such as HEC-18, and is not intended for use as part of the design of a new structure. However, by applying this procedure to existing off-system bridges whenever possible, the number of bridges requiring a full HEC-18 analysis was dramatically reduced.

Pilot Testing

To validate the rapid assessment procedure, a sampling of bridges with completed detailed HEC-18 scour analyses was assembled. The sample bridges were then assessed using the rapid assessment procedure. The results were compared, and the variability of the results was examined. Based on these variances, adjustments were made to the rapid assessment procedure until the results were in general agreement. The main contributor to the initial variances found in the pilot testing resulted from the conservative nature of the pier scour methodology found within the 1997 USGS methodology (Holnbeck and Parrett 1997). The RASP was modified to replace that methodology with the CSU equation found in HEC-18 (Richardson and Davis 2001). This modification required that some engineering assumptions be made and these are described in more detail in the pier scour section of this document. The final results of our pilot testing are presented below in Table 3.

Table 3 - Methodology Comparison Results

Structure Type	Location	No. of Spans	Max Span (ft)	Pier Width (ft)	HEC-18			RASP		
					Pier Scour (ft)	Contraction Scour (ft)	Total Scour Depth (ft)	Pier Scour (ft)	Contraction Scour (ft)	Total Scour Depth (ft)
Multi-Span Steel Girder with Drilled Shaft Substructure	Riley County Kansas	3	49	4	9.8	0.6	10.4	9.6	2	11.6
Multi-Span Box Girder with H-Pile Substructure	Pulaski County Missouri	5	28	2	7.2	1.8	9	6.9	2.8	9.7
Multi-Span Double Cell Box Beam with H-pile Substructure	Hall County Nebraska	4	35	6.5	7.6	1	8.6	8.6	1.6	10.2
Multi-Span Double Cell Box Beam with H-pile Substructure	Hamilton County Nebraska	28	60	7	18.9	5.6	24.5	21.9	4.2	26.1
Multi-Span Steel Beam with Concrete Cap on Pile Substructure	Sedgwick County Kansas	5	100	3	8.7	7.5	16.2	9.1	9.5	18.6

It is important to note that with respect to the comparison abutment scour and long term degradation was not evaluated. This is due to the nature of those assessments being qualitative rather than quantitative. As is described later in this document, the abutment procedure relied on the location of the abutment with respect to the channel along with other

key factors. Long-term degradation relied heavily on the history of the bridge and engineering judgment.

Further testing of the rapid assessment procedure was performed on approximately 300 off-system bridges located in KDOT District 4. This area was chosen because many of the structures are close enough for easy access and also because we had knowledge of the flood history in that area and generally knew how the structures have performed. Based on that familiarity, the RASP results from these bridges were found to be in good correlation with what was observed during major storm events.

Screening Phases

Figure 12 illustrates the initial anticipated breakdown of bridges in Kansas that could be assessed using each of the developed screening phases. This was based on the data collected within the Kansas District 4 area and it was assumed that the off-system bridges in the remaining KDOT districts would follow a similar distribution, leaving approximately 10% of the total bridges requiring a detailed analysis.

RASP Breakdown

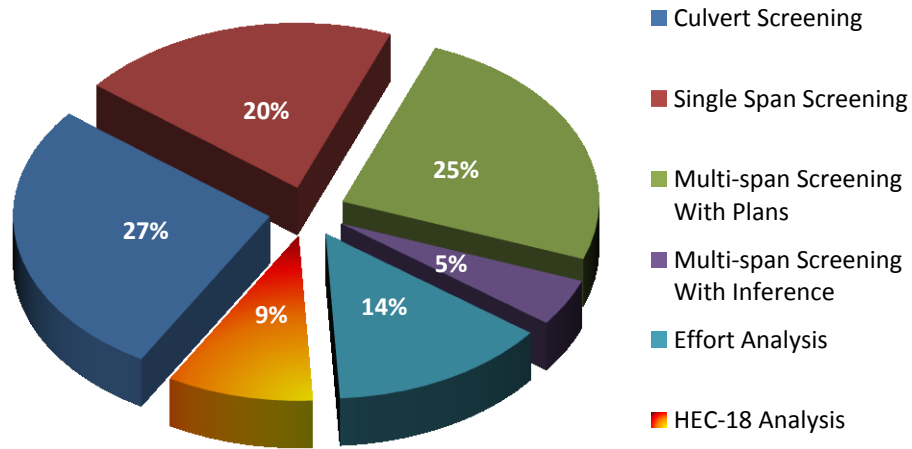

Figure 12-District 4 Screening Phase Breakdown

The screening phases shown in Figure 12 illustrate the basic overview of the rapid assessment procedure and are described in the following subsections. Each phase utilized specific procedure subroutines essential for rapid assessment of scour susceptibility. Table 4 summarizes the applicable procedure subroutines associated with each screening phase.

Table 4- Applicable Screening Procedure Subroutines

	Long-term Degradation	Abutment Scour	Pier Scour	Contraction Scour	Rock Scour
Culvert	●*				
Single-span		●			●
Multi-span with Plans	●	●	●	●	●
Multi-span without Plans	●	●	●	●	●

* *If applicable*

The procedure subroutines shown across the top of Table 4 are described in detail in the section of this report titled Procedure Subroutines. The structure types shown in the rows of Table 4 each have specific subroutines that are applicable. The structure types are described as follows.

Culverts

In the state of Kansas, the term culvert refers to two types of structures depending on whether you are discussing the structural or hydraulic characteristics of the structure. For the purpose of the hydraulics associated with this procedure, culverts are defined as follows:

- Concrete Pipes
- Metal Pipes
- Four-sided concrete box structures which contain an integrated concrete floor

A culvert consisting of multiple pipes where the clear distance between the openings is less than half of the pipe opening was considered a continuous structure and measured from the outer pipe edges. The term integrated concrete floor suggests the floor was part of the initial design of the structure and not placed post-construction as a scour countermeasure. If the structure is a three sided box or lacks an integrated concrete floor, the structure was assessed as a bridge. Post construction concrete placed can be determined by visual inspection. A culvert could be assessed using photographs taken during the field inspection.

The recommended Item 113 code for a culvert was contingent upon the overall condition and ratings of NBIS Item 61 (Channel Condition Rating) and Item 62 (Culvert Condition Rating). This is a combination of hydraulic and structural components based on conditions upstream, downstream and at the structure. Generally, codes for Item 61 and Item 62 were on a rating scale of 0 to 8 where a rating of an 8 indicates a good condition and 0

indicates a critical condition. The individual components within the ratings were appropriately weighted for its potential effects on the culvert and were evaluated to reflect current conditions based on the most recent field review. Furthermore, these ratings considered the potential for head-cuts, channel migration, or other stream stability issues that could threaten the structure. More detailed guidance on stream stability is outlined within FHWA HEC-20 (Lagasse, Schall and Richardson, HEC-20 2001).

Debris accumulation at a culvert was considered when coding the condition ratings. Debris accumulation at the entrance of a culvert leads to a variety of problems such as, increasing the potential for scour, affecting the hydraulic adequacy of the culvert, and increasing flow velocity around the debris. Additional information on debris accumulation and its adverse affects is discussed in detail in the FHWA HEC-9 (Bradley, Richards and Bahner 2005).

Single-span Structures

A large portion of the off-system bridge inventory in Kansas consisted of single-span bridges. These structures typically had abutments set at or near the existing channel banks. As such, single-span screening consisted only of the Abutment Scour Procedure. The potential for long-term degradation, lateral stream stability issues, and contraction scour was also considered within this procedure.

In some cases the abutments were founded on rock that had become exposed. As such, it was evident that the abutment foundations were on rock and the Rock Scour Procedure was also used to assess scour susceptibility. The recommended Item 113 Code was based on the lower of the codes obtained in the Abutment Scour Procedure and the Rock Scour Procedure.

Multi-Span Structures with Plans

Structures that have multiple spans have multiple potential failure modes with respect to scour. Understanding the foundation design of these types of structures was important when assessing the potential for scour to affect the structural stability. For the purposes of this procedure there were three distinct scour cases.

1. Spread foundations are on exposed rock

The Rock Scour Procedure was used to assess the scour susceptibility of the bridge. If the bridge was not scour critical by this assessment, the Abutment Scour Procedure was then performed. The Item 113 Code was recommended based on the lower of the codes found in these two procedures.

2. Spread foundations are assumed to be on rock, and the rock is not exposed.

If the construction plans indicated spread foundations keyed into rock but the rock was not visible during inspection, a Rock Scour Procedure was still completed if a bridge within a reasonable geographic proximity had a completed Rock Scour Procedure. The bridge would adopt those results from the Rock Scour Procedure. The Abutment Scour Procedure was also performed. The Item 113 Code was recommended based on the lower of the codes found in those procedures.

In the event that there was not a nearby bridge that had a completed Rock Scour Procedure, the Abutment Scour, Pier Scour, Contraction Scour, Pressure Flow Scour, and Long Term Degradation Procedures was administered. The accumulation of values from these procedures determined whether a geotechnical expert should evaluate the bridge in an effort to gain a general understanding of the subsurface geologic conditions at the bridge location. The bridge received a

cursory geotechnical evaluation by an expert familiar with the geology of the area if the applied scour procedures have indicated the total scour depth is below the foundations and bridge is scour critical. The Item 113 Code was recommended based on the geotechnical evaluation.

3. Piling foundations or spread foundations on erodible material.

This case required the accumulation of values found in the Long-term Degradation, Pier Scour, Contraction Scour, and Pressure Flow Scour Procedures. If the total scour depth is such that the bridge was not scour critical then the Abutment Scour Procedure was completed. For all bridges that had scour depths exposing a significant length of pile, a structural stability assessment was performed. The Item 113 Code was recommended based on the lower of the codes obtained in those procedures.

Multi-Span Structures without Plans

Many bridges were either built without detailed construction plans and/or the construction plans have been misplaced or destroyed. These particular bridges have unknown foundations and potentially cannot be assessed for scour vulnerability. The FHWA has required these bridges with unknown foundations to receive an Item 113 Code of U and issuance of a Plan of Action (POA). However, the FHWA has identified other acceptable methods, such as inference, to assess bridges with unknown foundations.

For bridges categorized as low risk, it may be more cost-effective and efficient to use alternate methods for inferring foundation characteristics necessary for scour evaluation. A bridge categorized as low risk would be one that has traditionally performed well, has no history of scour, and closure would have a minimal affect on the community.

The goal of the inference method is to estimate unknown bridge foundations by evaluating bridge foundations similar in:

- Age
- Construction
- Geology
- Location

Taking these items into consideration; if two bridges were similar, the foundations are likely also similar. These bridges were assessed for scour using the same procedure subroutines as the multi-span bridges that have construction plans available, and if found to be not scour critical, an Item 113 Code of 5 was recommended. Bridges having inferred foundations do not require a POA for unknown foundations. The Interdisciplinary Scour Team evaluated inference methods carefully prior to use and ensured that risk potential for the bridge was adequately quantified and addressed (Lwin 2009).

Procedure Subroutines

Rock Scour Procedure

The rock scour subroutine was developed using a modified version of the Kentucky rock scour procedure (Hopkins and Beckham 1999). This procedure was applied, when necessary, on all structures except culverts.

Background

The ability of a bridge founded on rock to withstand scour depends on the scour resistant nature of the rock on which the piers and abutments are founded. The complexity of rock scour has led to multiple studies conducted by academic institutions and highway research organizations to quantify the susceptibility of rock scour.

Information was gathered providing a means to identify the most likely rock types at the bridges being assessed for scour. This information includes publicly available geo-referenced shape files, websites, and publications of geologic formations. The following resources are listed in order of preference to identify the subsurface geology at a specific bridge:

- Bridge Construction Plans
- Geotechnical expert review
- USGS Geological shape file
- Geological survey historical & surficial geology shape file
- Construction materials and boring logs
- State Highway Commission Form 619

Procedure

In cases where rock had become exposed at bridge foundations, a visual inspection of the rock was performed. Typical span arrangements and foundation details for these cases are illustrated in Figure 13 and included:

- Multi-span bridges with the pier located on rock with abutment located on point bearing piles resting on rock
- Multi-span bridges with pier and abutments founded on rock
- Single-span bridges with abutments located on rock.

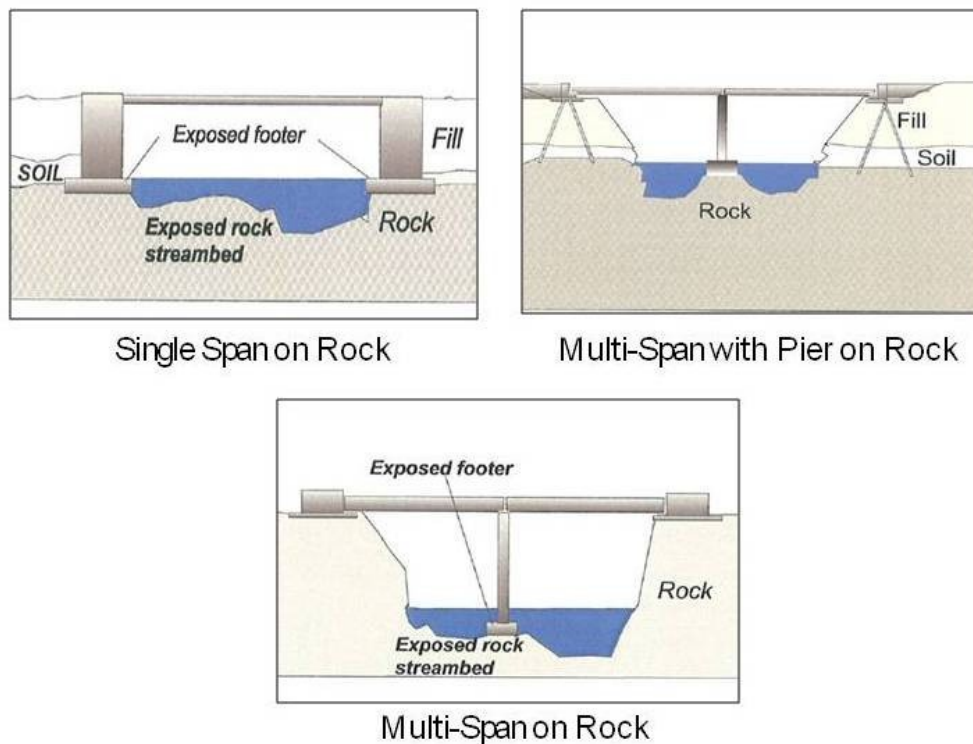

Figure 13-Common Types of Bridge Construction (Hopkins and Beckham 1999)

Factors that were considered during the visual inspection of rock scour include: scour proximity, depth, penetration, as well as rock type, weathering, and condition.

- Proximity refers to the general location of rock scour in the streambed and its relative position to the substructure footing.
- Depth of scour refers to the distance from the ambient rock line to the bottom elevation of the exposed substructure footing. Should the depth of scour reach vertically below the footing, then an additional depth of scour was taken into account.
- Penetration of scour determines the present horizontal distance from the face of the substructure footing to the eroded face of the rock unit.

- Weathering refers to the mechanical breakdown of rock due to freeze/thaw. The thickness of sedimentary layer increases/decreases rocks sensitivity to weathering.

Visual inspection included the area around the exposed footing.

Long-term Degradation

Long-term degradation affects the stability of all structure types. This is accounted for in the evaluation of culverts and single-span structures qualitatively. For multi-span structures, a more quantitative approach was taken.

Background

“Aggradation and degradation are the vertical raising and lowering, respectively, of the streambed over relatively long distances and time frames” (Lagasse, Schall and Richardson, HEC-20 2001) and are affected by sediment continuity within the stream reach. Degradation will occur when there are deficits in sediment supply as compared to the sediment transport capacity of the reach, unless there is a control present which limits the erosion. Such controls can be natural or man-made and consist of geologic outcroppings, coarse sediments which form an armor layer, and grade control structures. HEC-18 lists some factors that affect long-term bed elevation changes (Richardson and Davis 2001):

- Dams and reservoirs
- Changes in watershed land use
- Channelization
- Cutoffs of meander bends
- Changes in the downstream channel base level
- Gravel mining from the streambed

- Diversion of water into or out of the stream
- Natural lowering of the fluvial system

These factors are also discussed in detail in the FHWA Hydraulic Engineering Circular No. 20 (Lagasse, Schall and Richardson, HEC-20 2001).

In 1955 E. Lane developed a qualitative relationship between four basic factors which affect streambed equilibrium commonly referred to as Lane's Balance. These factors are sediment discharge, median sediment particle size, stream flow, and stream slope. That relationship, illustrated in Figure 14, can be used to evaluate long-term bed elevation changes. For example, if a bend in a stream is cut off to change channel alignment for construction of a bridge, the stream slope will be steepened which will likely send the stream out of equilibrium into a state of degradation. Once the streambed returns to its stable slope or reaches a layer of coarser sediment, it may again arrive at a state of relative equilibrium.

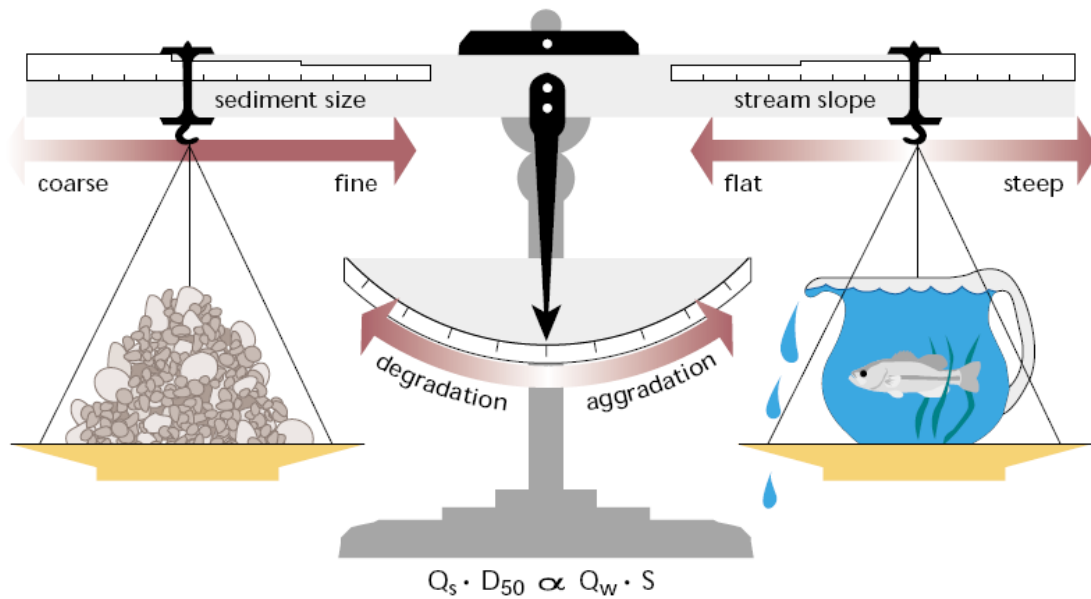

Figure 14-Factors affecting channel equilibrium. (Federal Interagency Stream Restoration Work Group 1998)

Procedure

When evaluating long-term degradation (LTD) as a portion of total scour at a bridge, the remaining design life of the bridge was taken into consideration as well as any mitigating factors that may be in place to arrest or reverse degradation such as; countermeasures, grade control structures, rock layers, selective sorting armoring layers, or downstream base level conditions (reservoirs, lakes, detention, etc). First, an estimate of the rate of degradation was established; then, this rate was multiplied by the remaining design life of the bridge, shown in Table 5, to obtain any additional depth of scour attributable to LTD. This value was subsequently added to the other components of scour at the structure to obtain an estimate of the total scour depth. It should be noted that LTD may not be constant throughout the bridge's life span. For example, recent urbanization in the upstream watershed may cause

rapid degradation in a short time period when the bridge had previously been in a state of relative equilibrium; or, over previous decades, degradation may have occurred at a relatively constant rate until an armoring layer of coarser sediments was reached and little to no additional degradation would be expected. Engineering judgment was crucial in assessing LTD.

Table 5-Service Life Criteria

Age of Structure	Service Life Remaining for Scour Assessment
1-10 years	60 years
11-20 years	50 years
21-30 years	40 years
31-40 years	30 years
41-50 years	20 years
Over 50 years	10 years

Abutment Scour

The abutment scour procedure is a qualitative assessment that is applied to all structures with the exception of culverts. This assessment accounts for multiple factors that would contribute to scour and erosion at an abutment substructure.

Background

Many off-system bridges are located in rural areas and were designed to minimal hydraulic standards. As such, cases where abutments are located within a channel and impinge on free surface flow are common and the potential for abutment scour must be assessed. The methodology used to assess the potential for abutment scour consists of a scoring system that quantifies factors that affect an abutment's scour susceptibility. These factors were easily attainable by utilizing current and historic photos of the site as well as specific information found during the field visit.

Procedure

When applying this assessment the reviewer considered the following factors:

- The abutment type

The type of abutment at a bridge is important when considering bridge hydraulics. For example, when all other factors are equal, a spill through abutment type is significantly more efficient hydraulically than a vertical wall abutment.

- Abutment protection

An abutment with proper countermeasures in place will likely resist scour more than an abutment that is unprotected. As such, it is imperative that countermeasures are used to protect the soils supporting the abutment

foundation. Countermeasures for abutment scour are described in HEC-23 and include (but are not limited to) embankment revetment and guidebanks. Abutments that were unprotected received higher scores in the assessment scoring worksheet. In addition, any observed deterioration of abutment protection was taken into account during the assessment and additional points were given to the bridge.

- The abutment location and foundation depth

The location of the abutment in relation to the channel relates directly to the abutment scour rating of the bridge. Bridges in which abutments are outside of the channel are less likely than bridges with abutments in the channel to experience abutment scour, particularly if the abutment is protected.

The importance of foundation depth varies with the relative location of the bridge abutment with respect to the stream channel (considering potential lateral migration of the channel). Abutment scour concerns for protected abutments on shallow or unknown foundations that are set substantially back from the stream channel are less than the concerns for abutments set closer to the channel. Because of this, it may be possible for an unknown or shallow abutment foundation to be assessed as having less scour potential provided countermeasure protection is in place.

- Influence of Piers Adjacent to the Abutment.

Piers located on an abutment fill slope or at the toe of an abutment fill slope could contribute to potential scour issues due to the local pier scour. As such,

bridges with no piers or piers that are located more than 20 feet from the toe of an abutment fill slope received lower scores in the assessment.

- Abutment fill slope greater than 2H:1V

Research and experience has shown that a minimum 2H:1V slope is recommended for slope stability (based on angle of repose and other factors). Slopes steeper than 2H:1V can experience stability issues during flood events. Additional points were given to bridges that have abutment fill slopes steeper than 2H:1V.

- Observed exposure of abutment piling or undermining.

Exposed substructure for a bridge is an indication that erosion, scour, or long-term bed degradation is occurring. When the foundation piling for an abutment is exposed, additional points were given to the bridge.

- The potential for long-term degradation and lateral migration (stream stability issues).

Stream bed degradation and lateral migration are important when the abutments are near the stream bank or project into the channel. The procedure for determining if degradation is a contributing factor can be found in the subsection titled Long-term Degradation located in this report. Recent and historic bridge photos, aerial imagery, and HEC-20 (Lagasse, Schall and Richardson, HEC-20 2001) guidance were reviewed when considering the potential lateral migration.

- Observed movement of the abutment.

Vertical cracks in the abutment or separation gaps between girders and abutment caps are typical indicators that movement has occurred. Observed movement in an abutment automatically classified the bridge as scour critical.

- Contraction Scour

Contraction scour is generally additive to the abutment scour depths regardless of bridge type (single or multiple spans). Although the assessment procedure for abutment scour accounts for the potential for combined contraction/abutment scour, the abutment scour score may be modified upward when abutments are located near the stream bank, project into the channel, or when additional considerations are noted. These include:

- Abutment fill slope steeper than 2H:1V
- Observed exposure of abutment pile
- Observed degradation
- Undermining of abutment
- Observed deterioration of abutment protection
- Movement of abutment
- Lateral migration threatens bridge

Pier Scour

Pier scour contributes to the cause of many scour related bridge failures. The location, geometry, and foundation type of the pier can increase the amount of scour anticipated and resultant stability of the substructure.

Background

During flow events, bridge piers can obstruct stream flow increasing velocity which results in channel bed material to be removed from around the pier foundation. However, pier scour holes are sometimes difficult to observe as the scour holes tend to be filled during the receding limb of the hydrograph. The potential for pier scour is dependent on several factors including pier geometry, pier location compared to the channel, and flow alignment to the piers.

Procedure

The procedure uses the CSU equation described in HEC-18. To estimate the local pier scour, the Froude number was assumed to be a value of one unless enough data existed to determine otherwise. The average pier width was determined through either bridge plans or field measurement. The correction factor (K_2) was equal to 1.0 if flood flows are relatively aligned with the piers. If the piers were subject to poor flow alignment (greater than 15 degrees skew), HEC-18's Correction Factor (K_2) was adjusted according to Figure 15.

Angle	L/a=4	L/a=8	L/a=12
0	1.0	1.0	1.0
15	1.5	2.0	2.5
30	2.0	2.75	3.5
45	2.3	3.3	4.3
90	2.5	3.9	5.0
Angle = skew angle of flow L = length of pier, m			

Figure 15-Correction Factor, K_2 , for Angle of Attack

(Richardson and Davis 2001)

It is important to note that the above simplification of the Froude Number assumed critical depth of flow directly upstream of the bridge opening. If there was concern that a supercritical flow regime was occurring at the bridge location, a full HEC-18 analysis was performed to better quantify local velocities and subsequently estimate pier scour depths. Additionally, if the rapid assessment was perceived as overly conservative, a hydraulic analysis was conducted to review the Froude number to potentially limit the calculated scour at piers.

Contraction Scour

The contraction scour subroutine was one of the more difficult to apply. This procedure relies heavily on conveyance variables associated with a structures upstream waterway. Having construction plans as well as aerial and digital topographic information was highly valuable to the success of this procedure.

Background

This section details the methodology recommended to rapidly determine general contraction scour including estimation of pressure flow contraction scour. The procedures

presented in the following subsections summarize a means of predicting reasonable scour depths using limited or minimal hydraulic and site data. As is the case for rapid scour assessment for piers, abutments and long-term degradation, this procedure was developed such that the results should be more conservative than if a more detailed hydraulic/scour analysis was conducted in accordance with HEC-18.

Contraction scour is the most common component of general scour (a thorough description is presented in HEC-18). When the bridge deck is inundated pressure flow scour occurs. The recommended rapid assessment procedure estimates both of these types of contraction scour. It should be noted that general scour also encompasses bed elevation changes related to plan form changes, flow in bends, or other changes that decrease the bed elevation at a bridge. These other aspects of general scour are non-quantifiable (whether or not a detailed HEC-18 analysis is used) but must be considered based on engineering judgment of each site on a case-by case basis.

General Contraction Scour

According to HEC-18, contraction scour is a complex hydraulic process that occurs over time when a bridge contracts the flow of a channel (Richardson and Davis 2001). Additionally, contraction scour is often cyclic in nature, meaning that the bed will tend to degrade during the rising limb of a flood hydrograph and refill during the flood recession. Conditions that may contribute to contraction scour at a bridge include:

- Abutments impinging on the channel
- Piers blocking a large portion of the natural flow area
- Bridge approaches blocking floodplain flow

Common methods to determine the potential magnitude of contraction scour are documented in HEC-18. Two equations are recommended depending on whether or not the flow is expected to be either clear-water or live bed. Live-bed contraction scour occurs when the stream is carrying bed material from the upstream channel bed through the bridge section. The scour that results at the contracted bridge section is due to the balance between the sediment transport capacity into the bridge section and the new sediment transport capacity through the bridge section (Richardson and Davis 2001). The increase in sediment transport capacity through the contracted bridge section is caused by the higher velocity in the channel due to the contraction. Scour holes created under live-bed conditions are those that typically refill during the recession stage of a flood.

Clear-water contraction scour occurs when there is no transport of bed material from upstream or suspended material being carried through the contracted bridge section (Richardson and Davis 2001). The scour that results at the contracted bridge section is due to increased velocity through the bridge exceeding the critical velocity for the dominant particle size of the channel bed material. Typically, clear water scour holes will often be preserved after the flood as there is little to no sediment transport from upstream available to refill the scour holes.

The conditions for clear-water scour require that the average velocity in the channel, upstream of the bridge, are lower than the velocity required to transport the sediments that comprise the stream bed. This means that clear-water scour conditions depend on the bed material size. For clear water to control, approach flow velocities would have to be very low if the stream bed was sand and fine gravel.

In sand/silt channels where sediment is most likely transported into the bridge section, the previously discussed live bed-scour equation, was used. Where gravel/cobble bed material is prevalent, and sediment deficient water is anticipated, a clear-water scour method should be considered but is not presented in this study. However, because contraction scour can be assessed as the lesser of the clear-water or live-bed condition (J.R. Richardson Personal Communication) and because live-bed will be more conservative if applied to a clear-water scenario (i.e. scour will not be limited as a function of bed material size), only the live-bed estimate is considered for the RASP.

Procedure

The variables required for the equations presented in HEC-18 require the collection of data that, in many cases, was not easily obtained. Therefore, methods to simplify these computations to provide reasonable, yet conservative contraction scour estimates were investigated. The United States Geological Survey conducted a study in 1997 (Holbeck and Parrett 1997) developing and documenting a method for rapid estimation for scour at bridges. The methodology presented from this research was adopted for use in the RASP. With respect to the conditions typical in Kansas, live-bed conditions were assumed to govern. In the USGS study the live-bed contraction scour equation was reformed using the principles of conveyance so that flow rates were replaced by geometric variables. With the existing bridge plans and photos, and field inspection notes, reasonable estimates of the bridge geometries and flow depth variables was possible. The result of the procedure is a scour depth. When applying this procedure it was possible to obtain a negative value. For use in the RASP negative values were assumed to be zero contraction scour.

Pressure Flow

Many off-system bridges experience pressure flow frequently. This is evidenced in the photographic evidence of numerous bridges with debris (logs, sticks, twigs, mud, old tires and other debris) lodged in the bridge superstructure. Other structures may be more difficult to identify as having the potential for pressure scour. Pressure flow is a vertical contraction that occurs when the water surface elevation of the stream rises to or above the low member of the bridge resulting in an increase in cross-sectional velocity. The increase in velocity results in a higher sediment transport capacity. Pressure flow can influence the local scour depths at a pier or abutment making them larger than for free surface flow. Figure 16 shows the vertical contraction that can result from pressure flow.

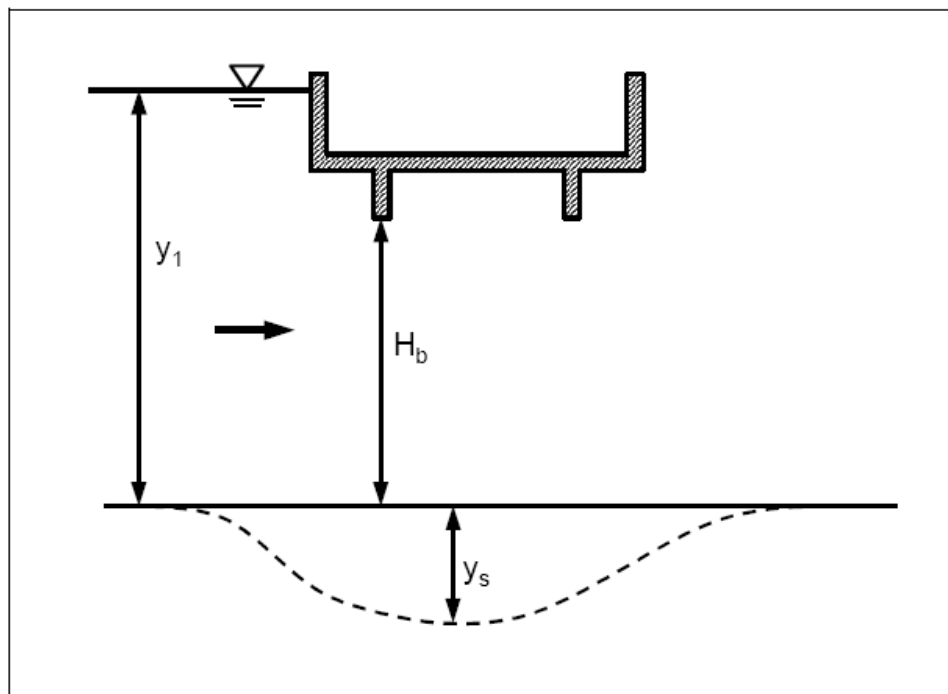

Figure 16-Sketch of Vertical Contraction Resulting from Pressure Flow (Richardson and Davis 2001)

Procedural Summary

Just as the case for contraction scour, there are few methods for estimating the scour depths resulting from pressure flow. Three existing methods were examined and evaluated for feasibility for use in the state of Kansas. The alternative approach proposed by Lyn utilizes a power law equation for estimating a scour depth based on a one-sided prediction interval. This approach was adopted for use in the RASP.

General contraction scour and pressure flow scour were treated and presented separately. In some cases, when assessing for contraction scour, it was found that it is not obvious whether to apply the general contraction scour subroutine, or the pressure flow scour subroutine. In such cases, both were calculated and engineering judgment was used on which value to apply. Although, the larger value may be considered to govern.

CHAPTER 5

RESULTS AND CONCLUSION

The RASP provides a means to evaluate existing bridges over water for scour. The end result of this procedure is to achieve a justification to an appropriate NBIS Item 113 code for a bridge that may have never received a scour analysis during design. The procedure has been tested and calibrated on over 8,000 of the 20,000 plus off-system bridges located in the state of Kansas. This process allowed a large number of existing bridges to be evaluated at a fraction of the cost that would have been incurred if a more detailed scour analysis were performed. Throughout the process of screening, the total amount of hours required to evaluate the bridges was tracked. This included all hours associated with the procedure, from data collection through the screening and Plan of Action development if necessary. The results of this are shown below in Table 6.

Table 6 - Manhour Estimates

<i>Number of Bridges 8242</i>		
Methodology	Total Estimated Manhours	Manhours per bridge
RASP	41,828	5.1
HEC-18	1,030,250	125

The total manhours associated with the RASP were tracked, whereas the total manhours associated with performing a HEC-18 on each bridge is an estimate. The manhours required to apply a methodology to each bridge were then calculated by simply dividing the total hours by the number of bridges evaluated.

Based upon the manhours comparison shown in Table 6, an estimated cost associated with the RASP was found and compared to the estimated cost associated with performing a HEC-18 analysis. The results of this comparison indicated that the HEC-18 methodology is approximately 20 times greater in cost than the RASP.

By examining the results we obtained within our initial comparison of scour depths associated with each of these procedures, presented in Table 3, and the cost associated with each procedure we found that the RASP is both effective and cost efficient when applied to existing bridges. The cost per bridge of the RASP is over 20 times less than that of the HEC-18 analysis.

One important aspect of the procedure to note is, while the RASP is intended to provide an evaluation of existing bridges, there are some scenarios where the interdisciplinary scour team may determine that the procedure is not applicable. A prioritization was developed with the RASP to allow structures that are high value to be considered for a more detailed study, such as HEC-18. In addition to the higher value bridges, some structures may have unique or complicated hydraulics such as very large bridges over major rivers with overflow structures. The hydraulics associated with these kinds of scenarios could prove to be beyond the capabilities of the RASP. As such, it is recommended that a more detailed methodology be used in evaluating the potential for scour at these types of structures.

A definite benefit to the RASP is that it required each bridge to be looked at by several different individuals having expertise in multiple areas of discipline and, if necessary, receive a POA. Most states have a bridge inspection program. However, one driving factor behind the development of this procedure was that many inspectors were not familiar with

the consequences associated with scour and the NBIS Item 113 was not accurate. Having each structure thoroughly evaluated has brought resolution to many issues that were previously not noticed or documented. This alone provides value to the bridge owner as well as the traveling public.

This procedure has been successfully implemented on approximately 8,000 of the existing off-system bridges in Kansas. I am calling this procedure a success for the following reasons:

- It is repeatable
- The information is easily obtained at a relatively low cost
- It requires multiple sets of eyes on every bridge
- It is efficient
- It accounts for the main scour components outlined within HEC-18
- Provides a basis for evaluation during the prescribed inspection cycle
- The results show good correlation with HEC-18 results.

CHAPTER 6

RECOMMENDATIONS FOR FUTURE RESEARCH

While each evaluation subroutine requires engineering judgement and the documentation of applied assumptions, some subroutines may benefit from future research. As such, in the process of developing the RASP, there were some specific areas where future research should be performed to potentially improve the overall procedure. These areas include but are not limited to:

- Unknown foundation
 - A large number of the bridges may not have detailed information regarding the foundation depth and type. There are currently a number a methods to determine this information in a non-destructive manner. However, many of these methods are very costly and do not always have desirable results. Further research should be performed to determine the viability of other, more efficient, methods to determine a reasonable foundation type and depth at bridges where otherwise the structure may require the implementation of a Plan of Action for unknown foundations.
- Large river crossings
 - As previously mentioned, there can be complex hydraulics associated with crossings over major rivers. The RASP, as it is, may not be applicable to all of these situations. While the procedure should be used with caution in all scenarios, major river crossings should be evaluated carefully before implementing the RASP to ensure that the conservative nature of the evaluation is upheld. Future research could include evaluating the true impact

of overflow structures, potential turbulence caused by navigation, backwater effects of adjacent structures, and other factors typically associated with major rivers.

- Application to other areas
 - The RASP was prepared specifically for existing bridges in the state of Kansas. While the research performed in developing the RASP and the methodologies adopted for the different scour components were performed in other states, some calibration was done to fit detailed studies performed in this region. It is not known how applicable the procedure would be if performed in other regions with different geological and hydrological characteristics. Prior to applying the RASP to other regions research and testing should be performed.
- Rock scour
 - The rock scour procedure is highly qualitative in nature and relies heavily on either exposed rock formations or geotechnical advice. Much of the existing research found as part of this study with respect to rock scour depends on variables that are not easily obtained. Future research should be explored to obtain more information about potential solutions to rock scour.
- Bridge prioritization
 - The bridge prioritization method presented in this document utilizes the information we felt was readily available and accurate at the time. Although the prioritization developed as part of this study generally provided reasonable results, in applying this it was found that some bridges were excluded from

the initial prioritization group because of their age. Further research should be performed to incorporate a better means of placing a value on community importance and the size of the river being crossed.

- Methods of structural evaluation
 - Structures that are not on shallow rock foundations, but on a piling group, must have a structural evaluation after applying the RASP. This is to ensure that structural integrity is maintained with the assessed scour depth. Further research should be performed to provide an efficient means of determining the structural integrity of typical bridge configurations without having to calculate values every time.
- Statistical analysis
 - This procedure requires the compilation of a tremendous amount of data on each structure. This data could be analyzed in an effort to determine if there are any particular characteristics that have statistical significance with respect to potential scour issues.

Works Cited

- Annandale, G. W., R. J. Wittler, J. F. Ruff, and T. M. Lewis. "Prototype Validation of Erodibility index for Scour in Fractured Rock Media." *1998 ASCE International Water Resources Engineering Conference*. Memphis, Tenn, 1998. 1096-1101.
- Bradley, J. B., D. L. Richards, and C. D. Bahner. *HEC-9: Debris Control Structures - Evaluation and Countermeasures, Third Ed.* Washington, D.C.: FHW-IF-04-016, Federal Highway Administration, U.S. Department of Transportation, 2005.
- Federal Interagency Stream Restoration Work Group. "Stream Corridor Restoration: Principles, Processes, and Practices." United States Department of Agriculture, Natural Resources Conservation Service, 1998.
- Holnbeck, S. R., and C. Parrett. "Method for Rapid Estimation of Scour at Highway Bridges Based on Limited Site Data." Water-Resources Investigations Report 96-4310, United State Department of the Interior, United States Geological Survey, 1997.
- Hopkins, T. C., and T. L. Beckham. *Correlation of Rock Quality Designation and Rock Scour Around Bridge Piers and Abutments Founded on Rock*. Research Report, Lexington: Kentucky Transportation Center, 1999, 31.
- Junke, G., K. Kerenyi, and J. Pagan-Ortiz. *Bridge Pressure Flow Scour for Clear Water Conditions*. Laboratory Report, U.S. Department of Transportation, Federal Highway Administration, Springfield: National Technical Information Service, 2009, 48.
- Kansas Department of Transportation. *Bridge Inspection Manual - NBIS Condition Ratings*. Topeka, Kansas: Bureau of Local Projects, Bridge Management Section, 2012.
- Lagasse, P. F.; Clopper, P. E.; Pagan-Ortiz, J. E.; Zevenbergen, L. W.; Arneson, L. A.; Schall, J. D.; Girard, L. G. *Bridge Scour and Stream Instability Countermeasures*. Hydraulic Engineering Circular 23, Department of Transportation, National Highway Institute, Washington, D.C.: Federal Highway Administration, 2009.
- Lagasse, P. F., J. D. Schall, and E. V. Richardson. *Stream Stability at Highway Structures, 3rd Edition*. Hydraulic Engineering Circular 20, Department of Transportation, National Highway Institute, Washington, D.C.: Federal Highway Administration, 2001.
- Lwin, M. M. "Unknown Foundations." *FHWA*. October 29, 2009. <http://www.fhwa.dot.gov/unknownfoundations/091029.cfm> (accessed June 15, 2010).

Lyn, D.A. *Pressure Flow Scour: A Re-Examination of the HEC-18 equation*. Study, School of Civil Engineering, Purdue University, W. Lafayette: American Society of Civil Engineers, 2006.

Richardson, E. V., and S. R. Davis. *Evaluating Scour at Bridges, 4th Edition*. Hydraulic Engineering Circular 18, Department of Transportation, National Highway Institute, Washington, D.C.: Federal Highway Administration, 2001.

Vita

Aaron Dwight Moore was born October 23rd 1977 in Victorville, California while his father served in the Air Force. He attended Davis County High School in Bloomfield, Iowa where he played multiple sports and participated in the Future Farmers of America (FFA). He then attended Indian Hills Community College where he graduated in 1998 earning an Associate of Applied Science degree in Machine Technology. Aaron then went on to work at various jobs before returning to pursue a Bachelor of Science degree. After beginning the degree program at the University of Missouri-Kansas City, Aaron chose to pursue Civil Engineering as the degree to obtain and graduated in 2009. He married in 2003 and has three children. Aaron currently works at TranSystems Corporation in Kansas City, Missouri.

Appendix A

Procedural Flow Chart

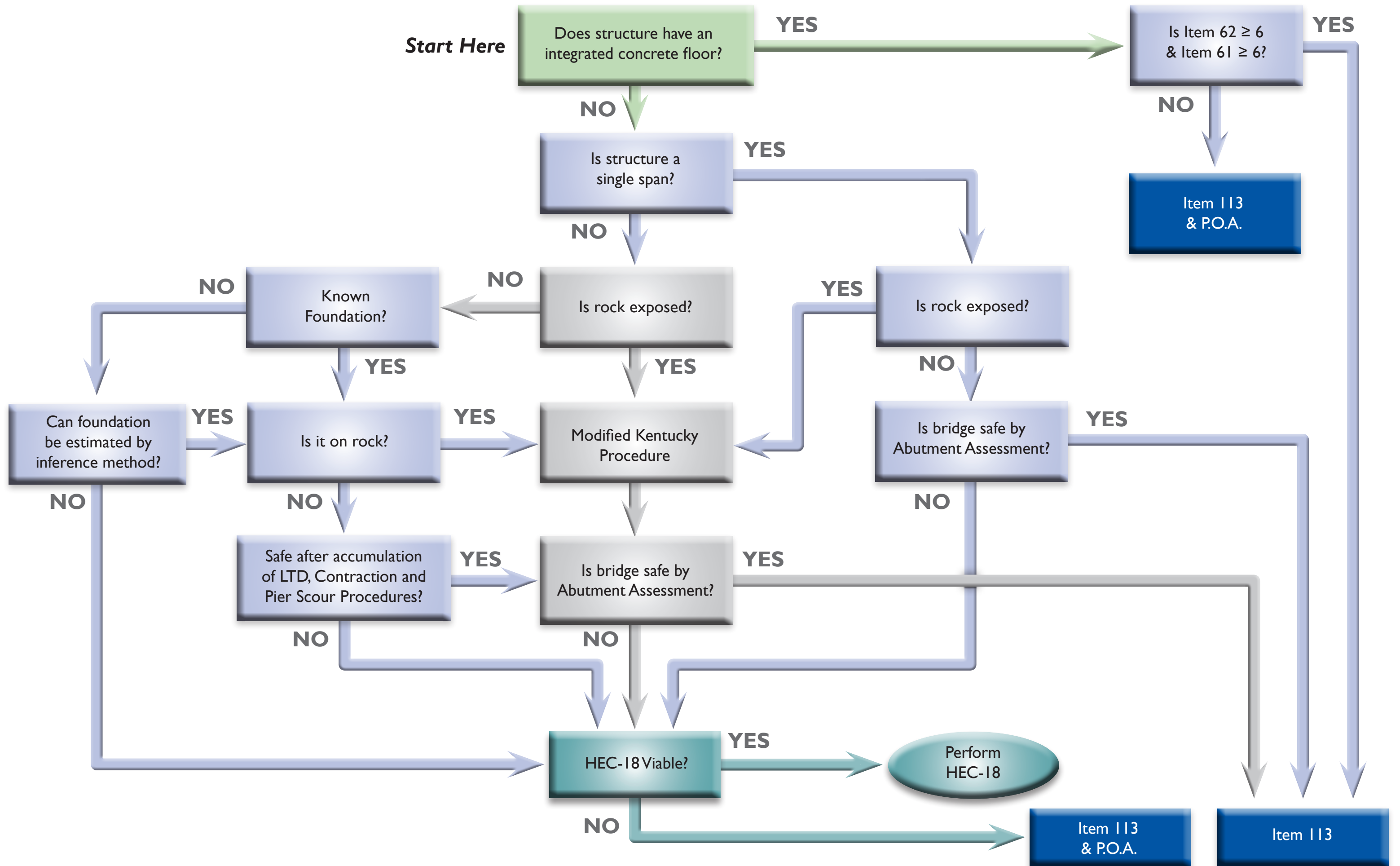

Appendix B

Study Area Map

Rapid Assessment for Scour Procedure

 Counties Assessed

Nebraska

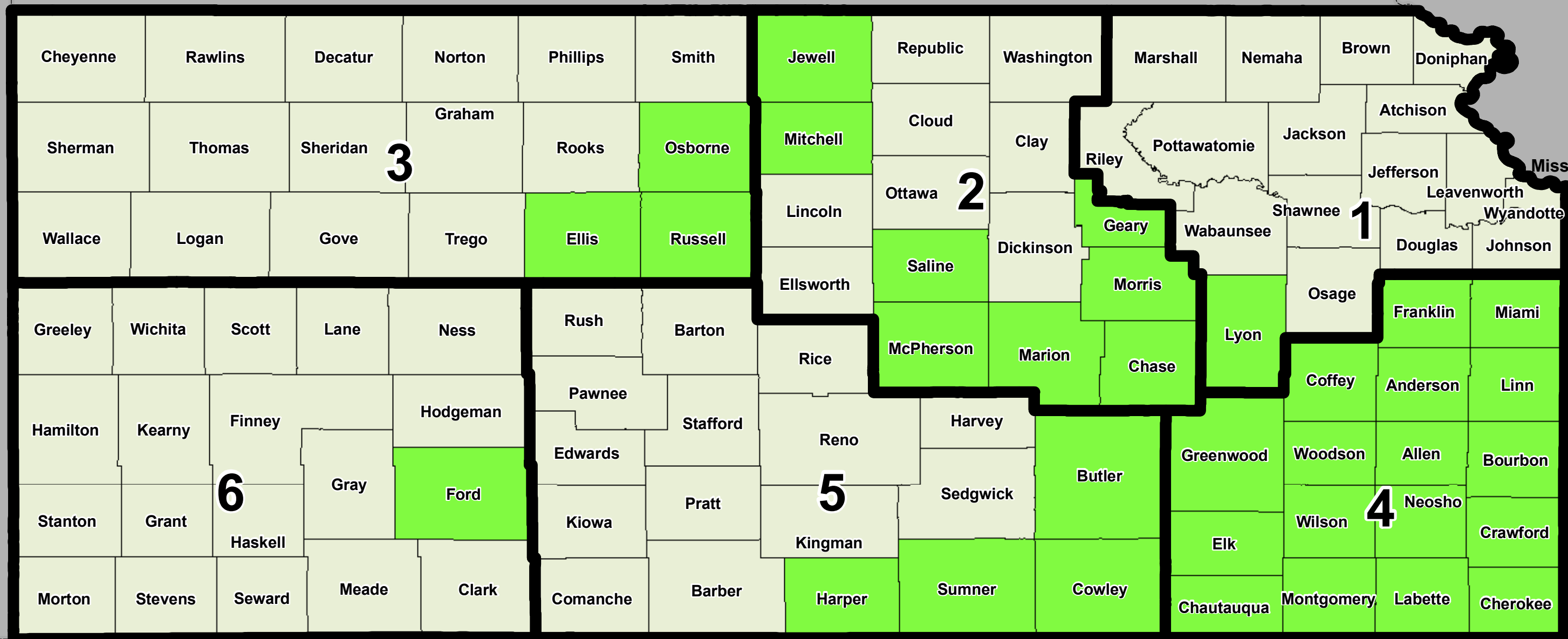

Missouri

Oklahoma

Texas

Arkansas

Appendix C

NBIS Item 113 Coding Maps

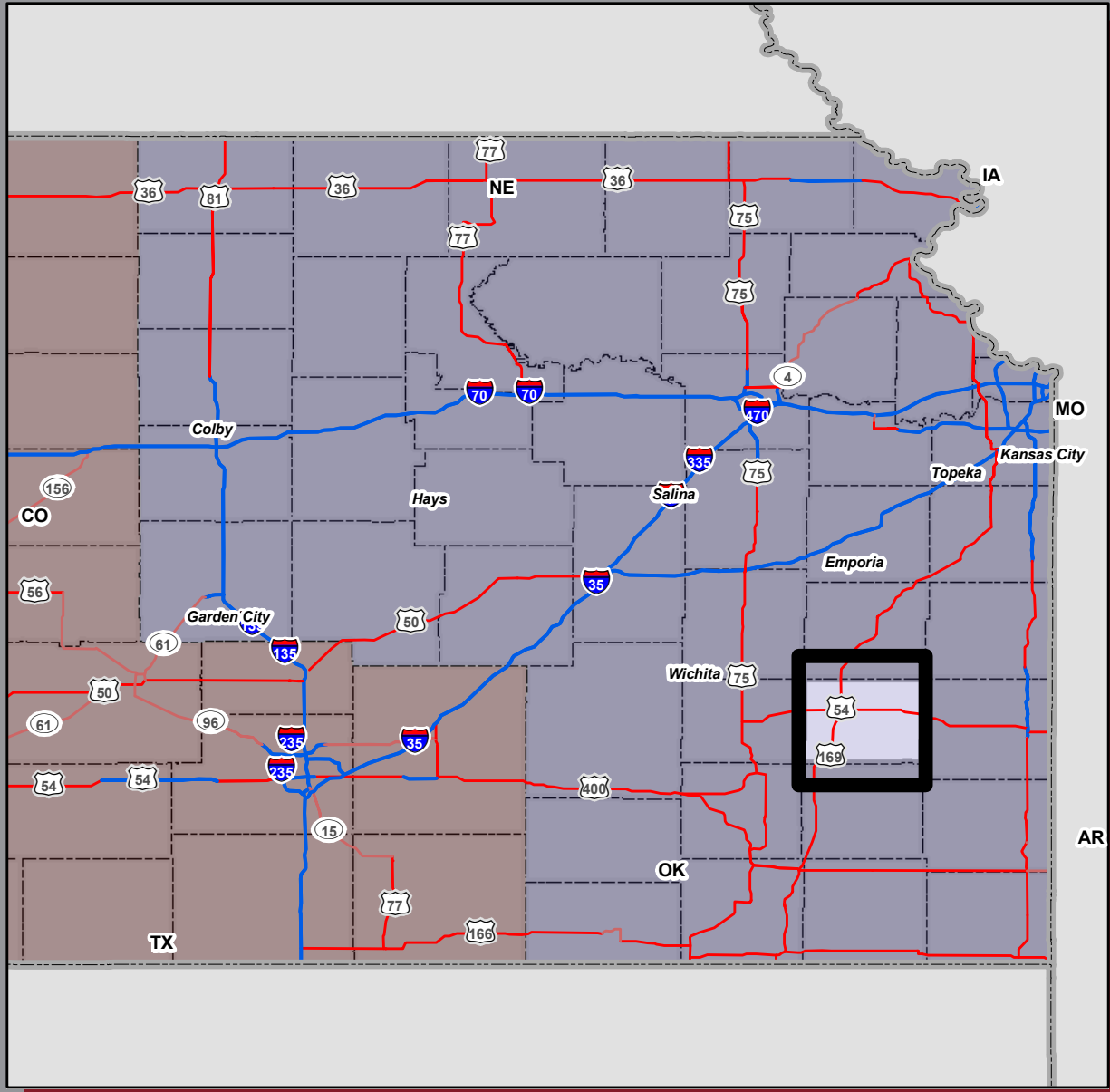
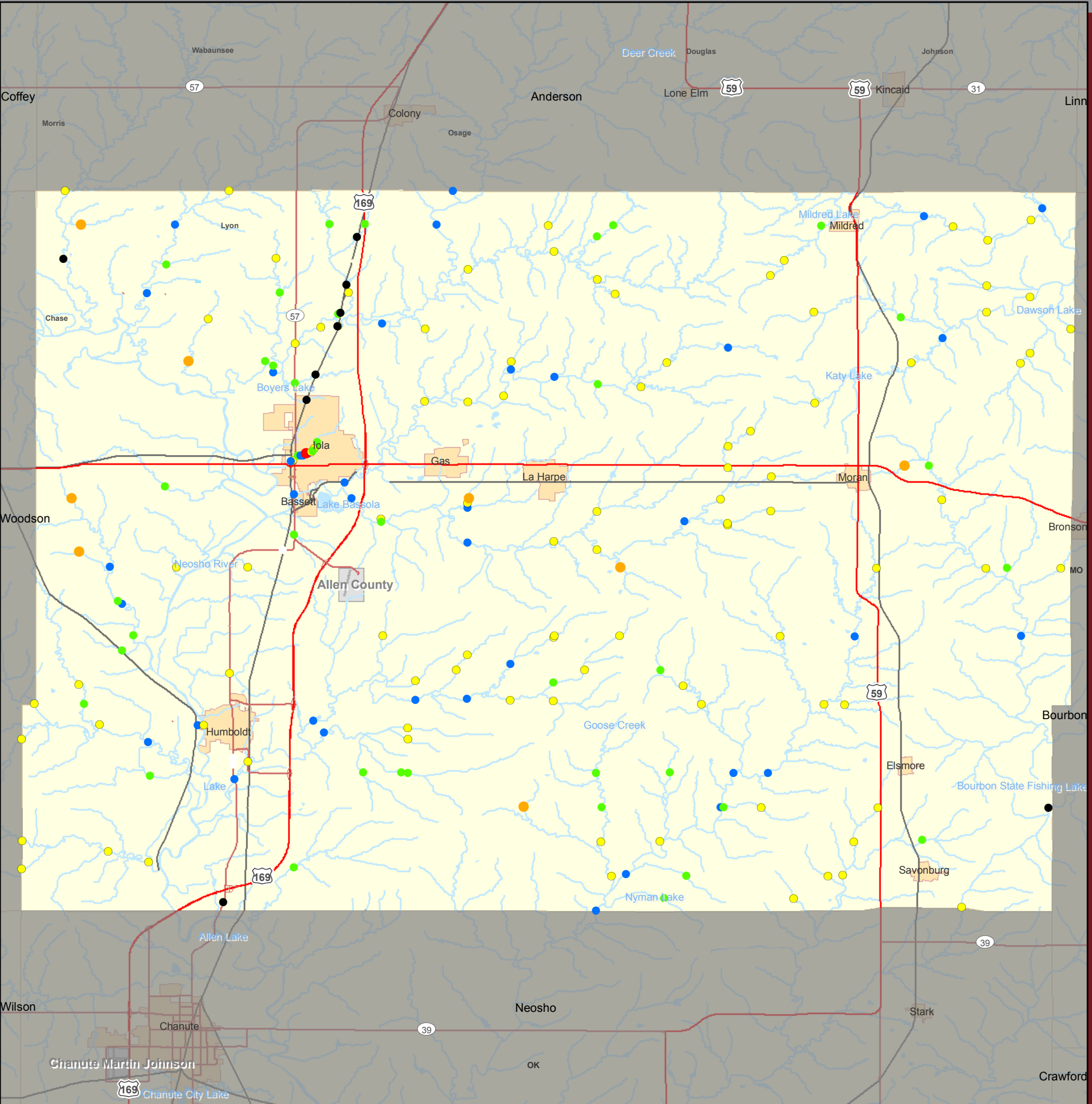

Allen County Item 113 Coding

● 2	— Interstate
● 3	— US and State Highways
● 4	— Secondary State and County
● 5	— Local or rural road
● 8	— Railroads
N	
● U	



KDOT Scour Analysis
Item 113 Codes

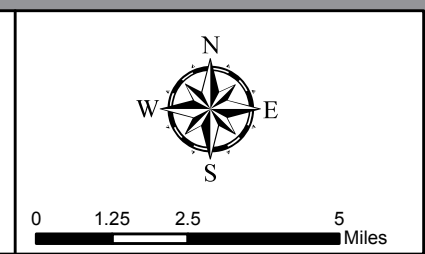

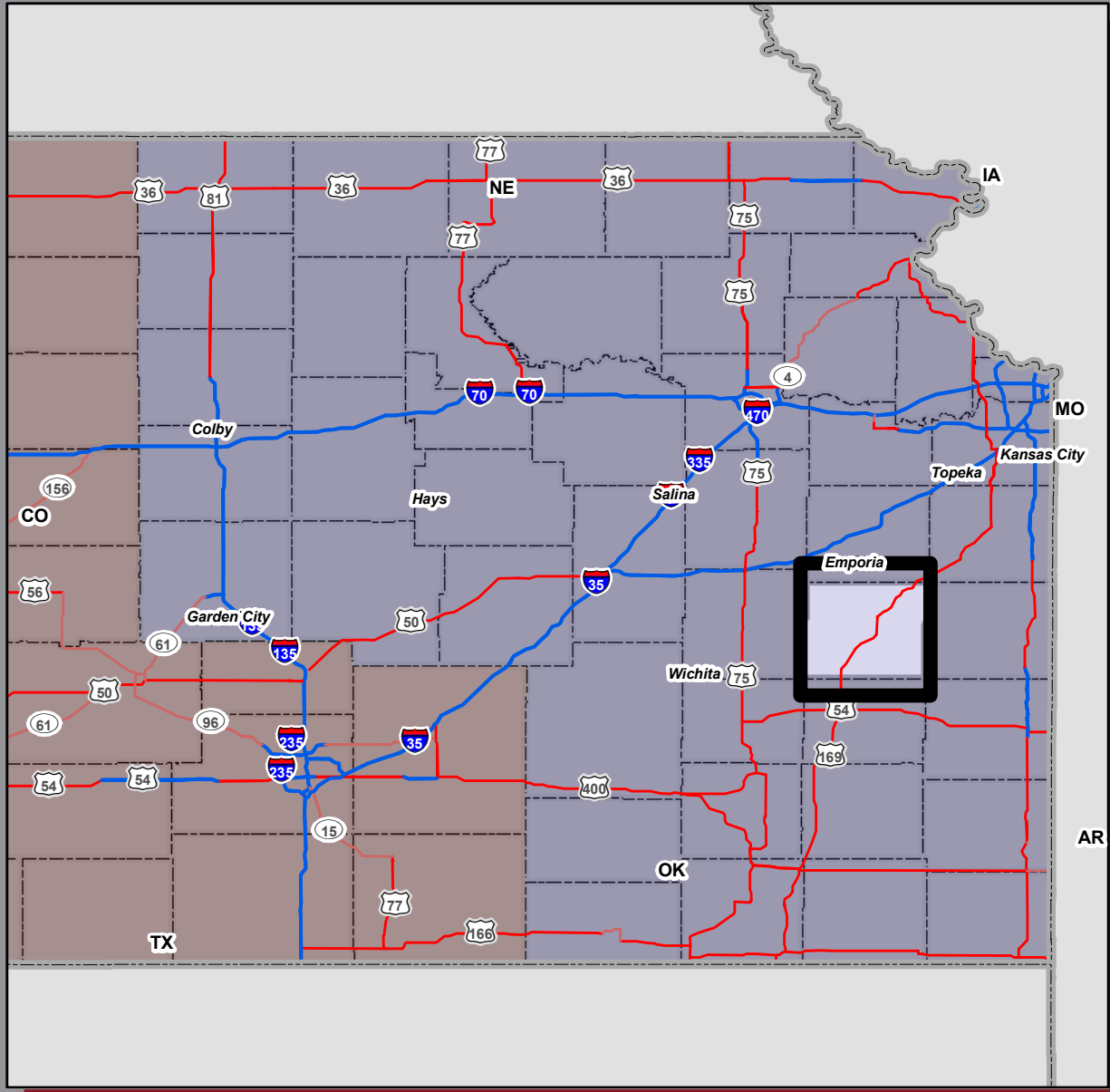
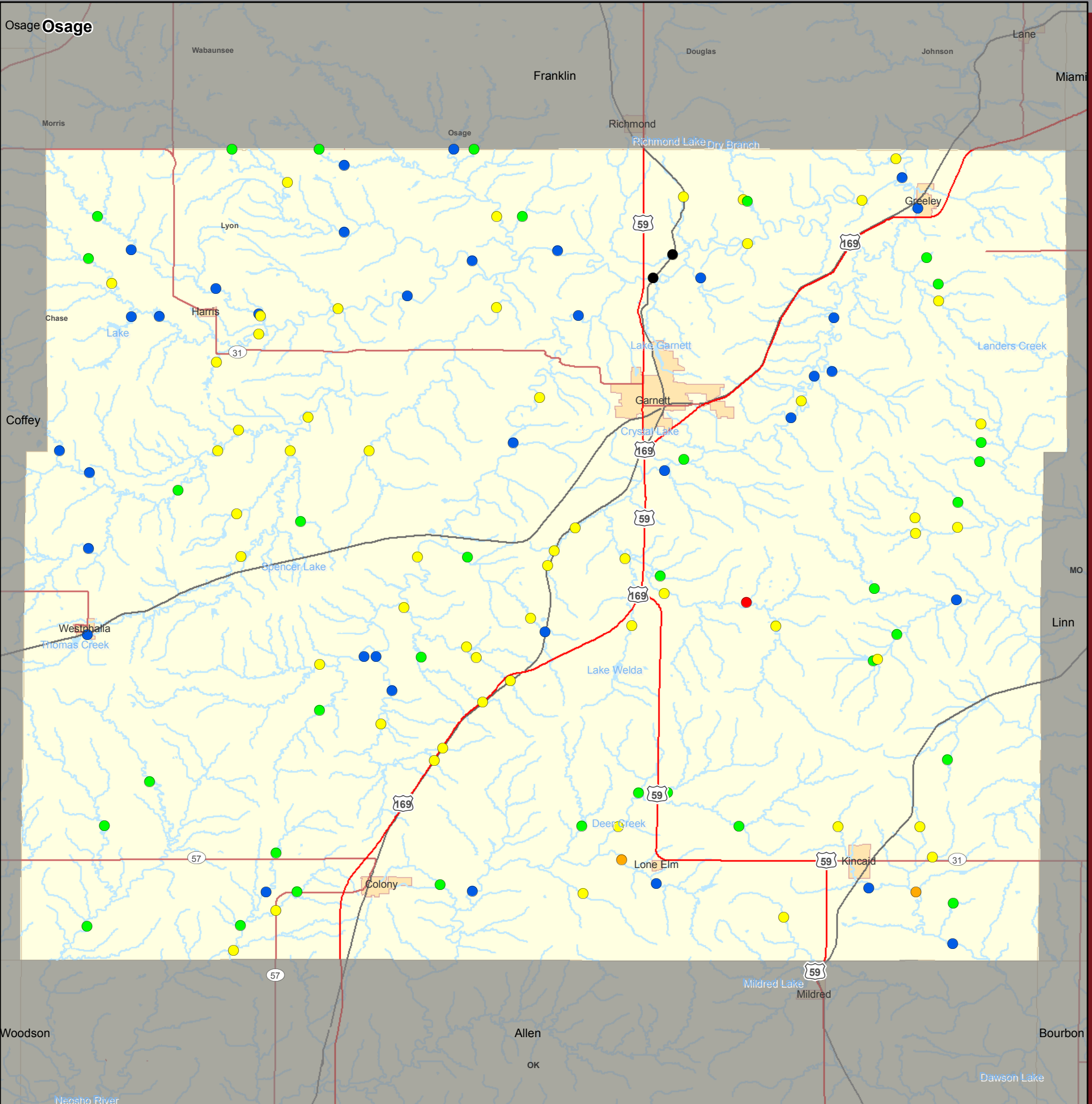

Anderson County Item 113 Coding

● 2	● 3	● 4	● 5	● 8	○ N	● U	— Interstate
							— US and State Highways
							— Secondary State and County
							— Local or rural road
							+++++ Railroads

KDOT Scour Analysis
Item 113 Codes

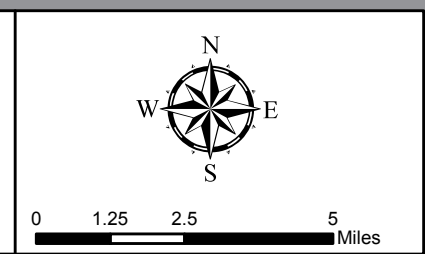

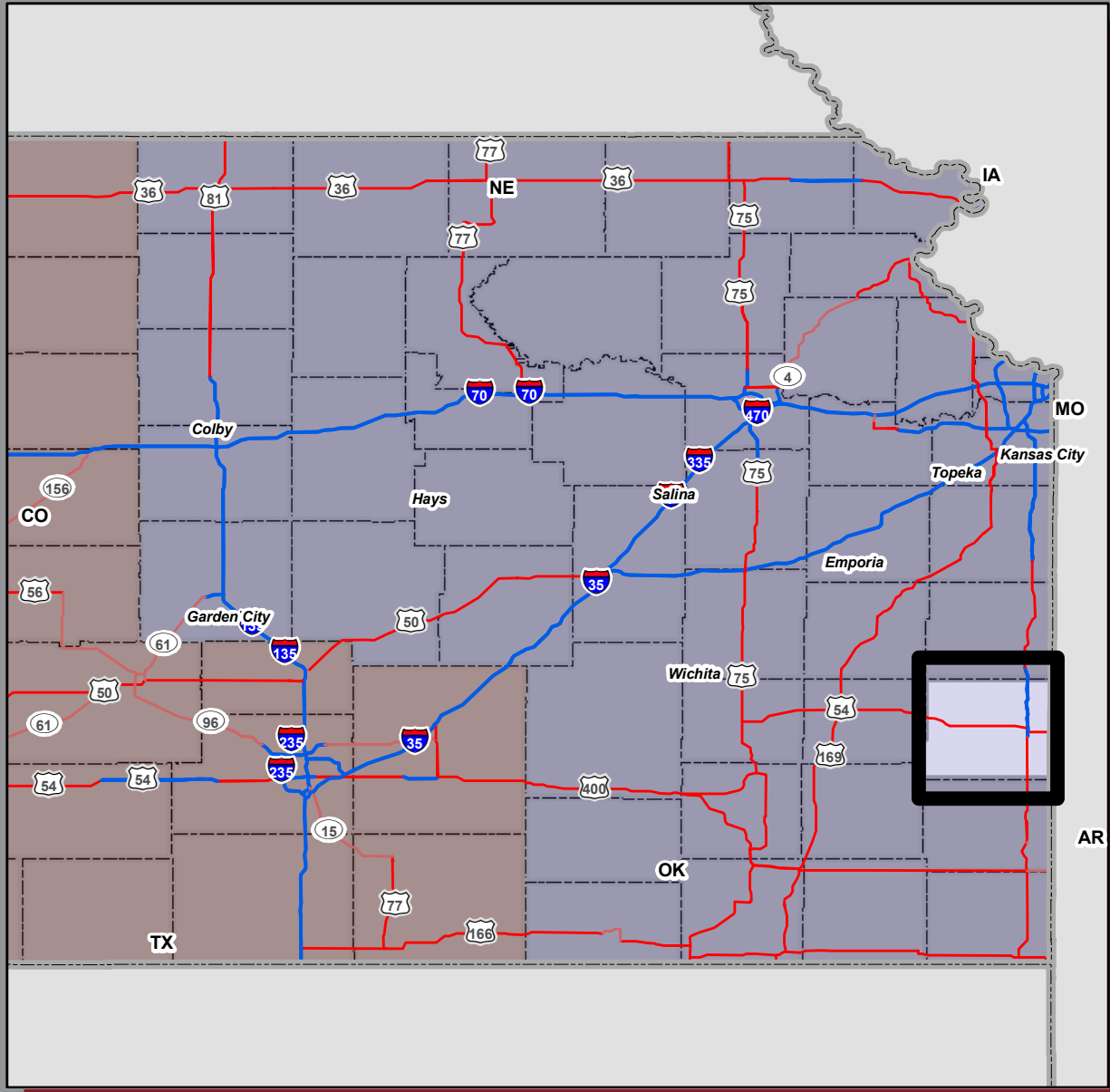
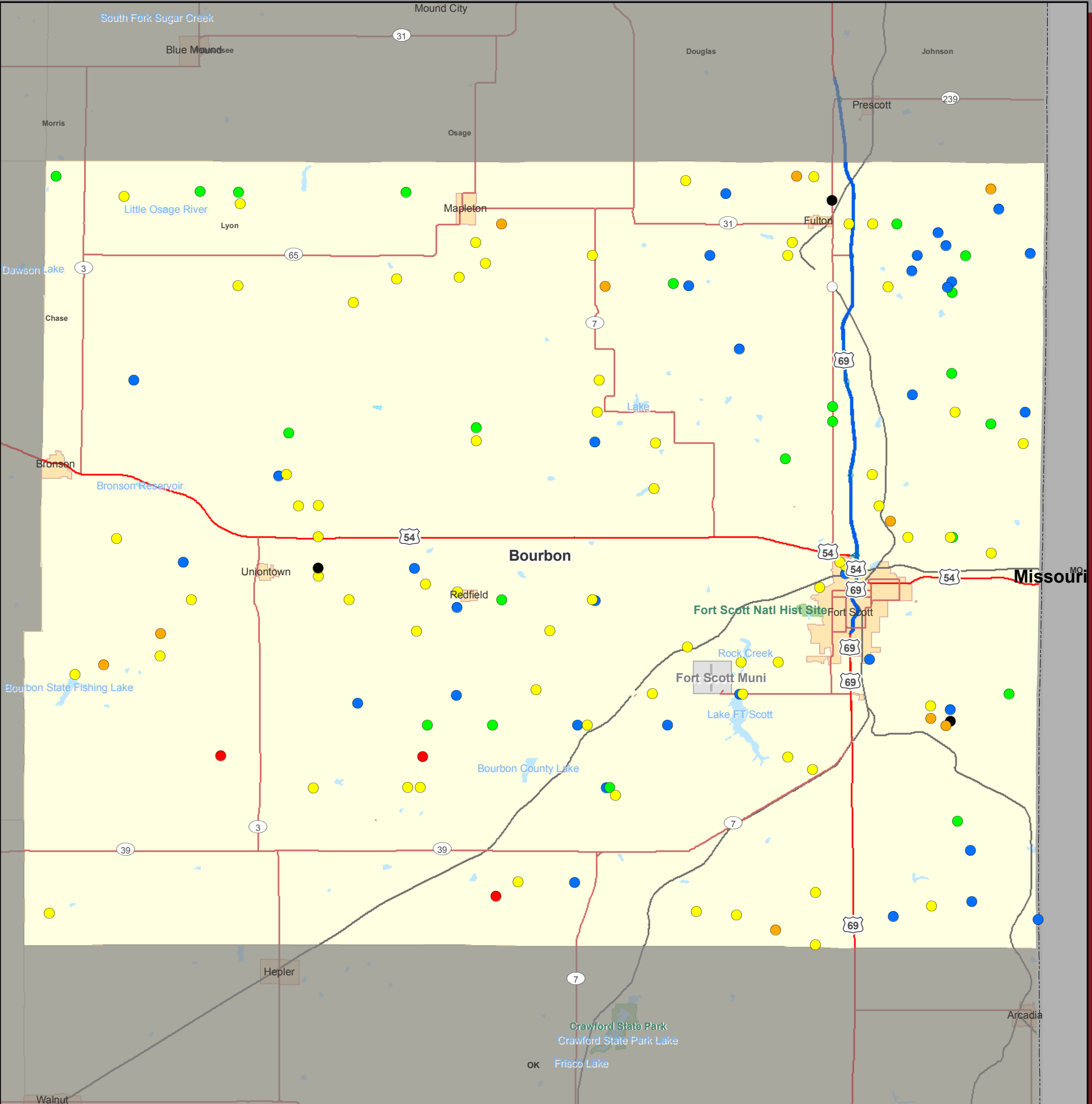

**Bourbon County Kansas
Item 113 Coding**

● 2	— Interstate
● 3	— US and State Highways
● 4	— Secondary State and County
● 5	— Local or rural road
● 8	— Railroads
○ N	
● U	

KDOT Scour Analysis
Item 113 Codes

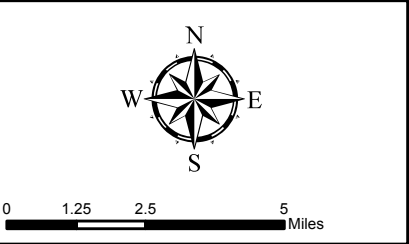

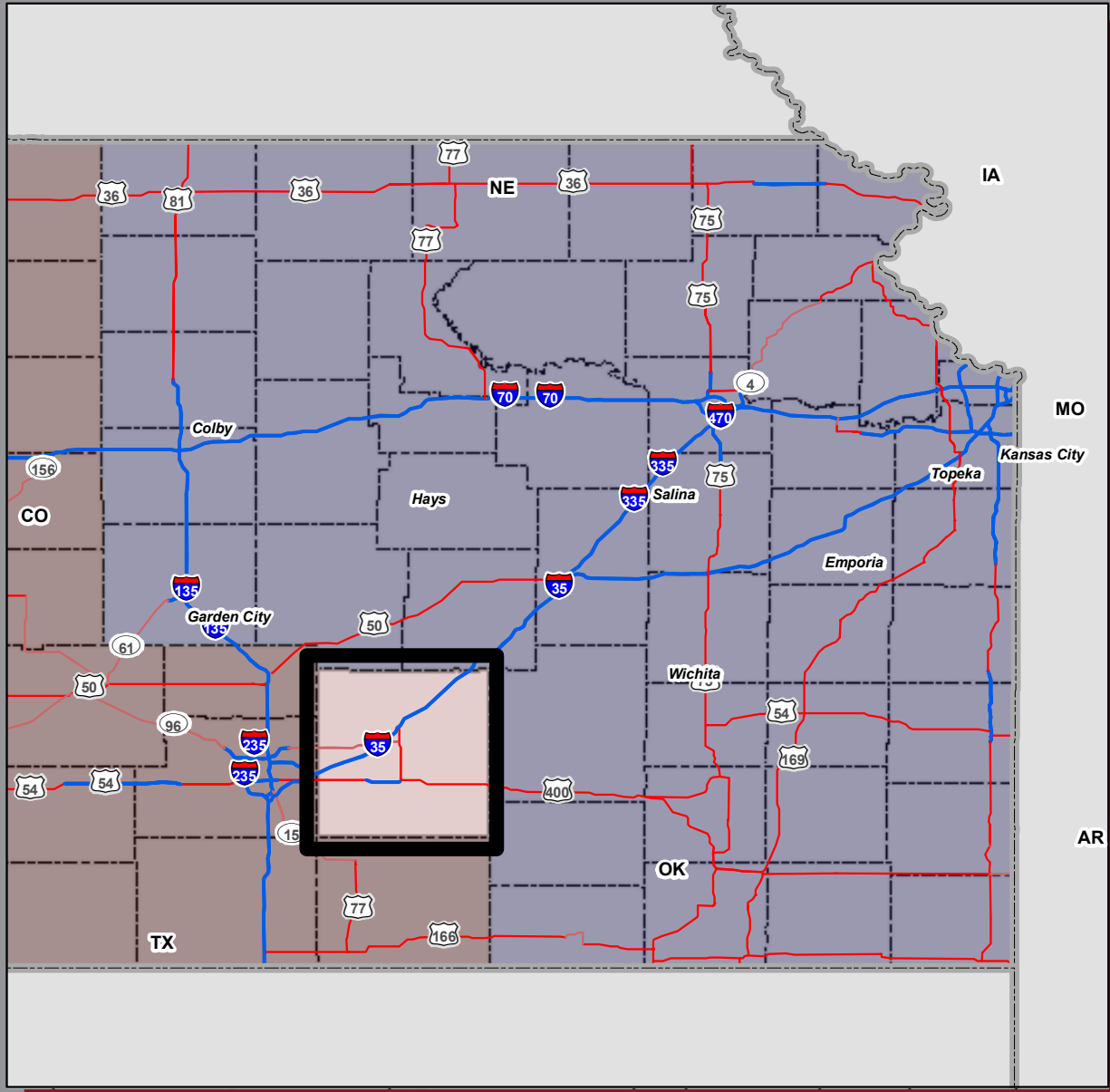
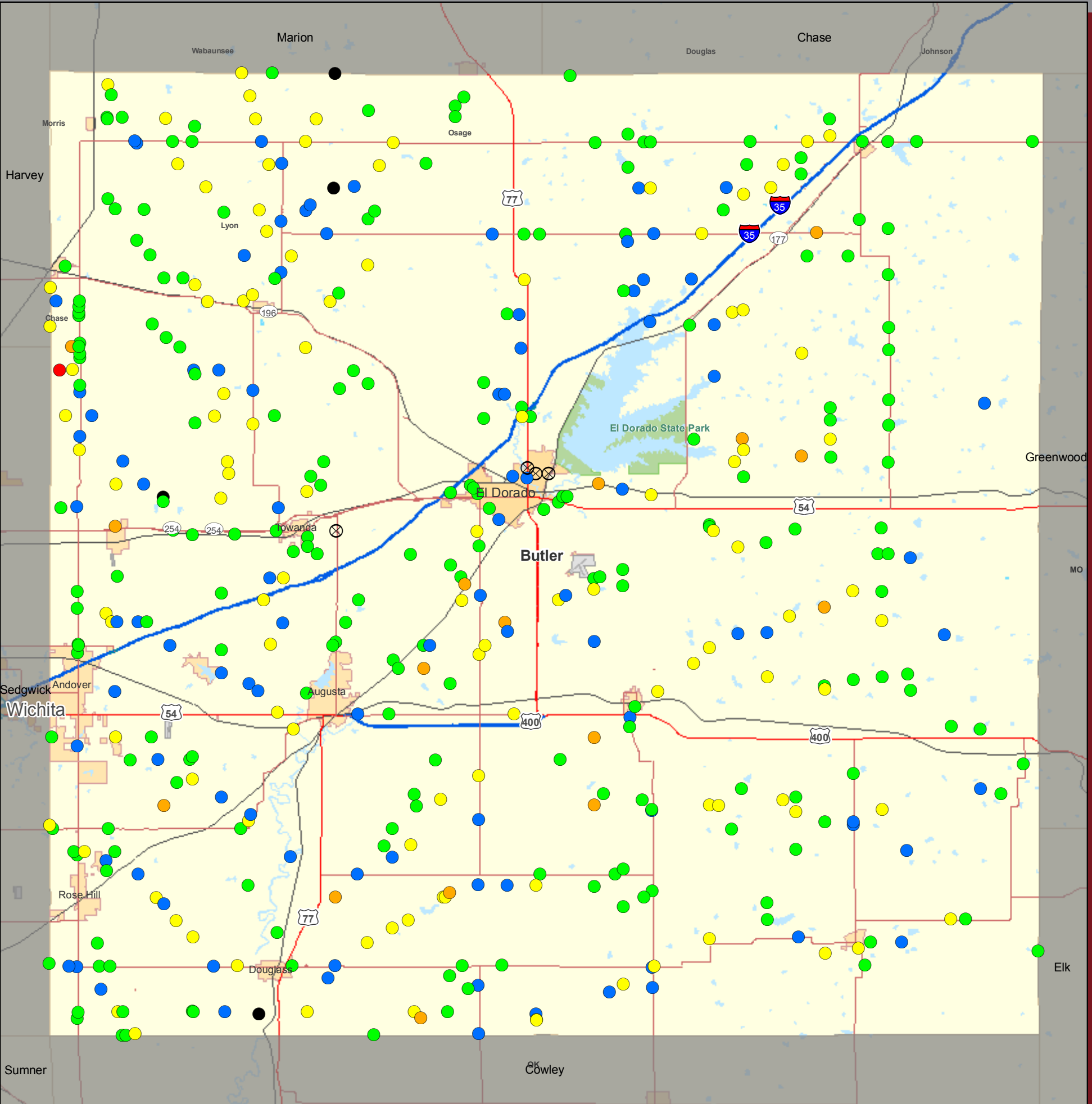

Butler County Item 113 Coding

●	Interstate
●	US and State Highways
●	Secondary State and County
●	Local or rural road
●	Railroads
⊗	
●	



KDOT Scour Analysis
Item 113 Codes

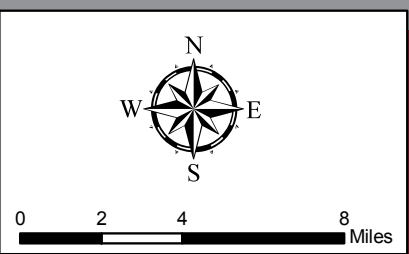

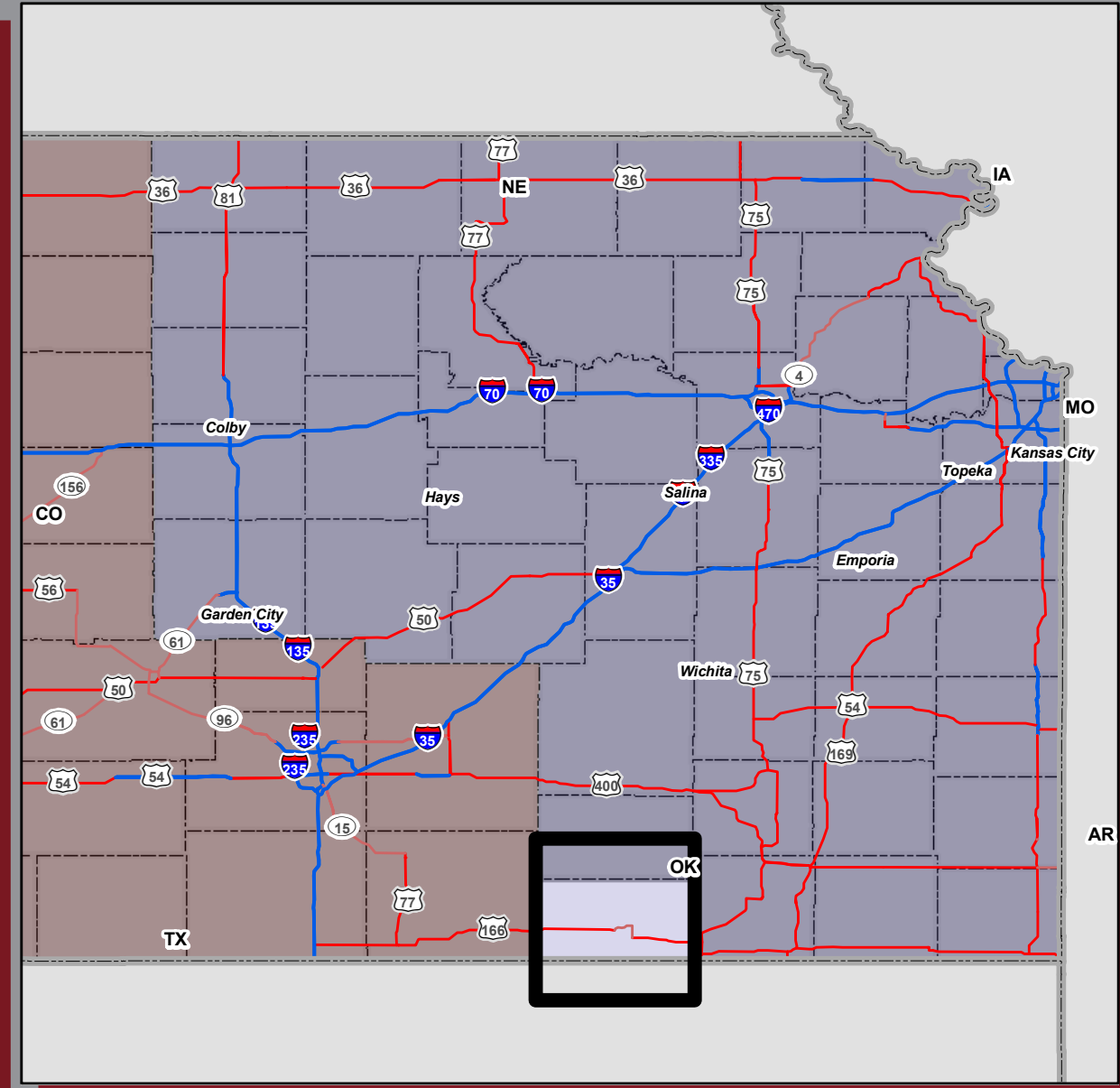
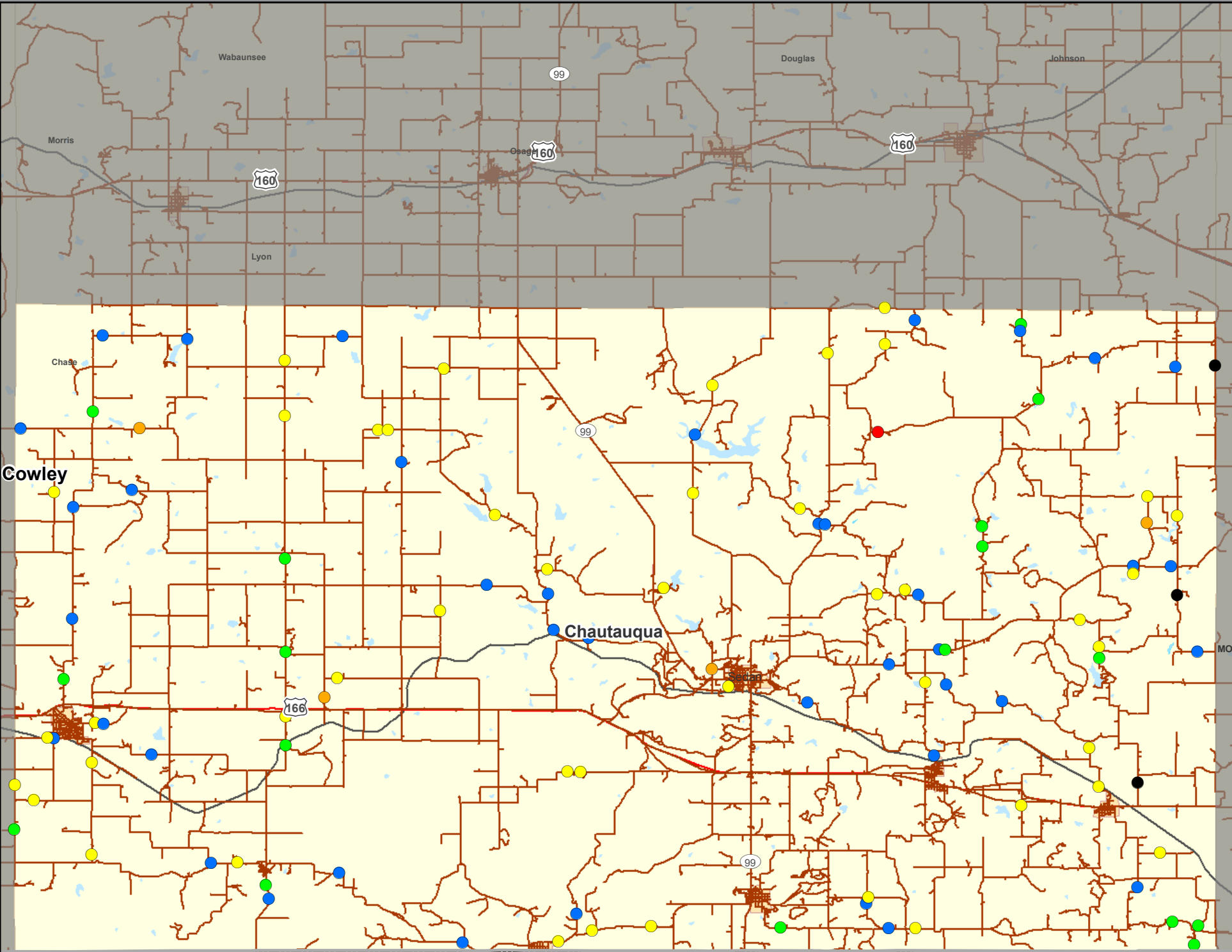

**Chautauqua County Kansas
Item 113 Coding**

- 2
- 3
- 4
- 5
- 8
- U

- Interstate
- US and State Highways
- Secondary State and County
- Local or rural road
- +++++ Railroads



KDOT Scour Analysis
Item 113 Codes

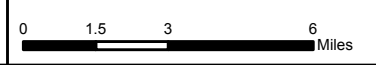

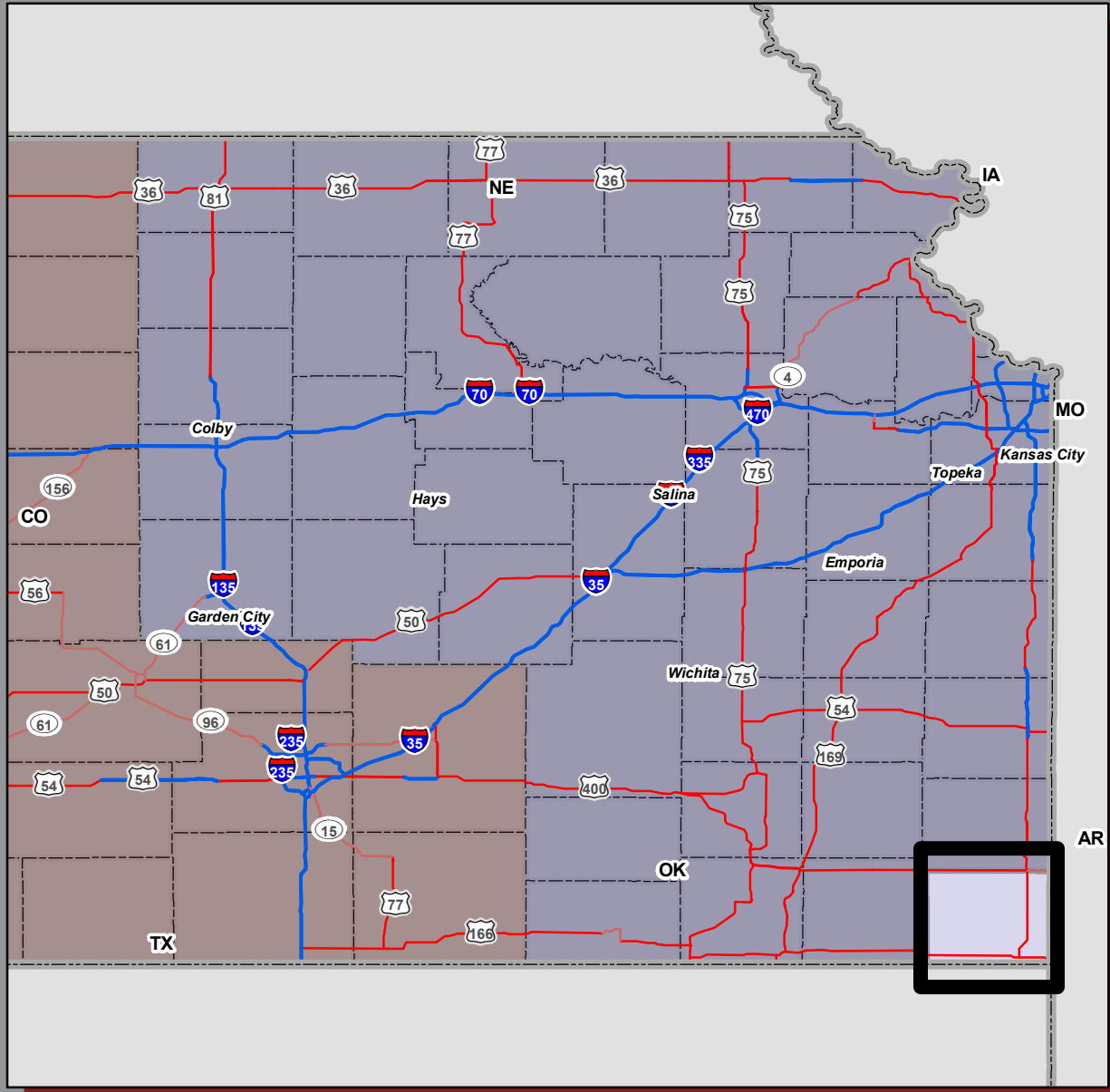
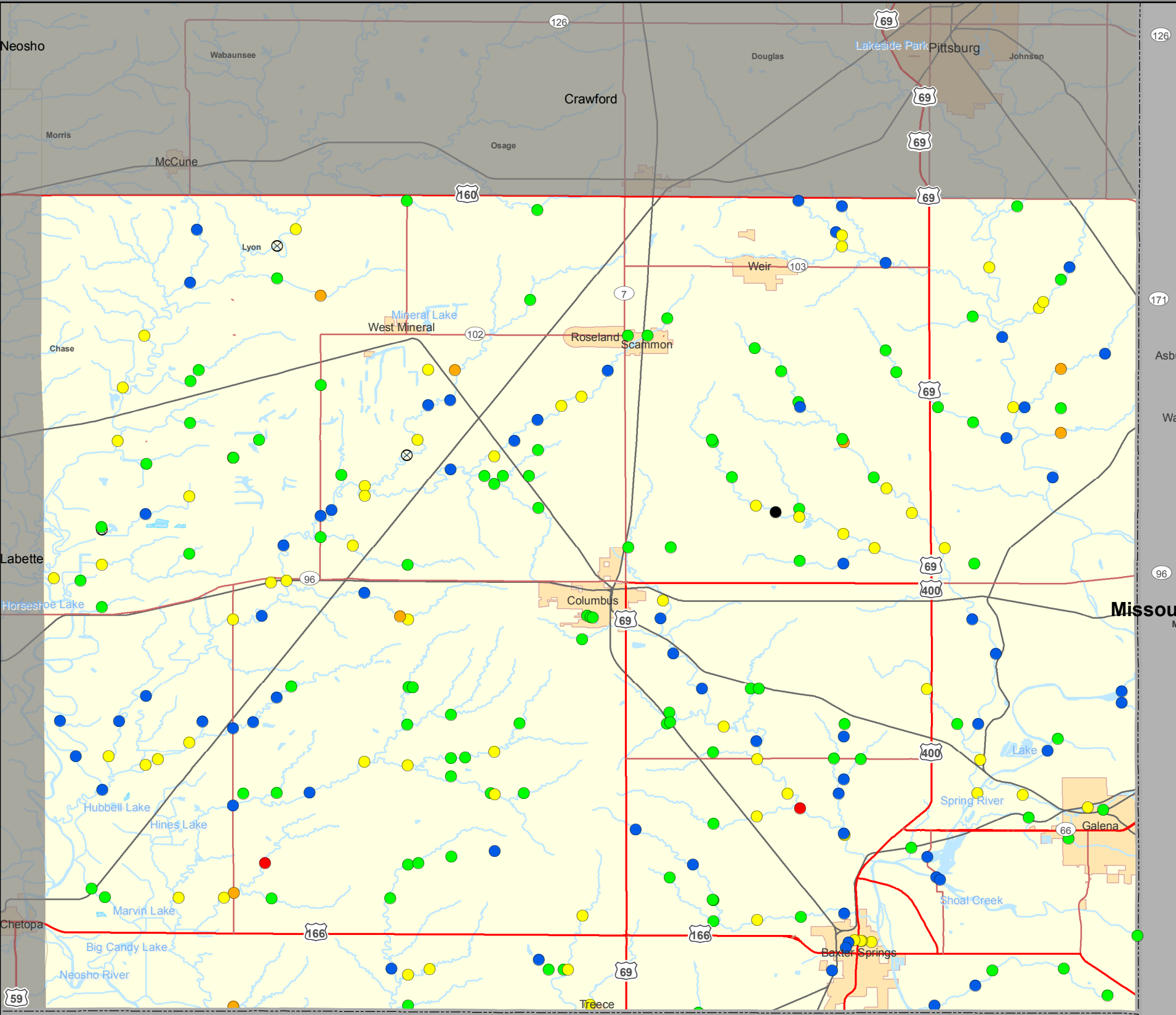

Item 113 Coding

⊗ 0	— Interstate
● 2	— US and State Highways
● 3	— Secondary State and County
● 4	— Local or rural road
● 5	— Railroads
● 8	
● U	



KDOT Scour Analysis
Item 113 Codes

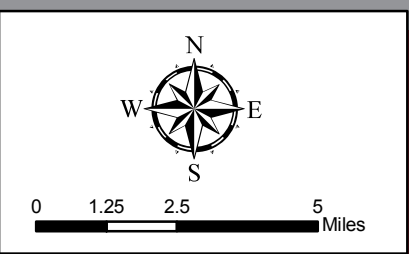

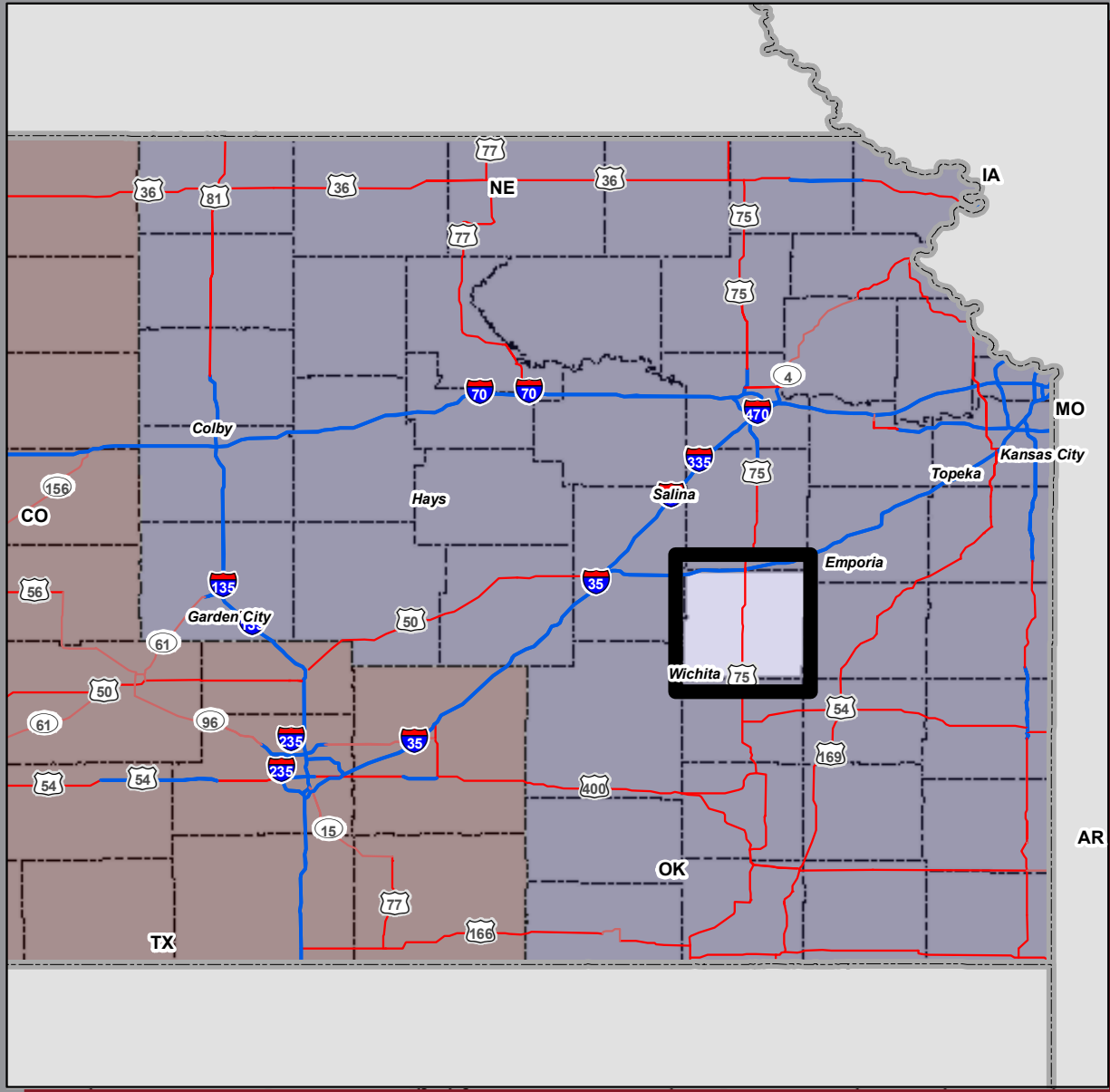
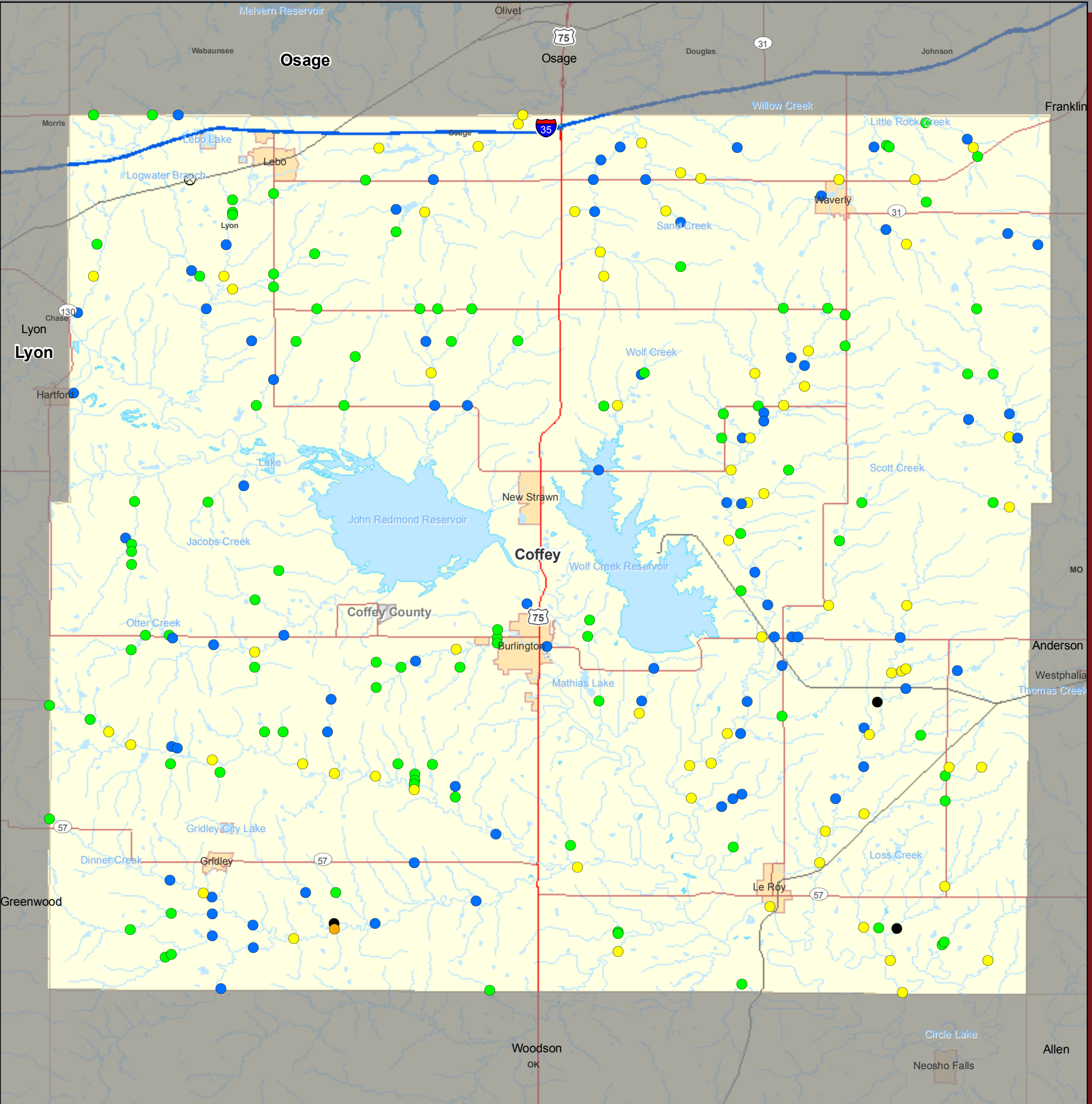

Item 113 Code

- 3
- 4
- 5
- 8
- ⊗ N
- U

Legend:

- Interstate
- US and State Highways
- Secondary State and County
- Local or rural road
- +++++ Railroads



KDOT Scour Analysis
Item 113 Codes

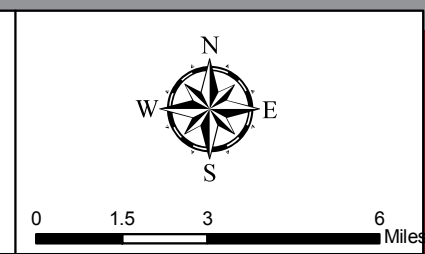

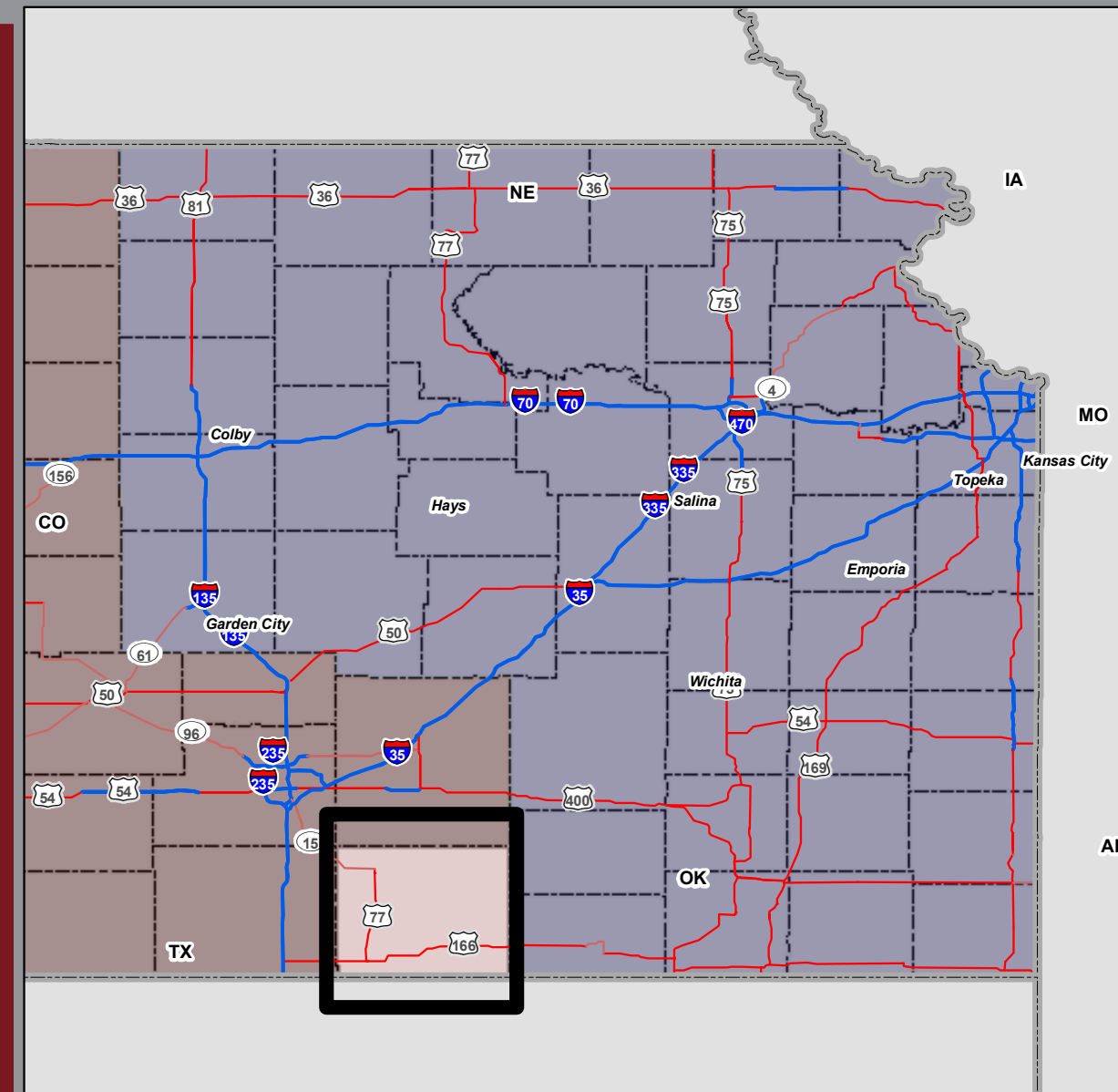
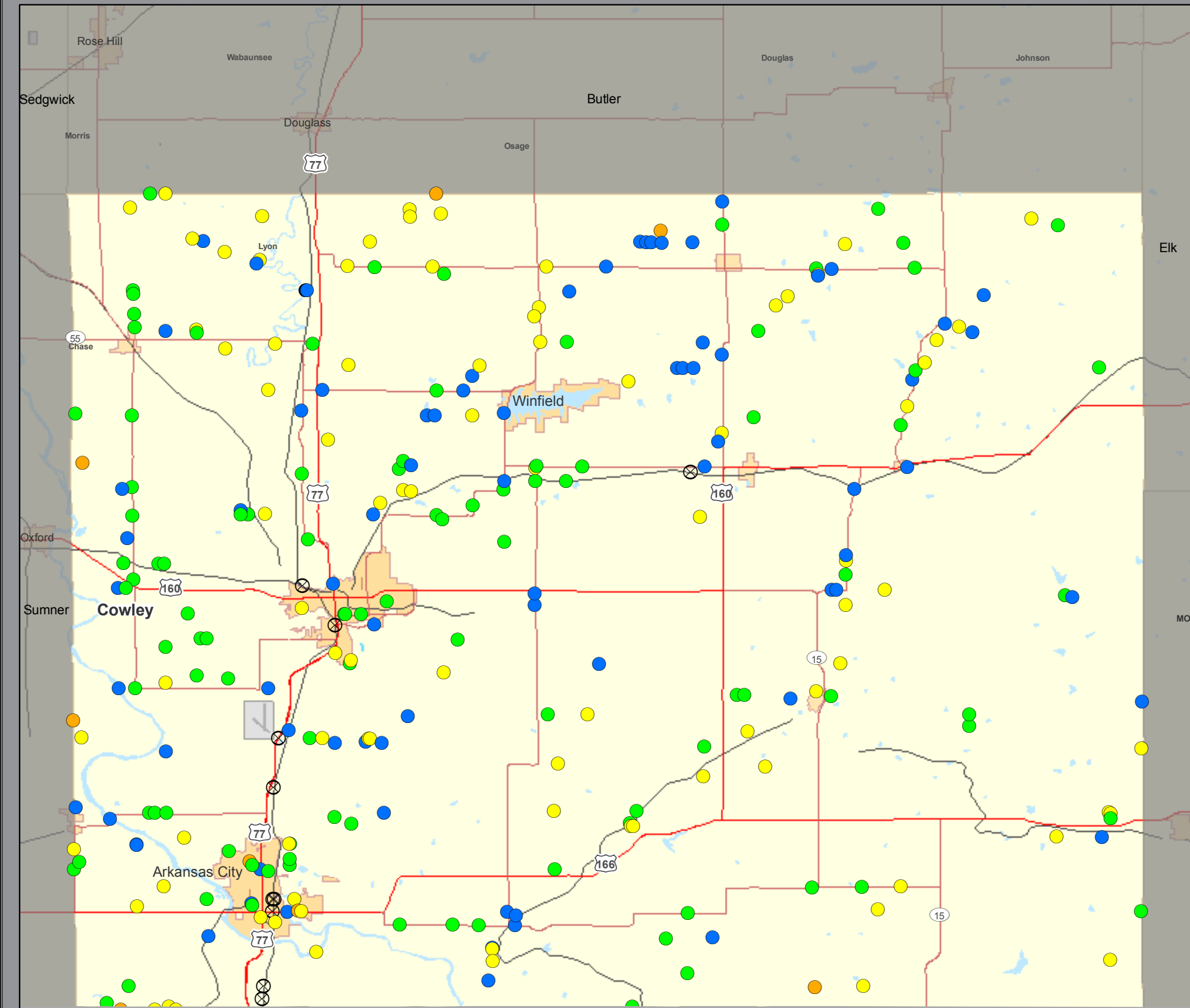

Cowley County Item 113 Coding

- | | |
|-----|------------------------------|
| ● 3 | — Interstate |
| ● 4 | — US and State Highways |
| ● 5 | — Secondary State and County |
| ● 8 | — Local or rural road |
| ⊗ N | — Railroads |
| ● U | |



KDOT Scour Analysis
Item 113 Codes

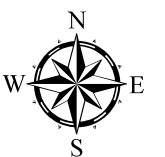

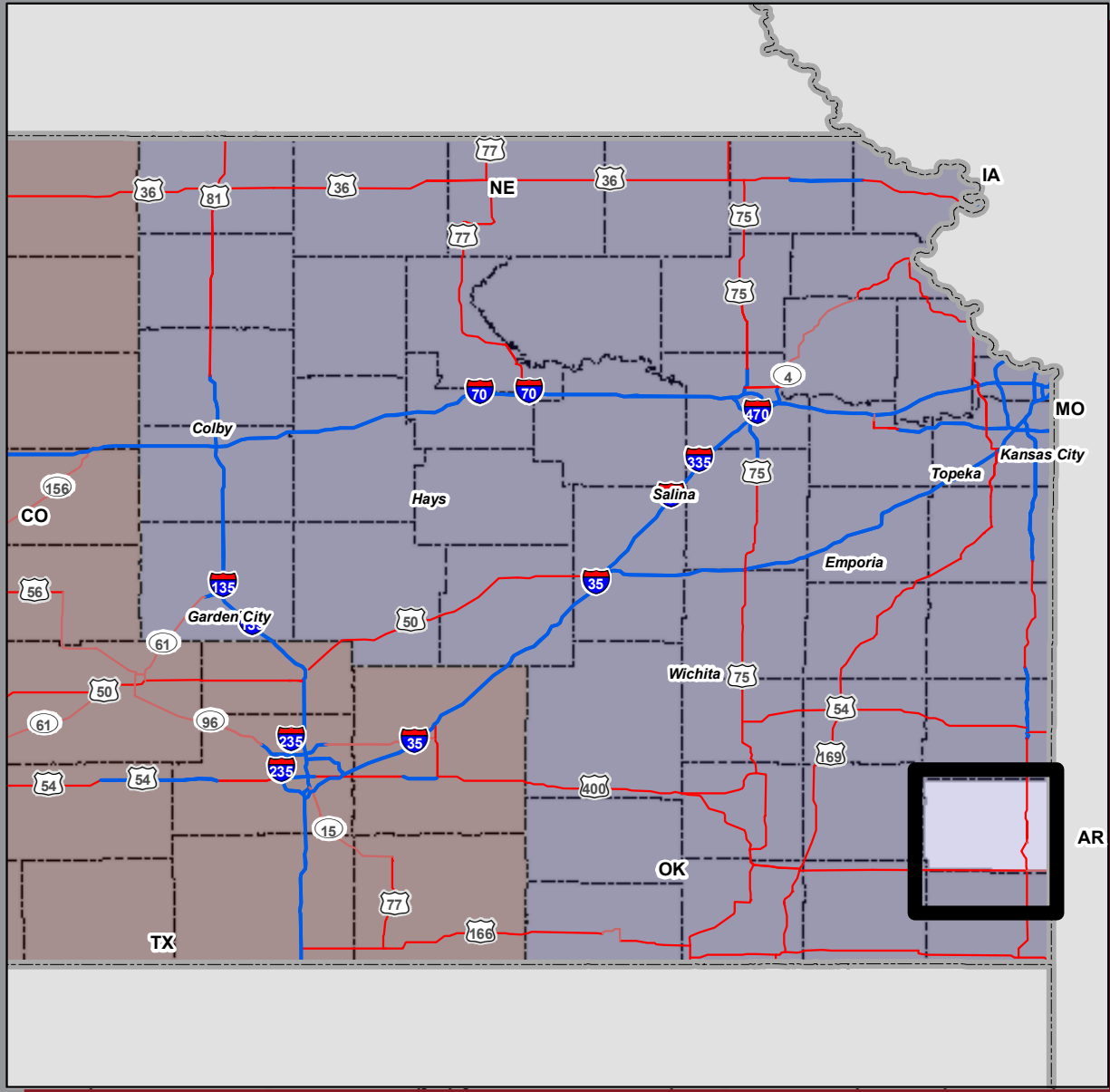
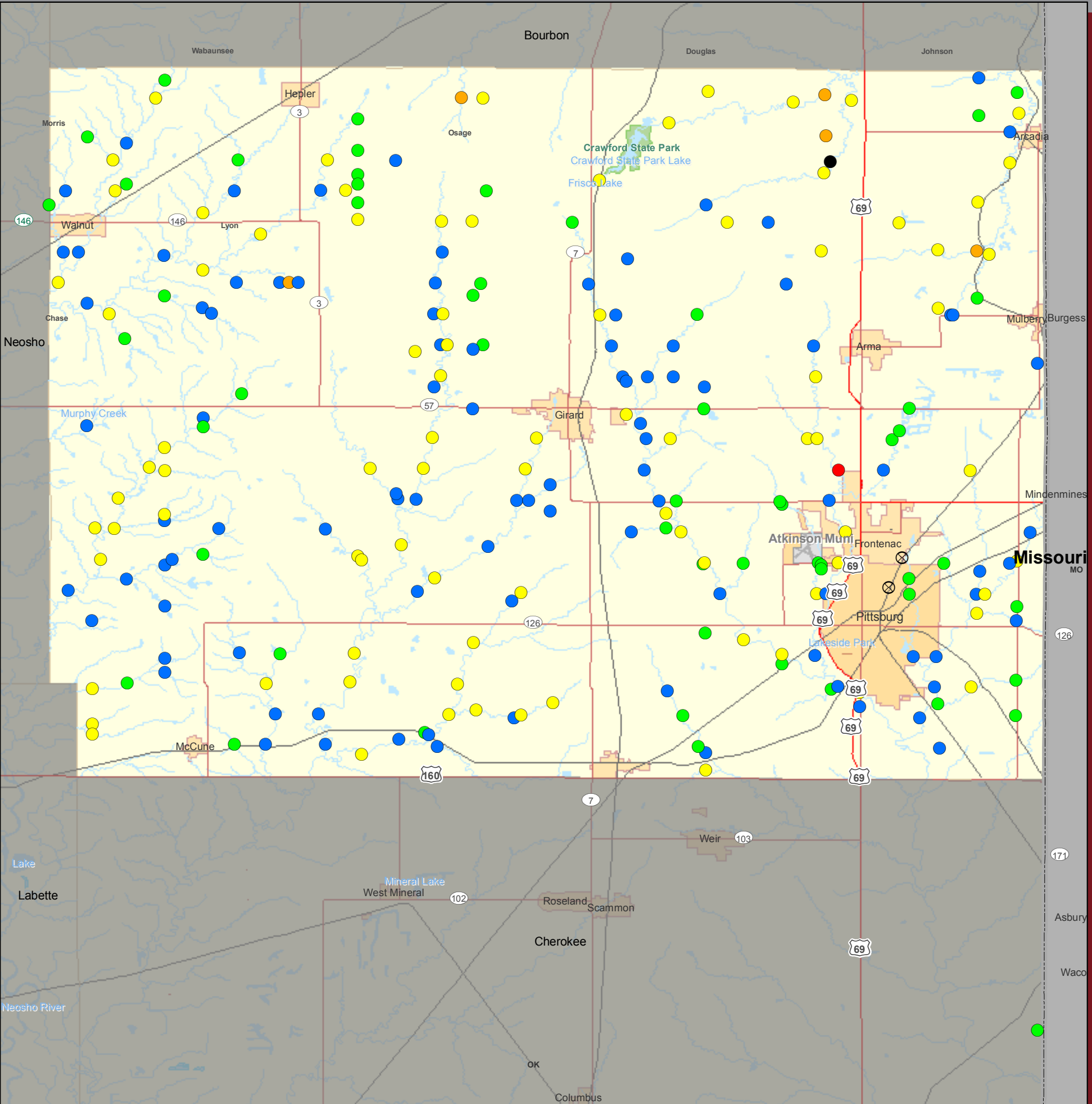

Item 113 Coding

- 2
- 3
- 4
- 5
- 8
- ⊗ N
- U

- Interstate
- US and State Highways
- Secondary State and County
- Local or rural road
- +++++ Railroads



KDOT Scour Analysis
Item 113 Codes

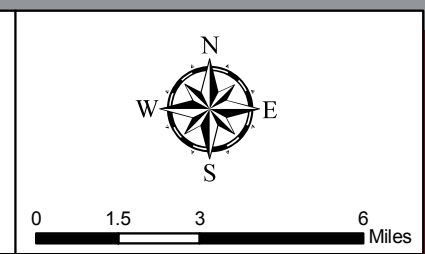

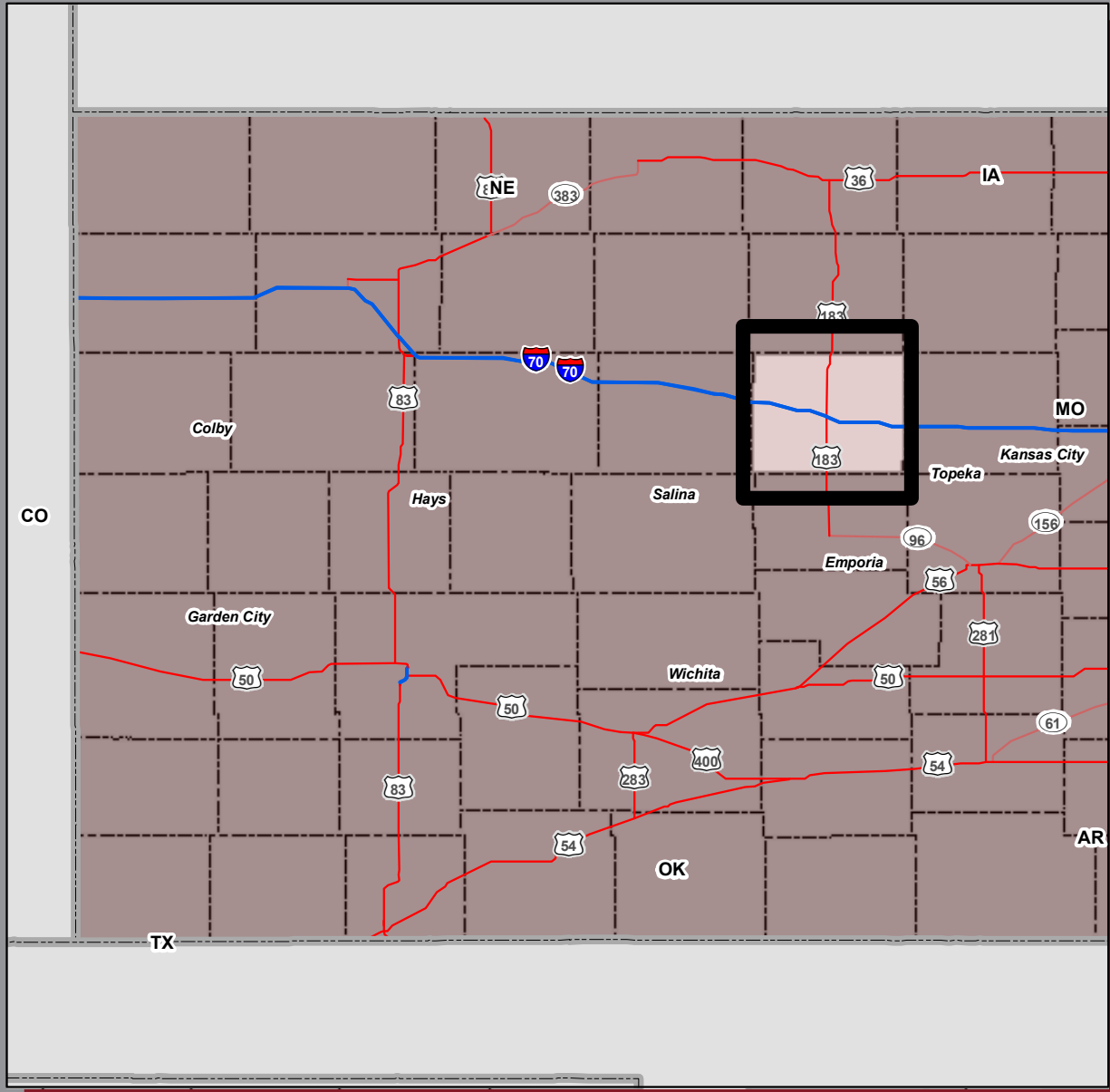
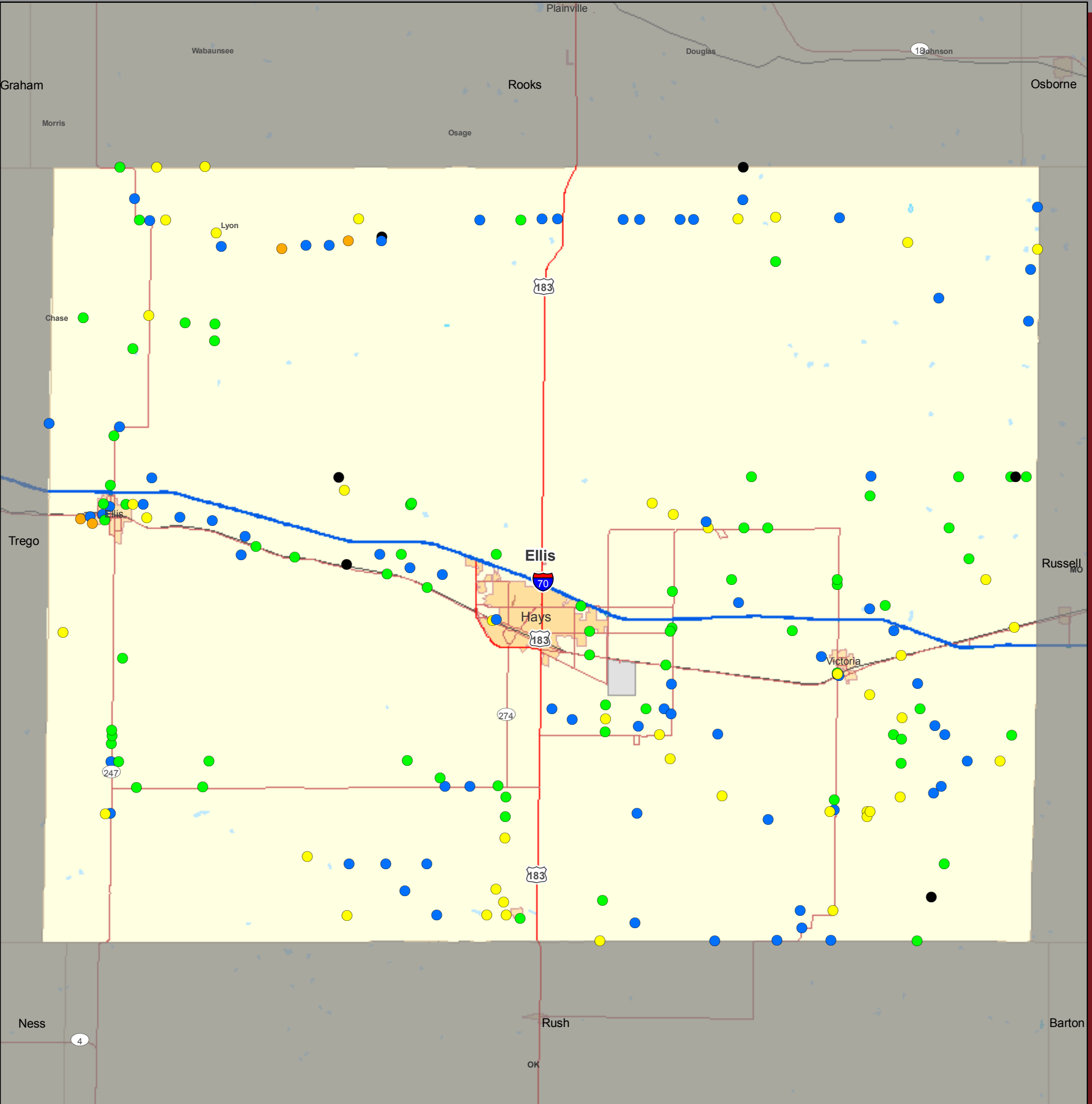

Item 113 Coding

● 3	— Interstate
● 4	— US and State Highways
● 5	— Secondary State and County
● 8	— Local or rural road
⊗ N	- - - - - Railroads
● U	



KDOT Scour Analysis
Item 113 Codes

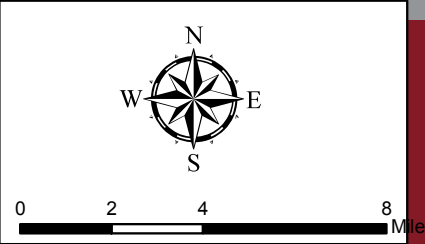

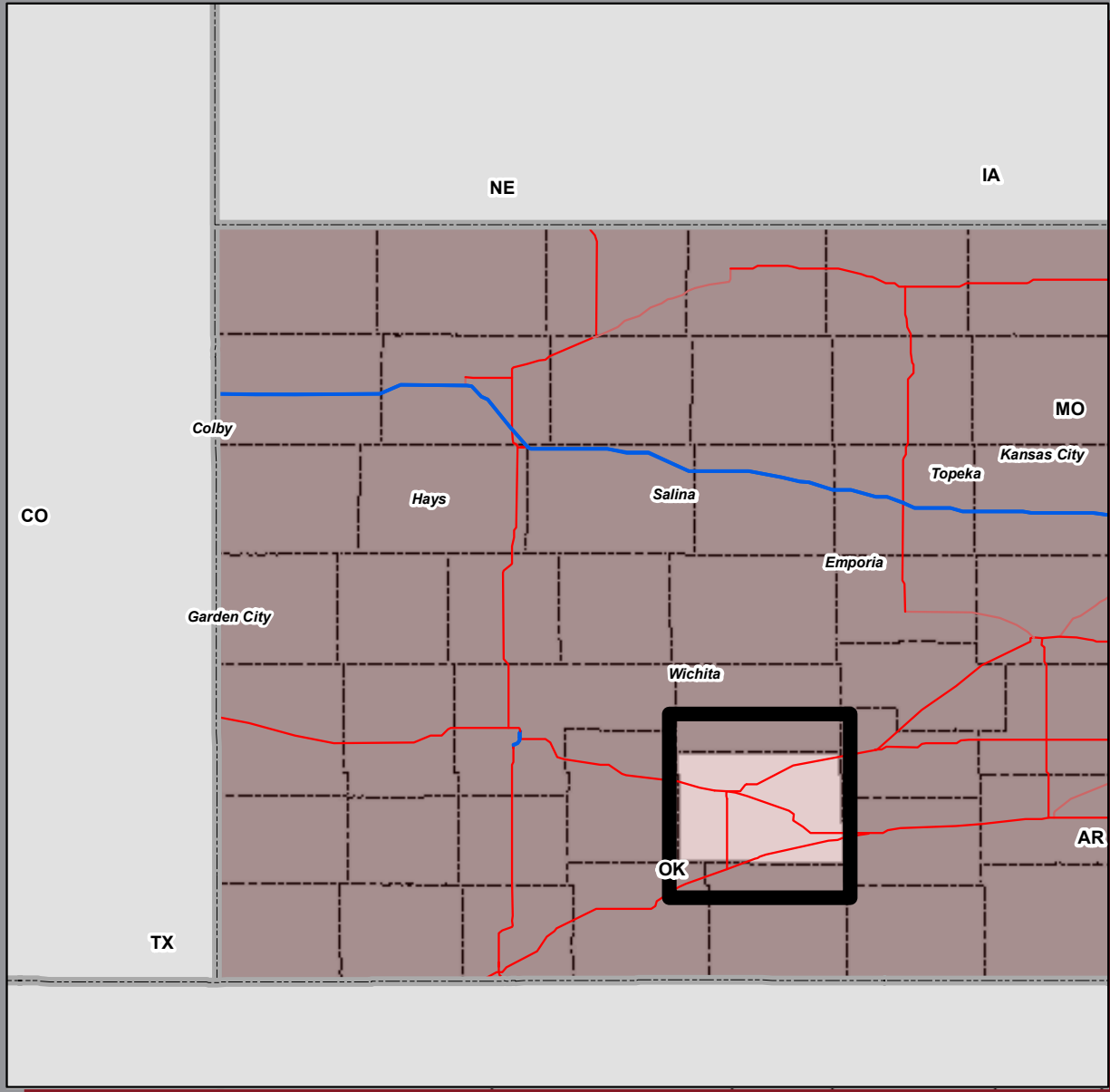
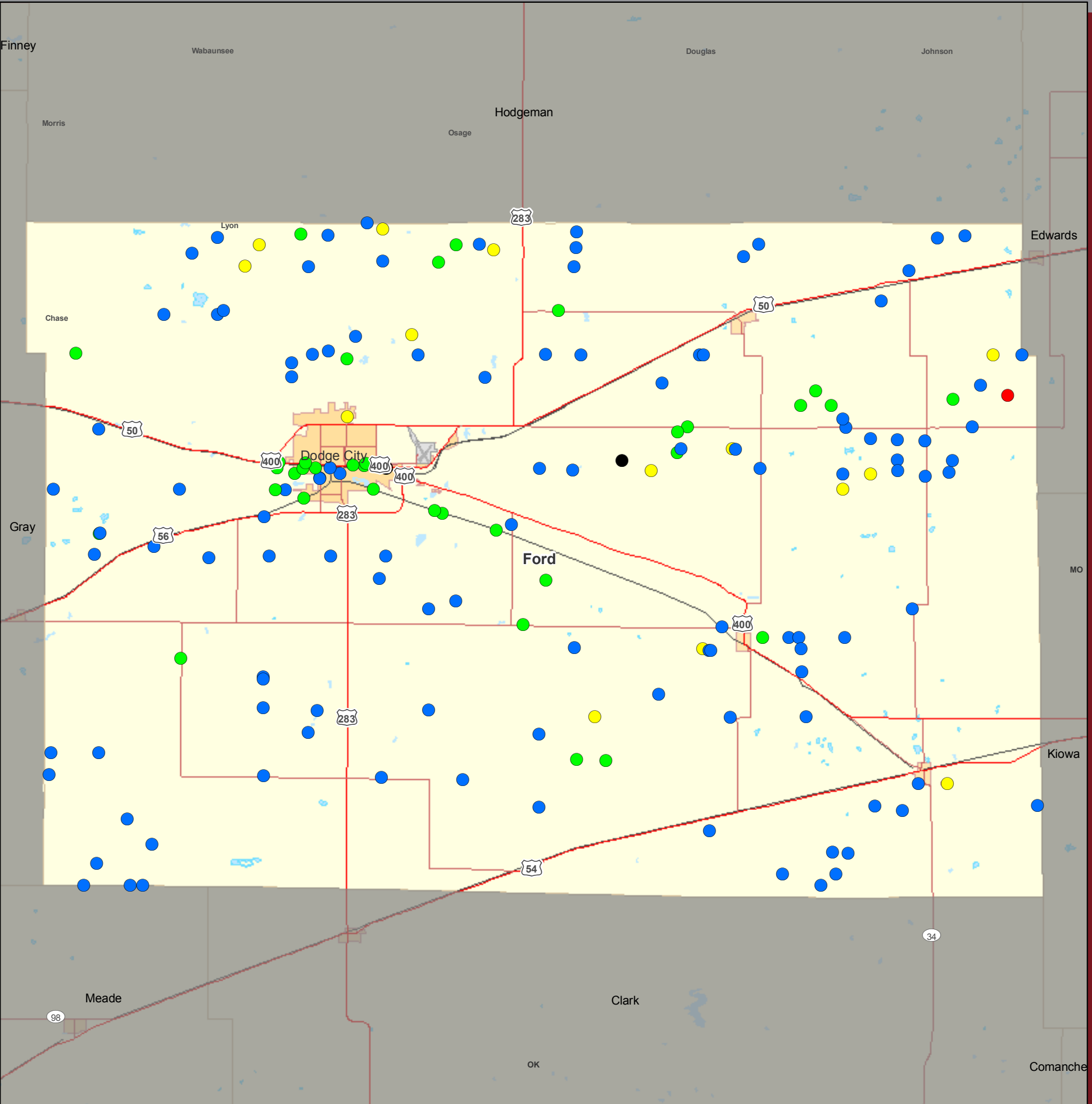

Ford County Item 113 Coding

● 2	— Interstate
● 4	— US and State Highways
● 5	— Secondary State and County
● 8	— Local or rural road
⊗ N	— Railroads
● U	



KDOT Scour Analysis
Item 113 Codes

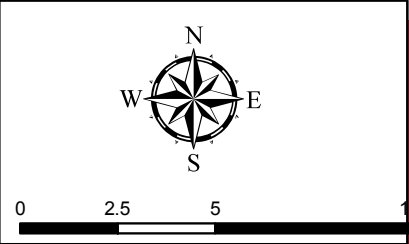

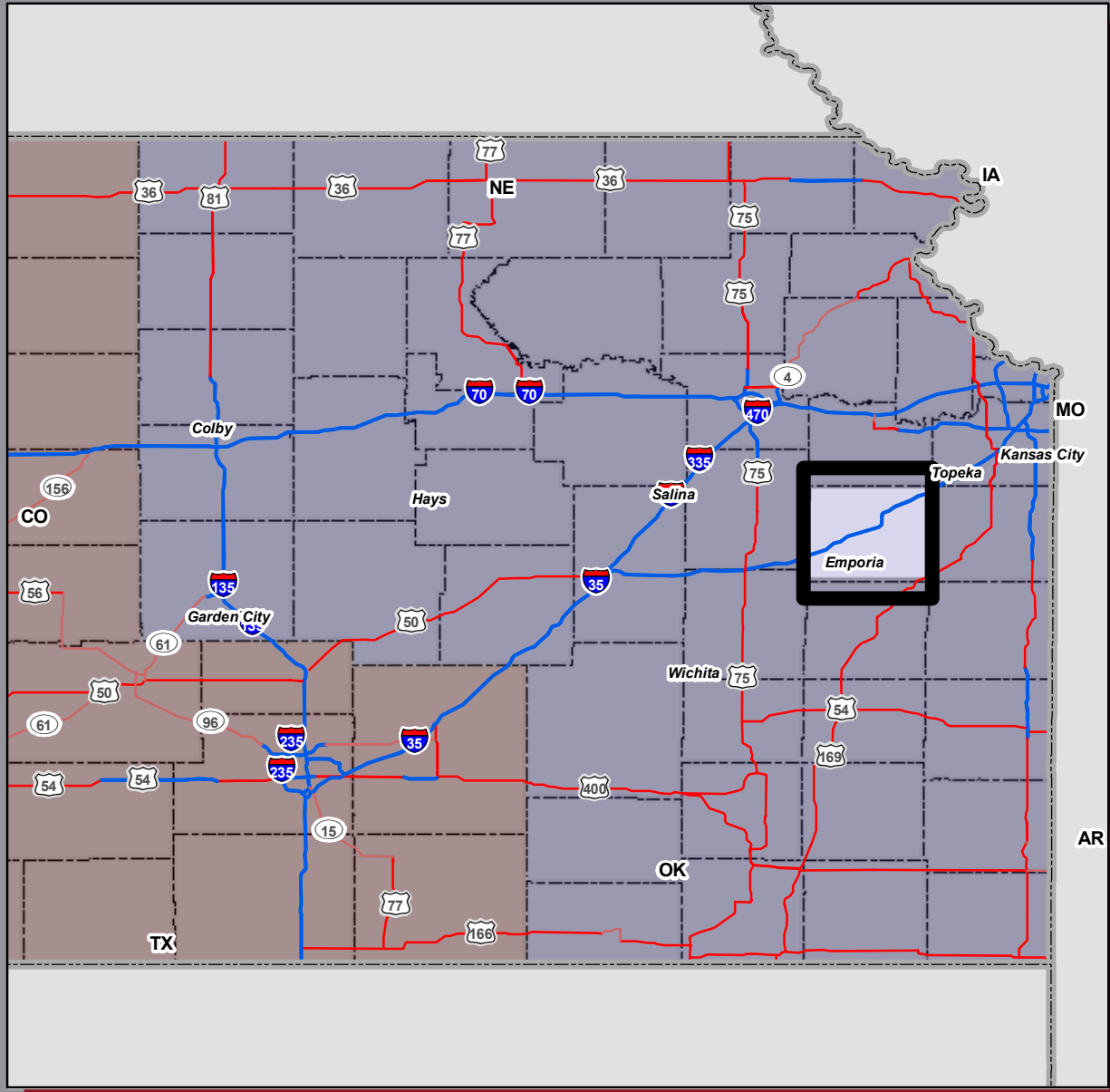
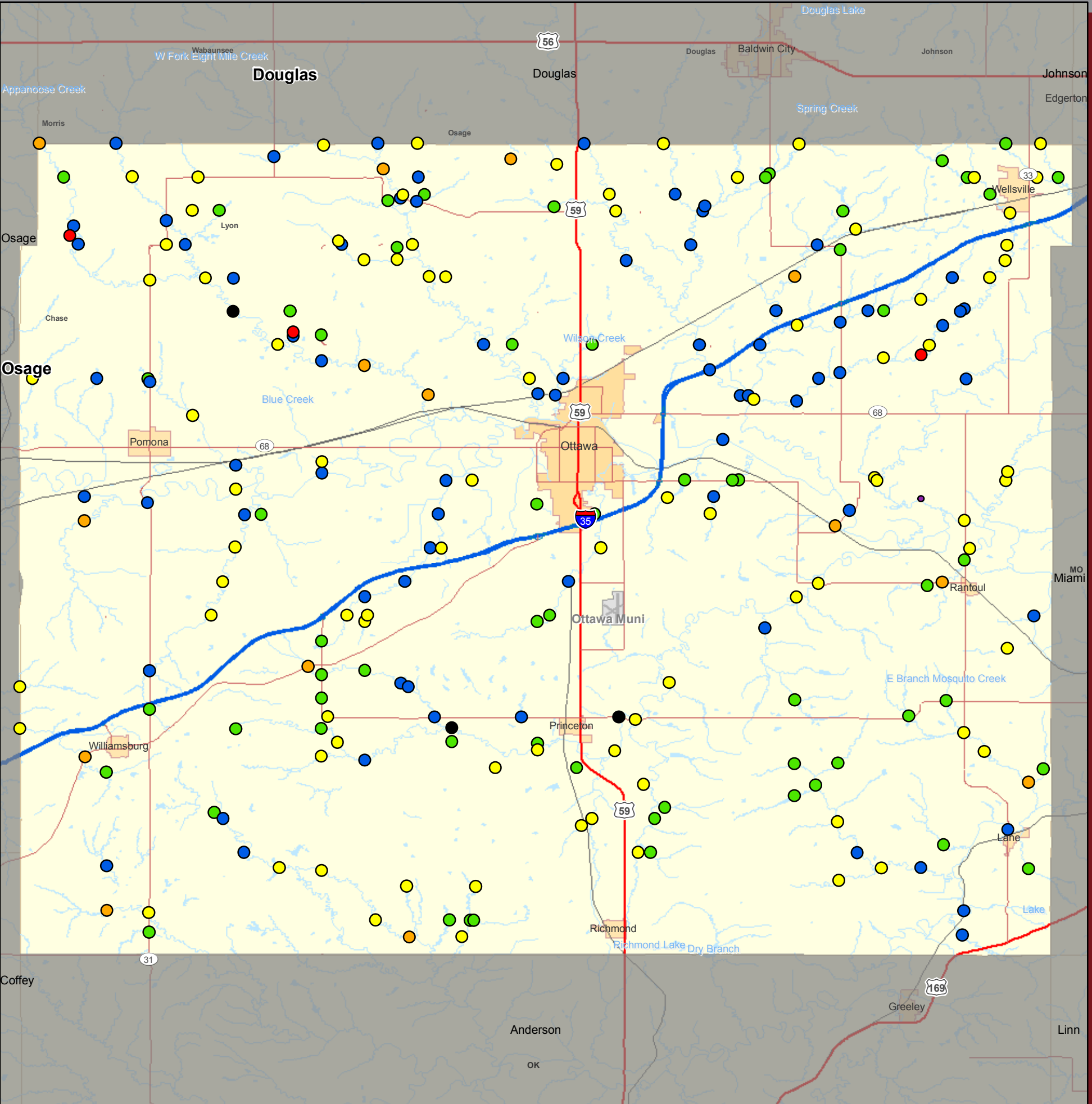

Franklin County Item 113 Code

●	2	— Interstate
●	3	— US and State Highways
●	4	— Secondary State and County
●	5	— Local or rural road
●	8	— Railroads
●	U	

KDOT Scour Analysis
Item 113 Codes

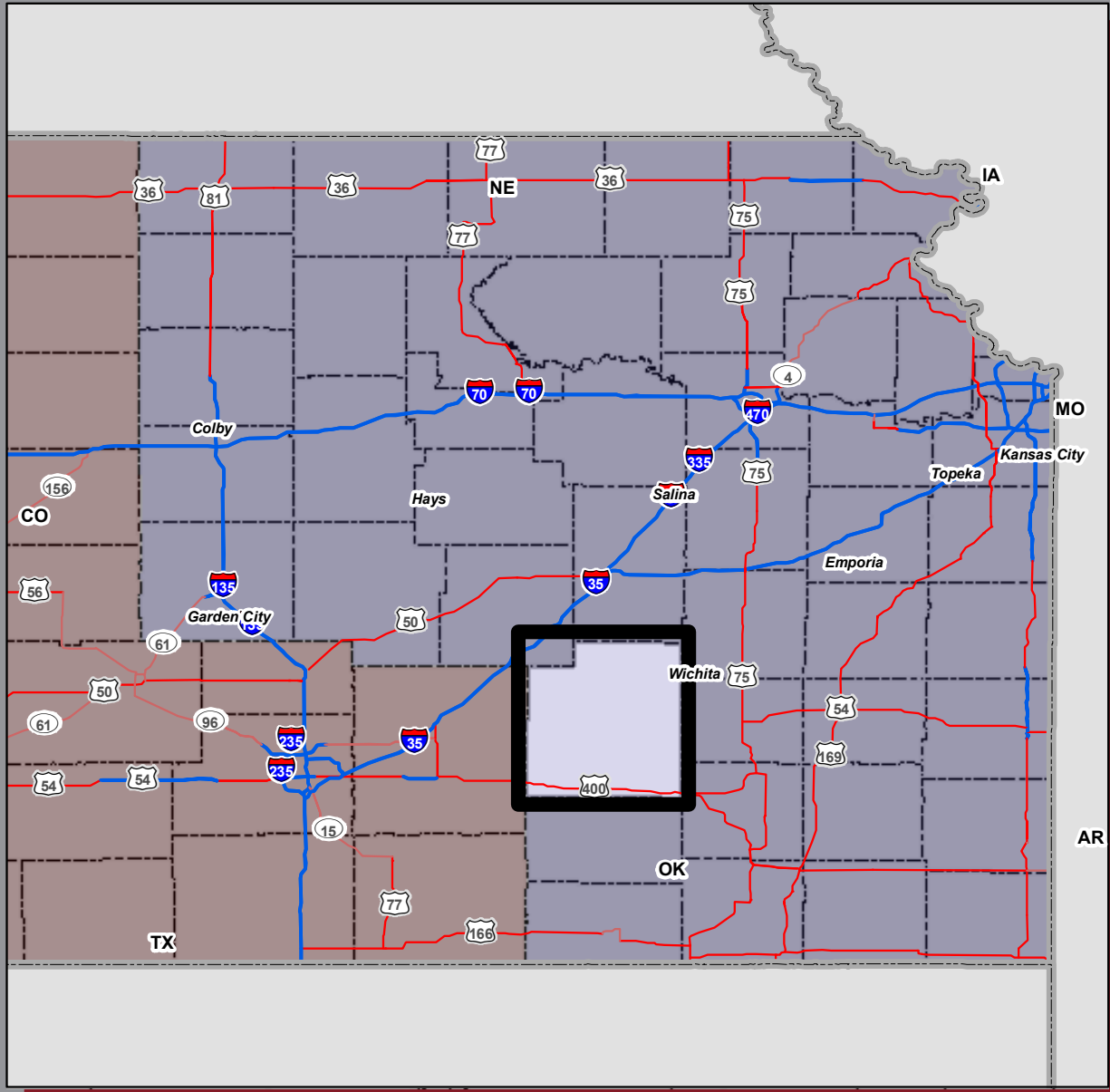
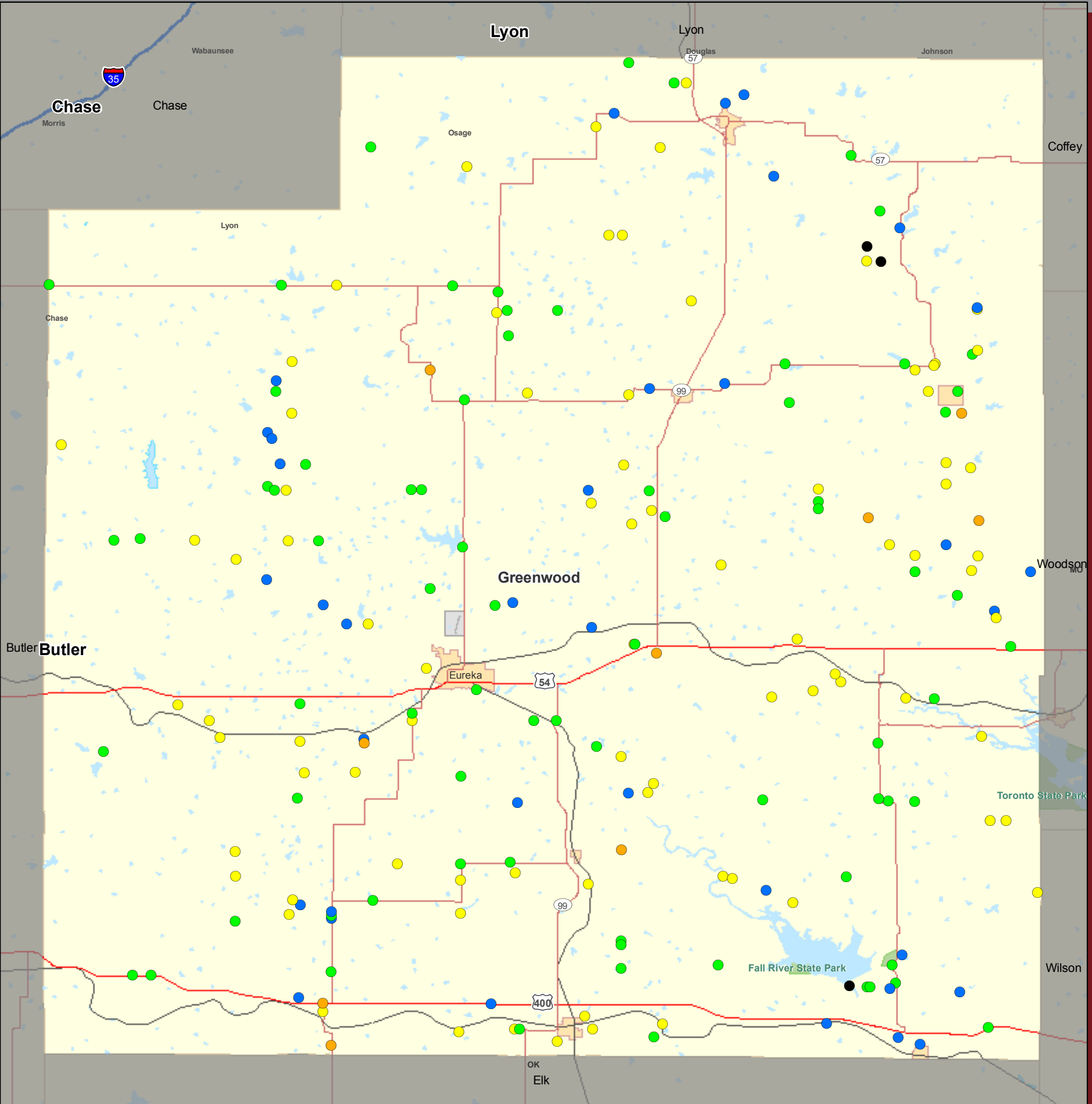

Greenwood County Item 113 Code

- 3
- 4
- 5
- 8
- U

- Interstate
- US and State Highways
- Secondary State and County
- Local or rural road
- + + + + + Railroads



KDOT Scour Analysis
Item 113 Codes

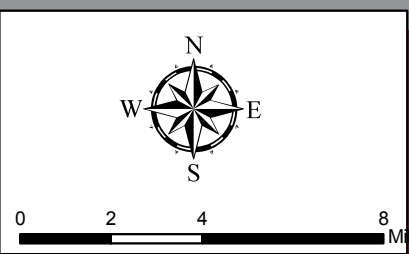

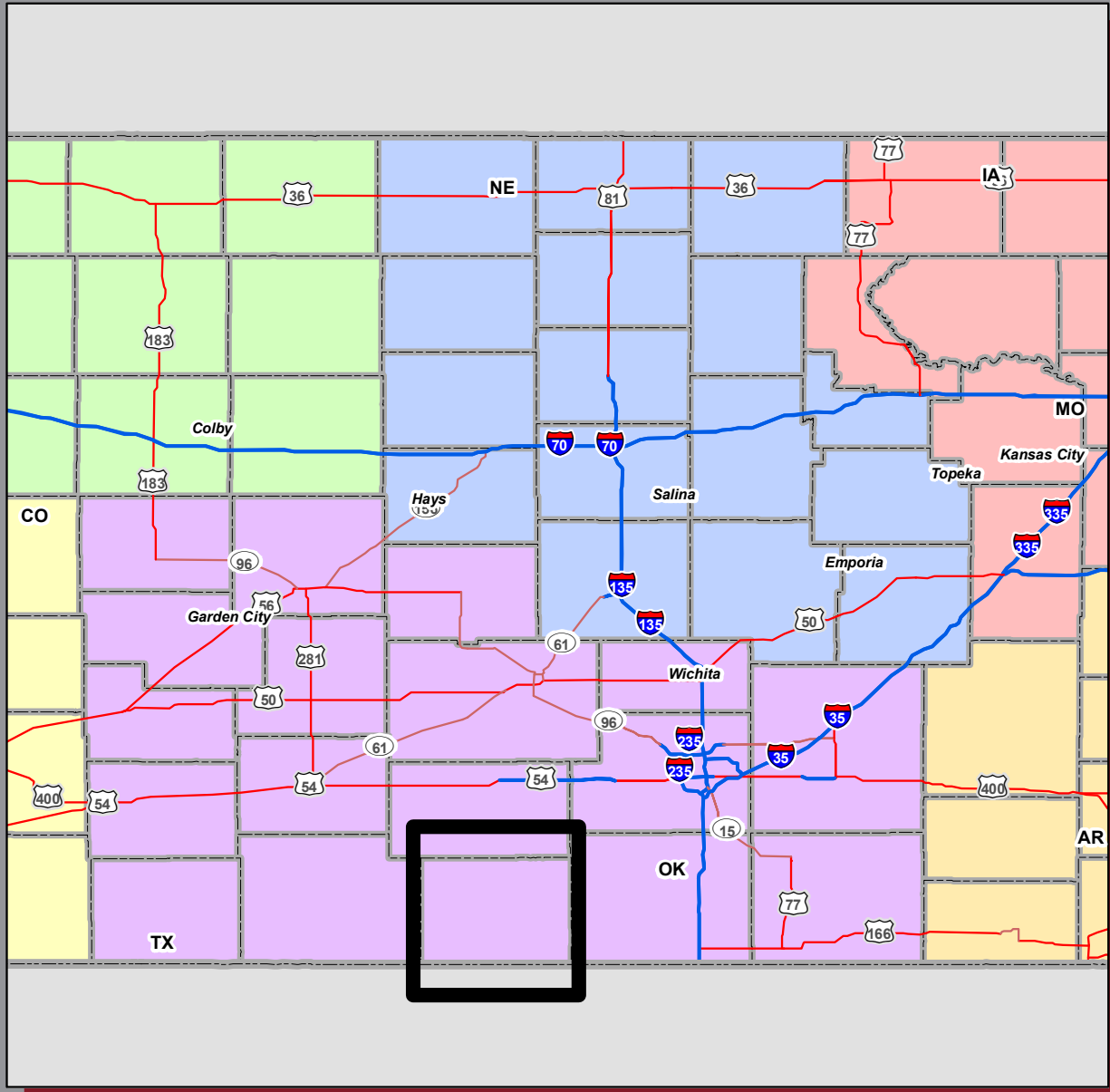
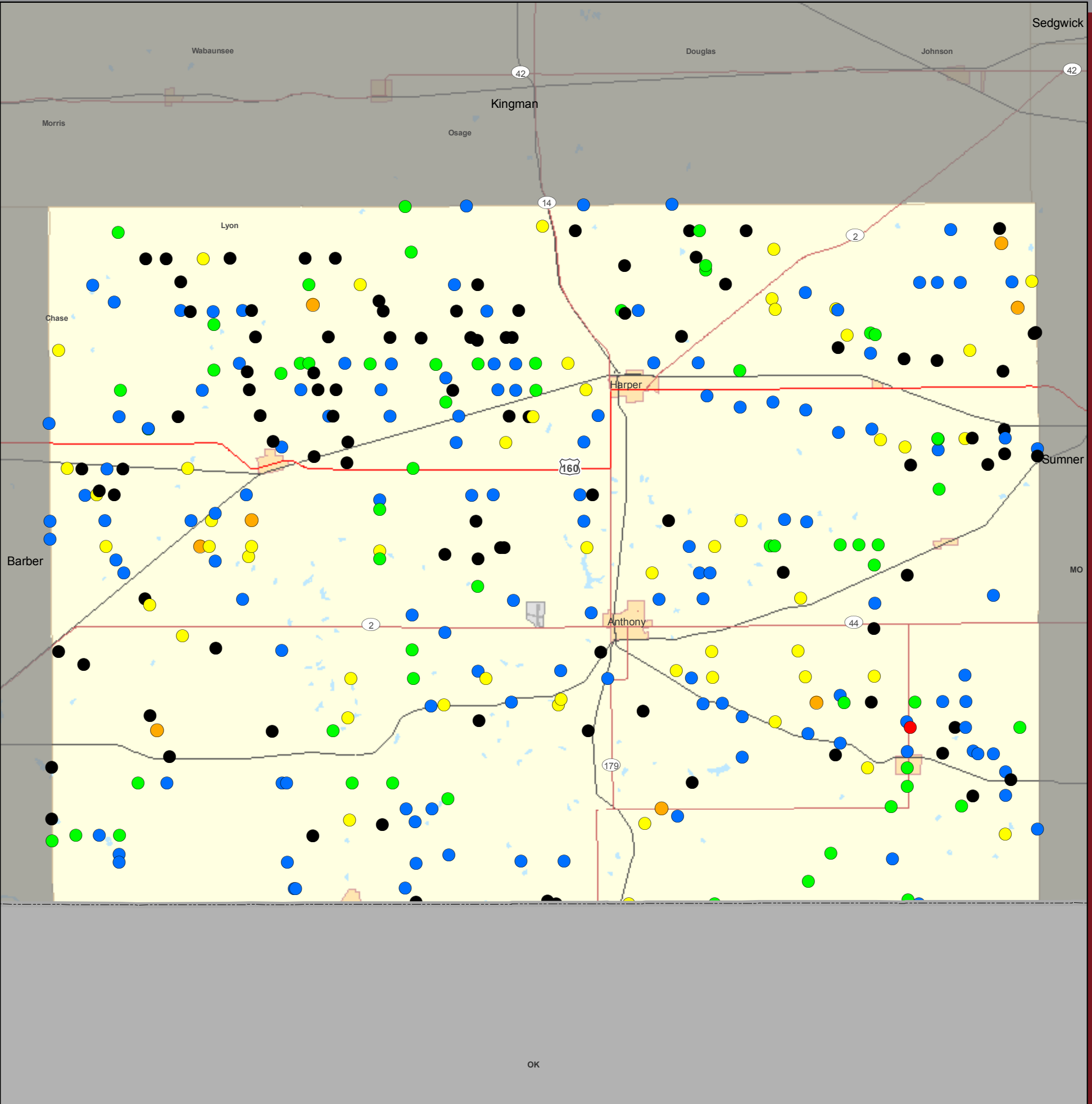

Harper County Item 113 Coding

● 2	— Interstate
● 3	— US and State Highways
● 4	— Secondary State and County
● 5	— Local or rural road
● 8	+++++ Railroads
● U	



KDOT Scour Analysis
Item 113 Codes

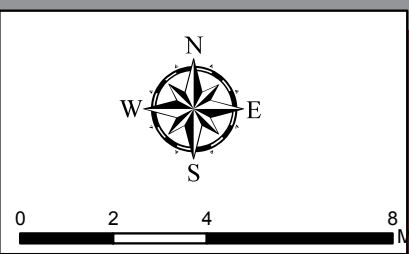

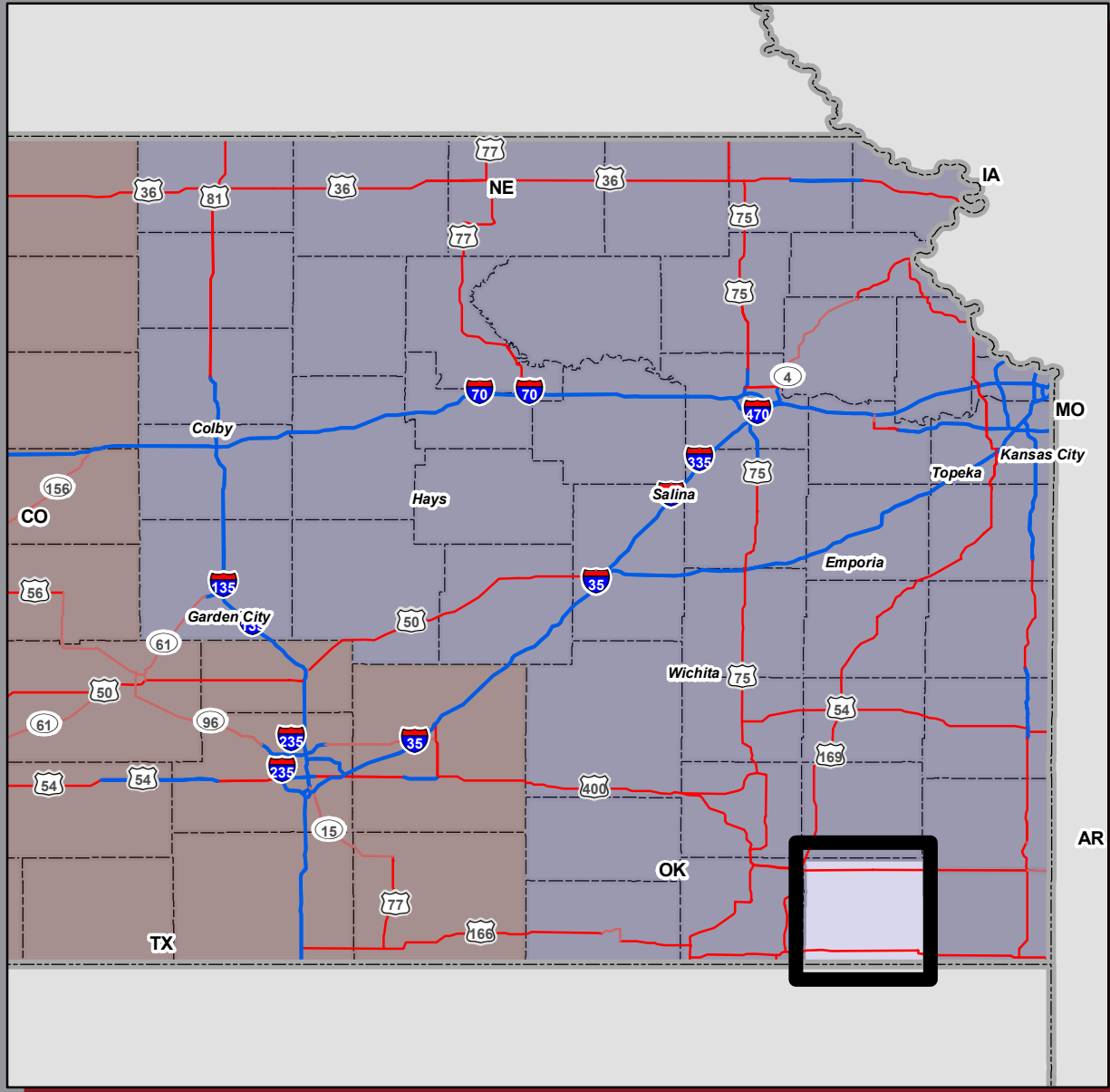
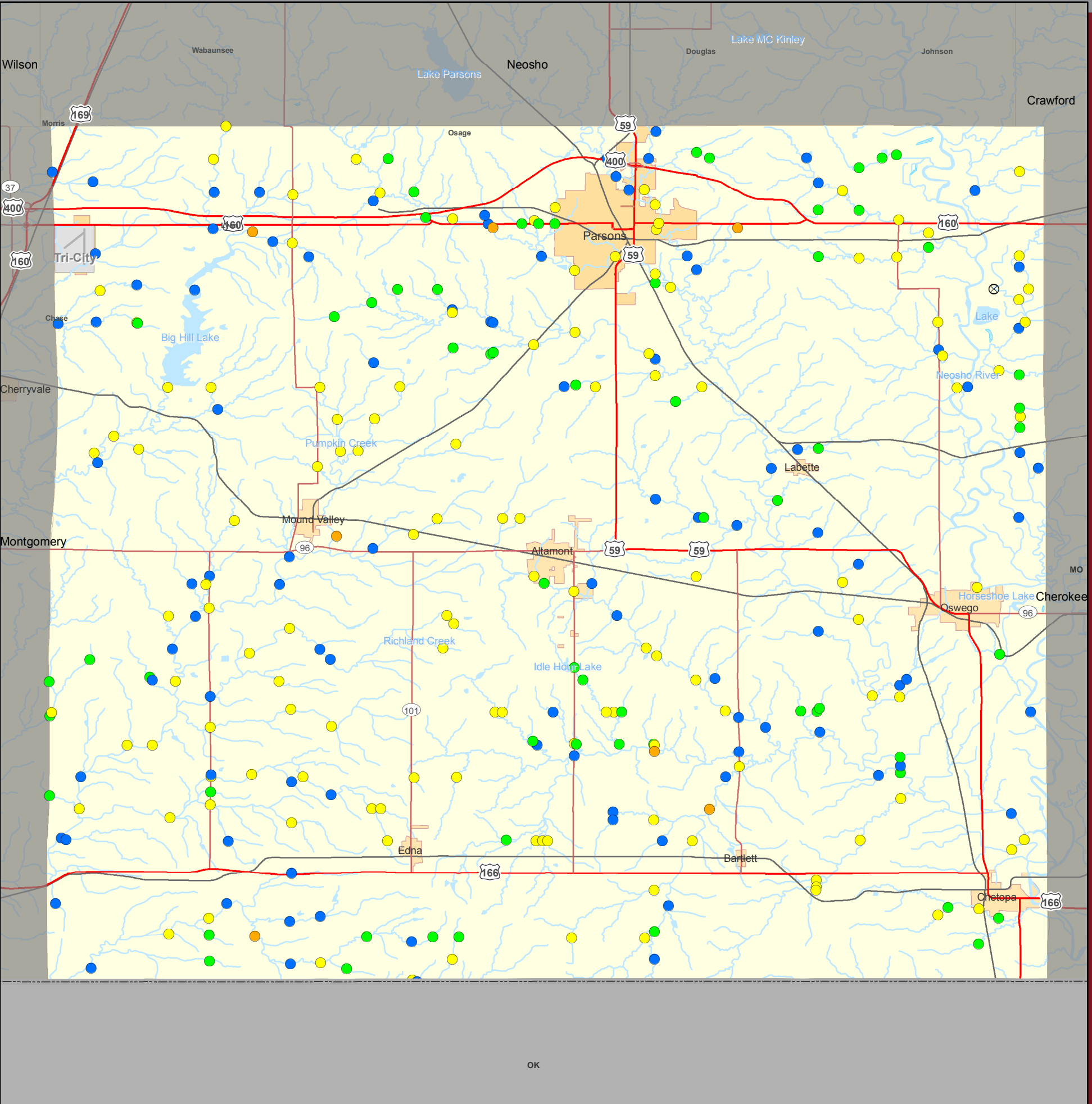

Item 113 Coding

- ⊗ 0
- 3
- 4
- 5
- 8

- Interstate
- US and State Highways
- Secondary State and County
- Local or rural road
- +++++ Railroads



KDOT Scour Analysis
Item 113 Codes

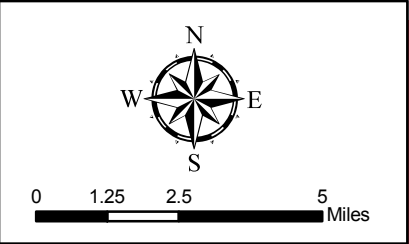

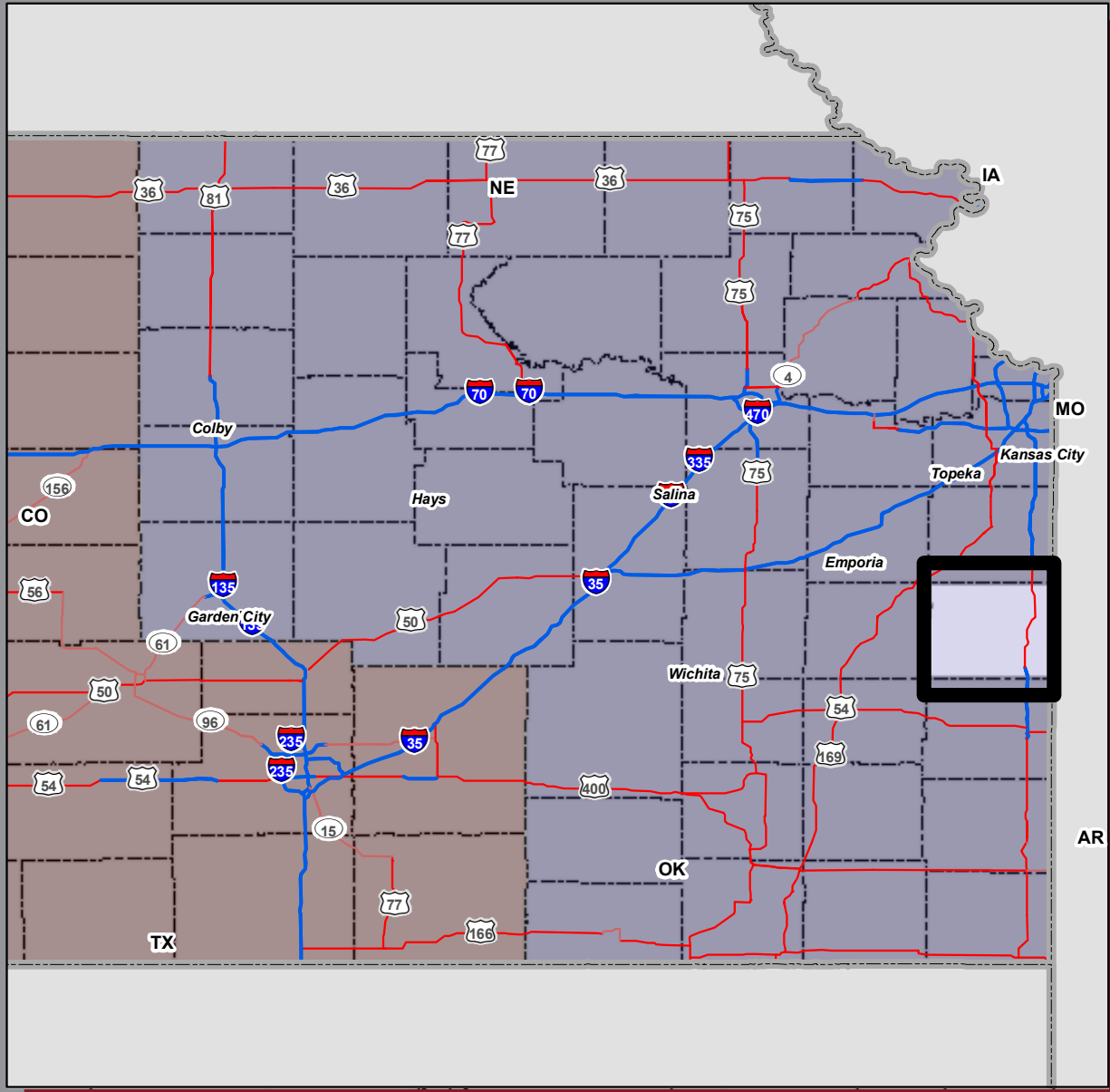
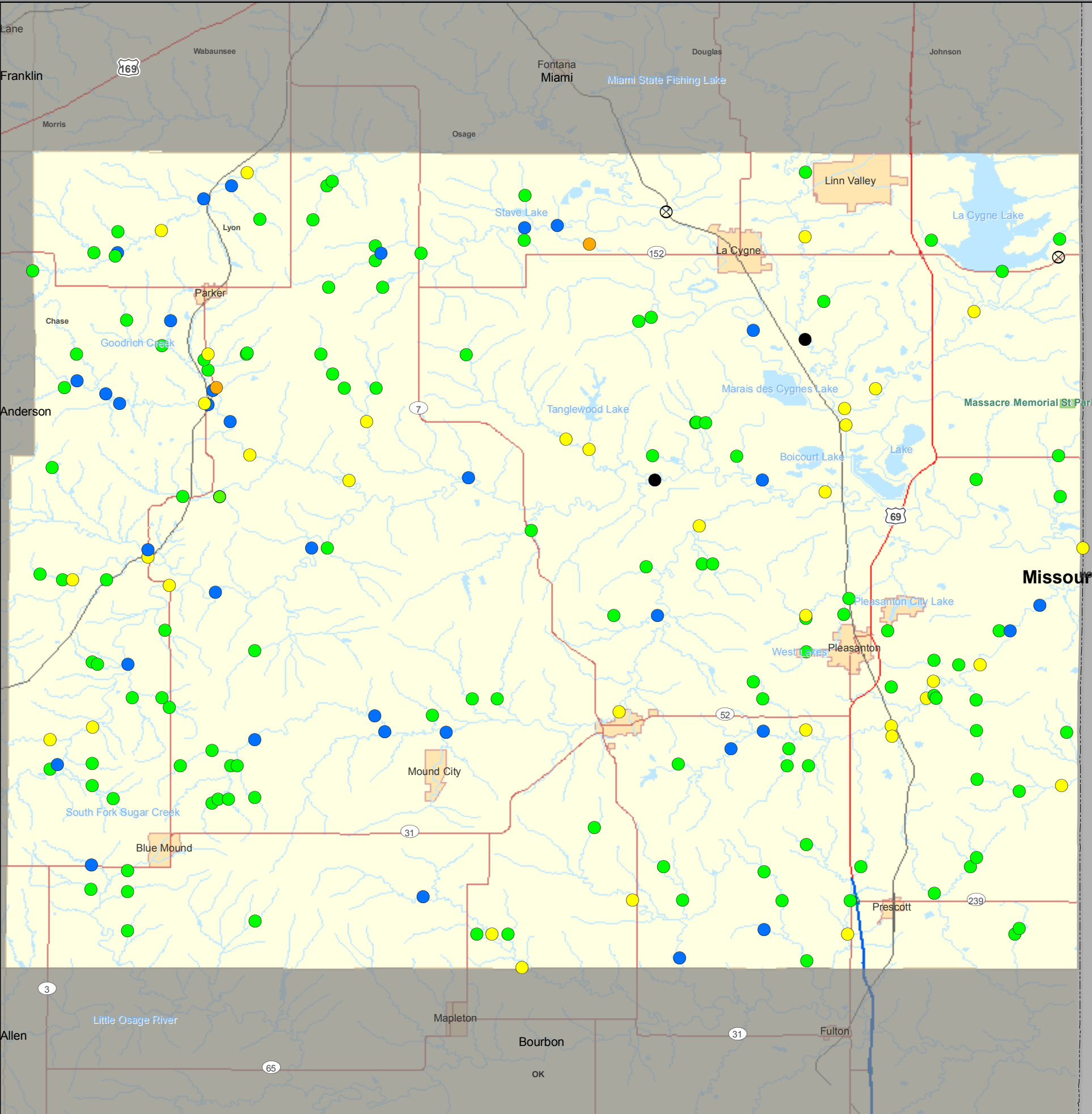

Item 113 Coding

- 3
- 4
- 5
- 8
- ⊗ N
- U

- Interstate
- US and State Highways
- Secondary State and County
- Local or rural road
- +++++ Railroads



KDOT Scour Analysis
Item 113 Codes

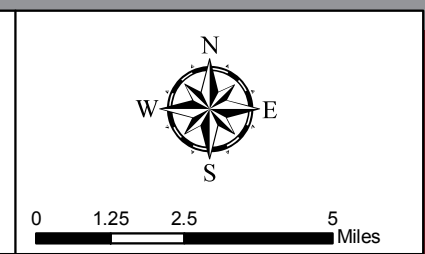

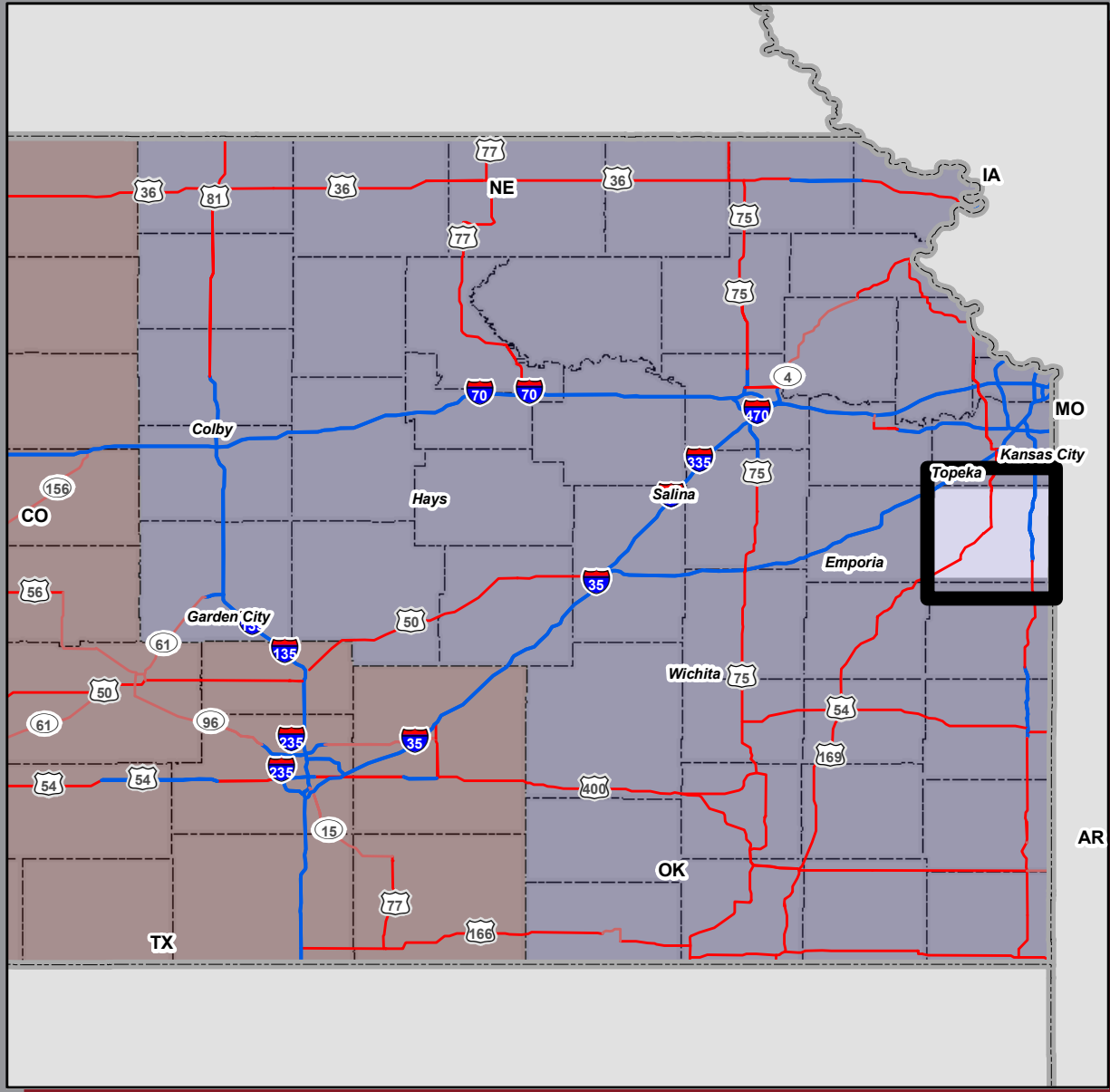
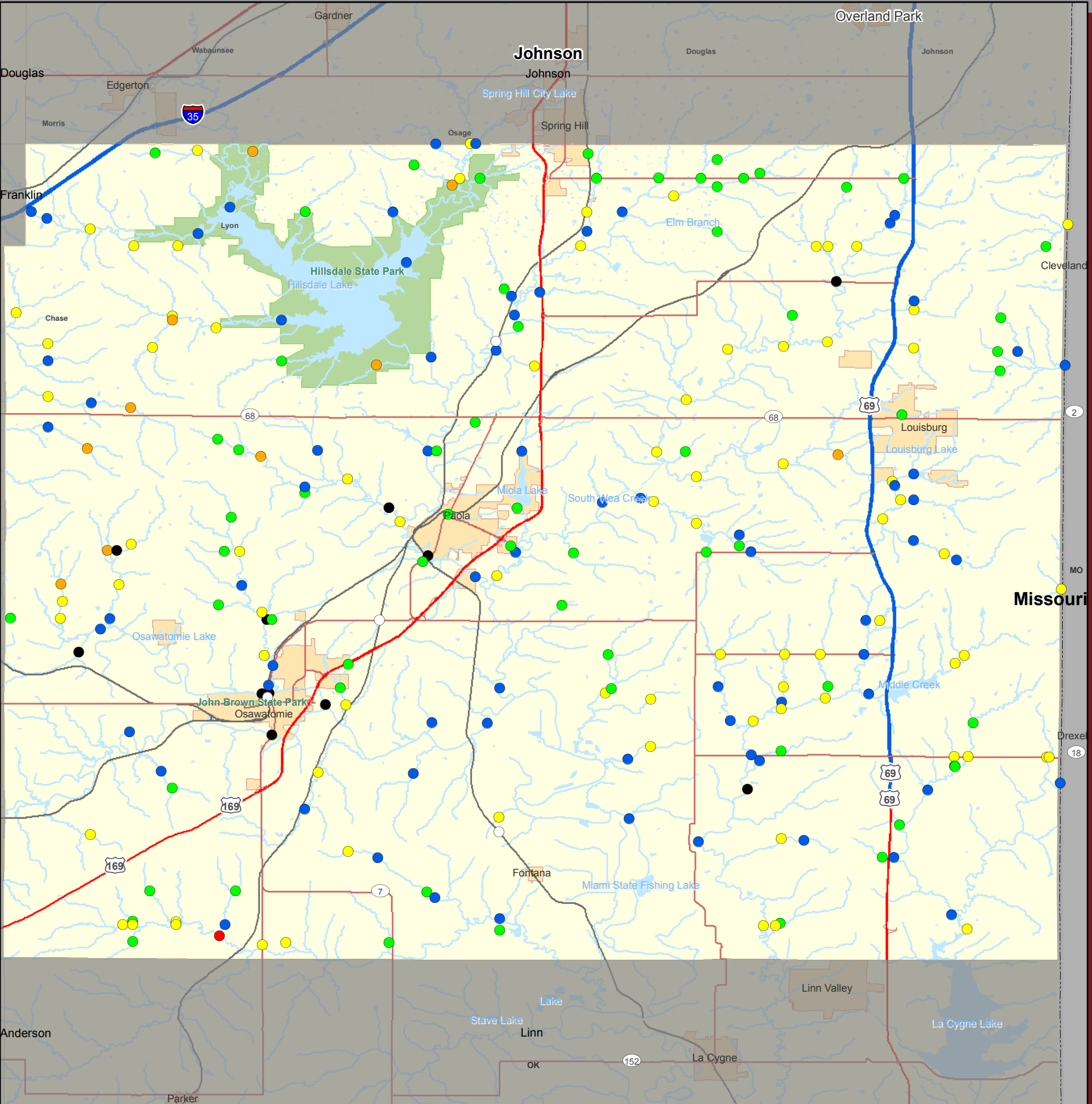

**Miami County Kansas
Item 113 Coding**

● 2	— Interstate
● 3	— US and State Highways
● 4	— Secondary State and County
● 5	— Local or rural road
● 8	— Railroads
○ N	
● U	



KDOT Scour Analysis
Item 113 Codes

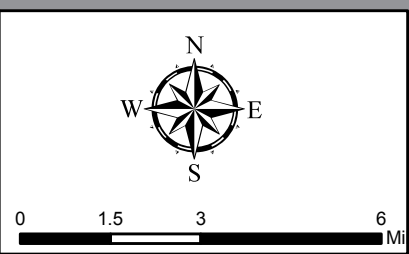

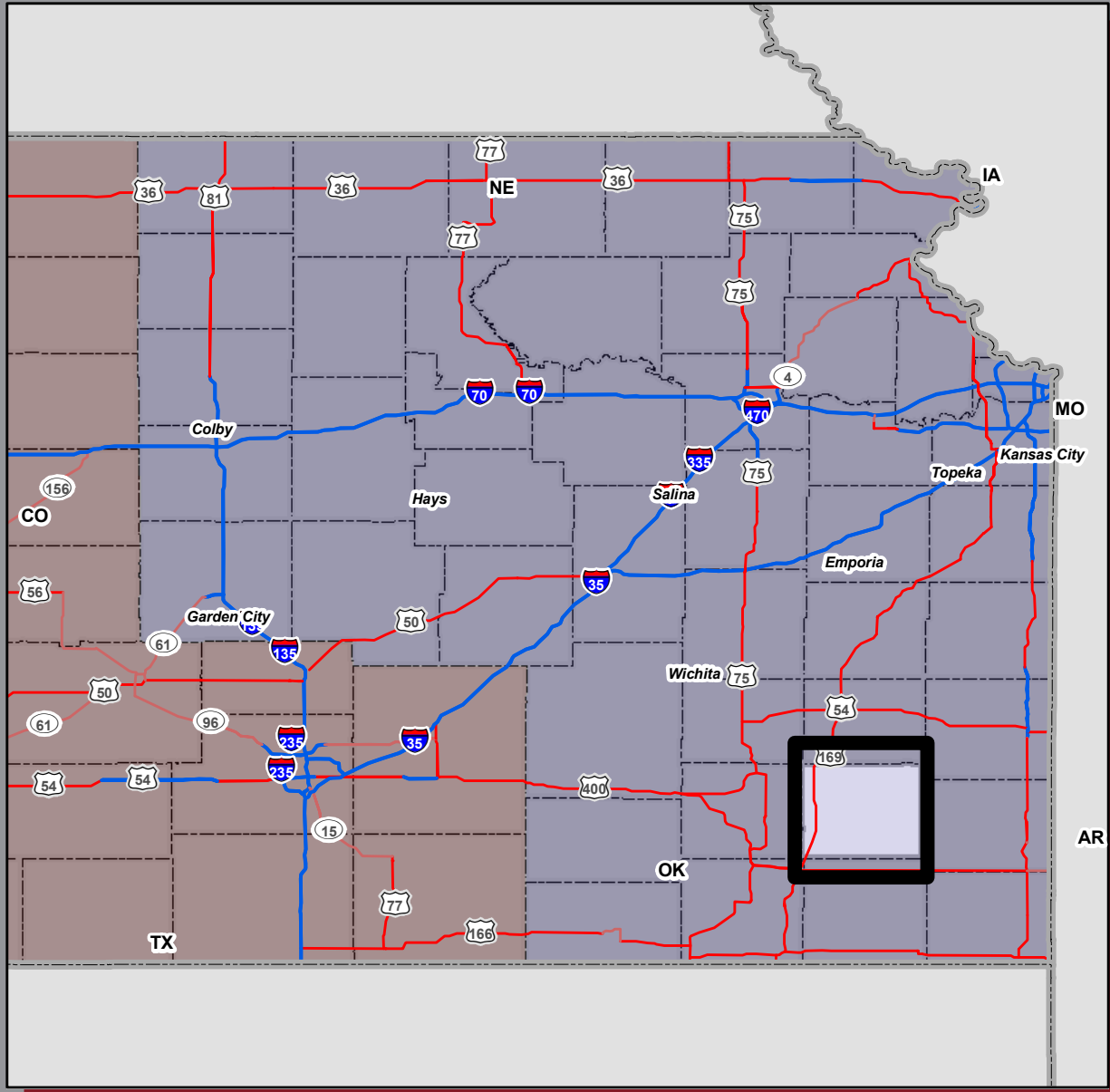
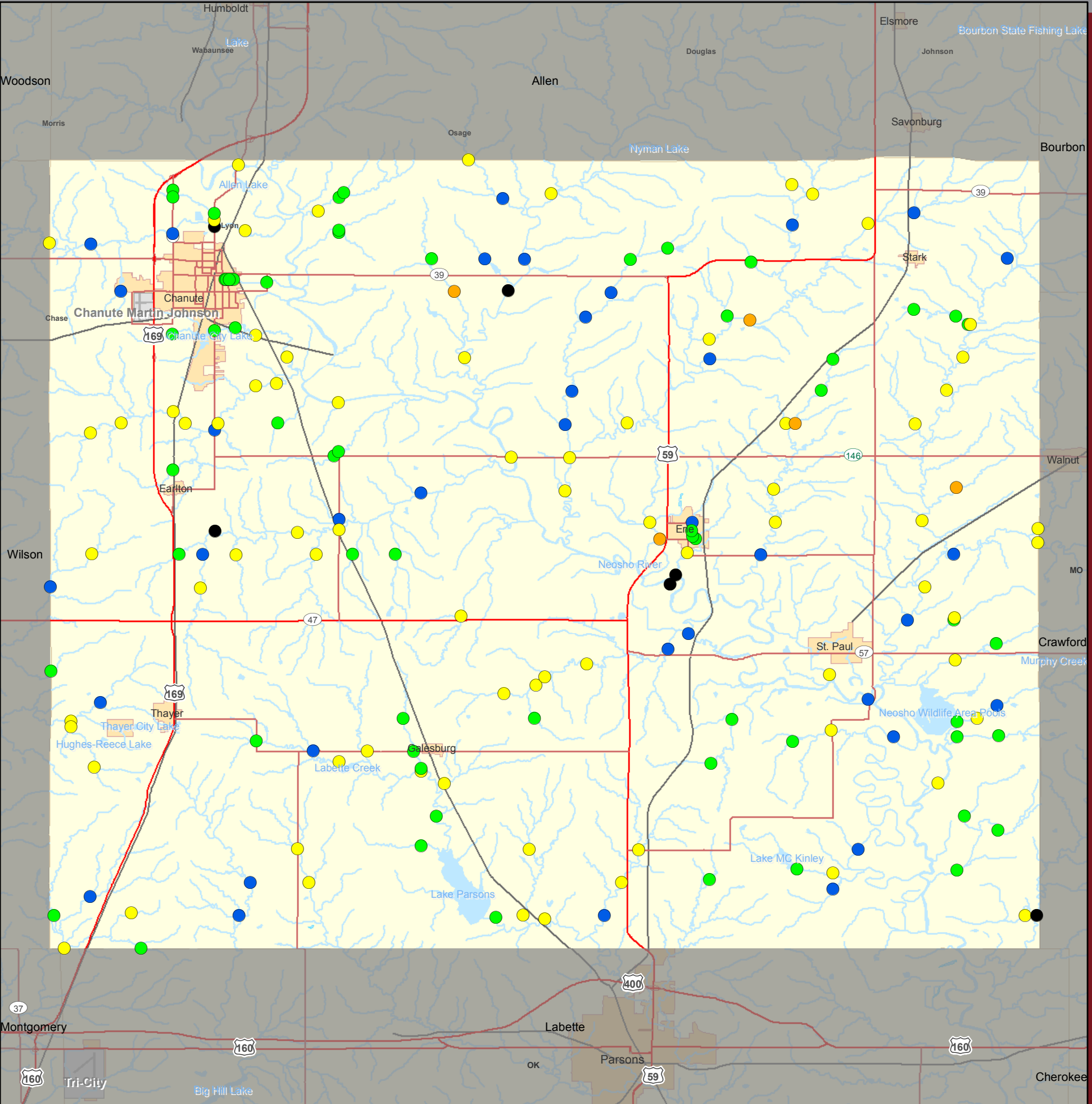

Neosho County Item 113 Coding

● 3	— Interstate
● 4	— US and State Highways
● 5	— Secondary State and County
● 8	— Local or rural road
● U	+ + + + + Railroads
○ N	

KDOT Scour Analysis
Item 113 Codes

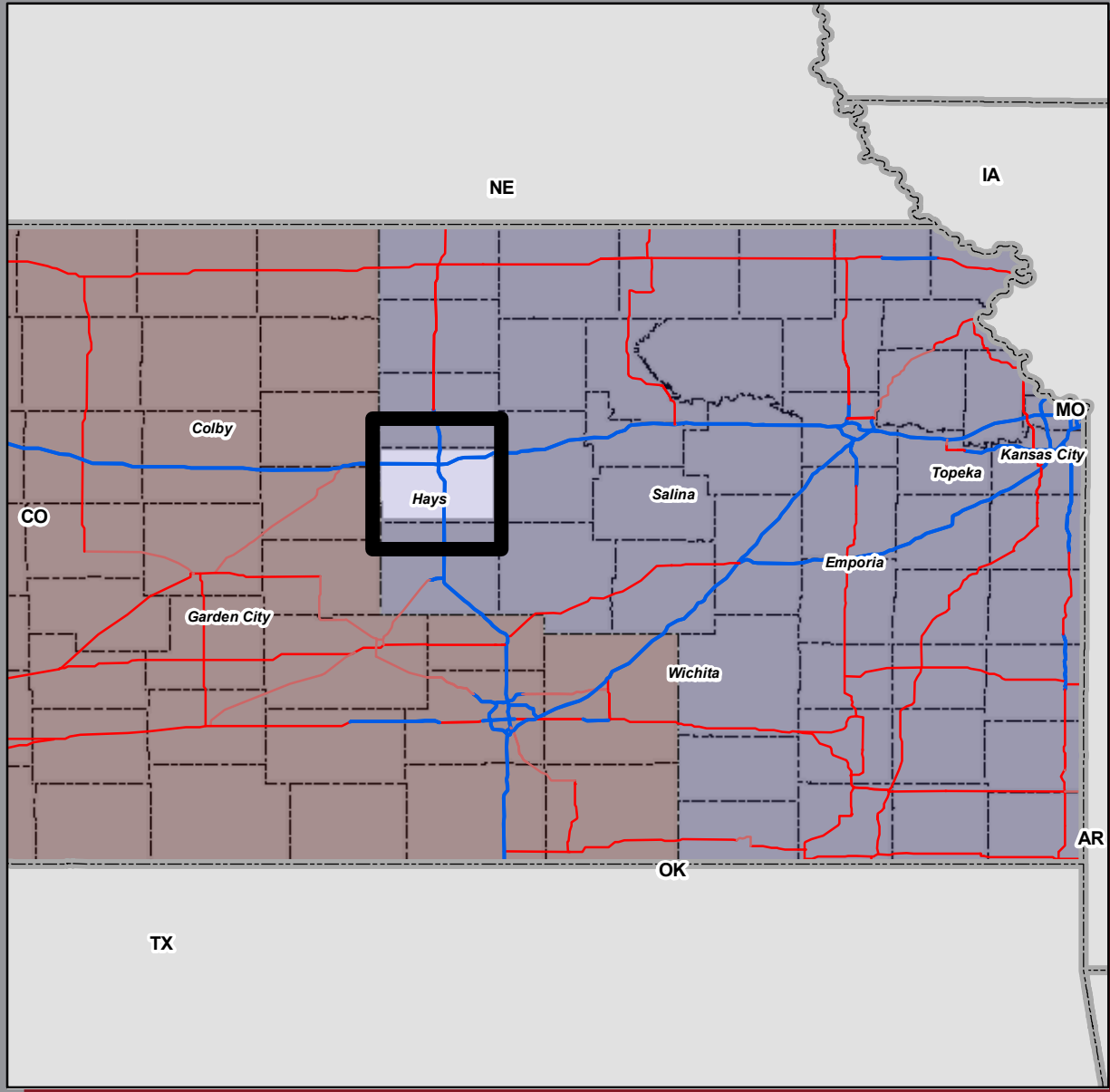
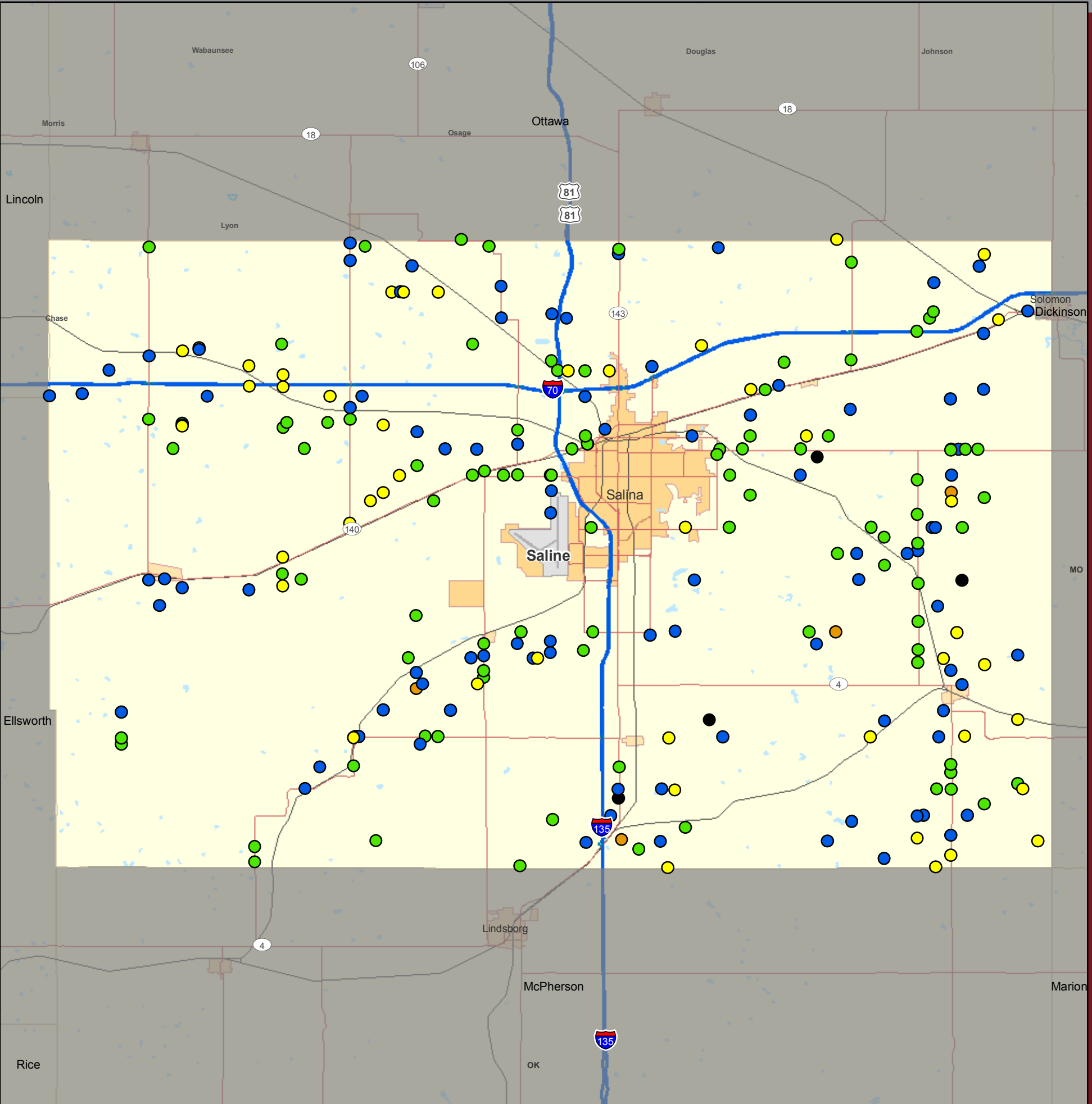

Saline County Item 113 Code

3	Interstate
4	US and State Highways
5	Secondary State and County
8	Local or rural road
U	Railroads



KDOT Scour Analysis
Item 113 Codes

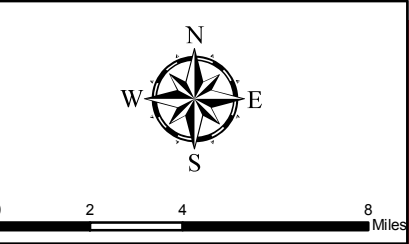

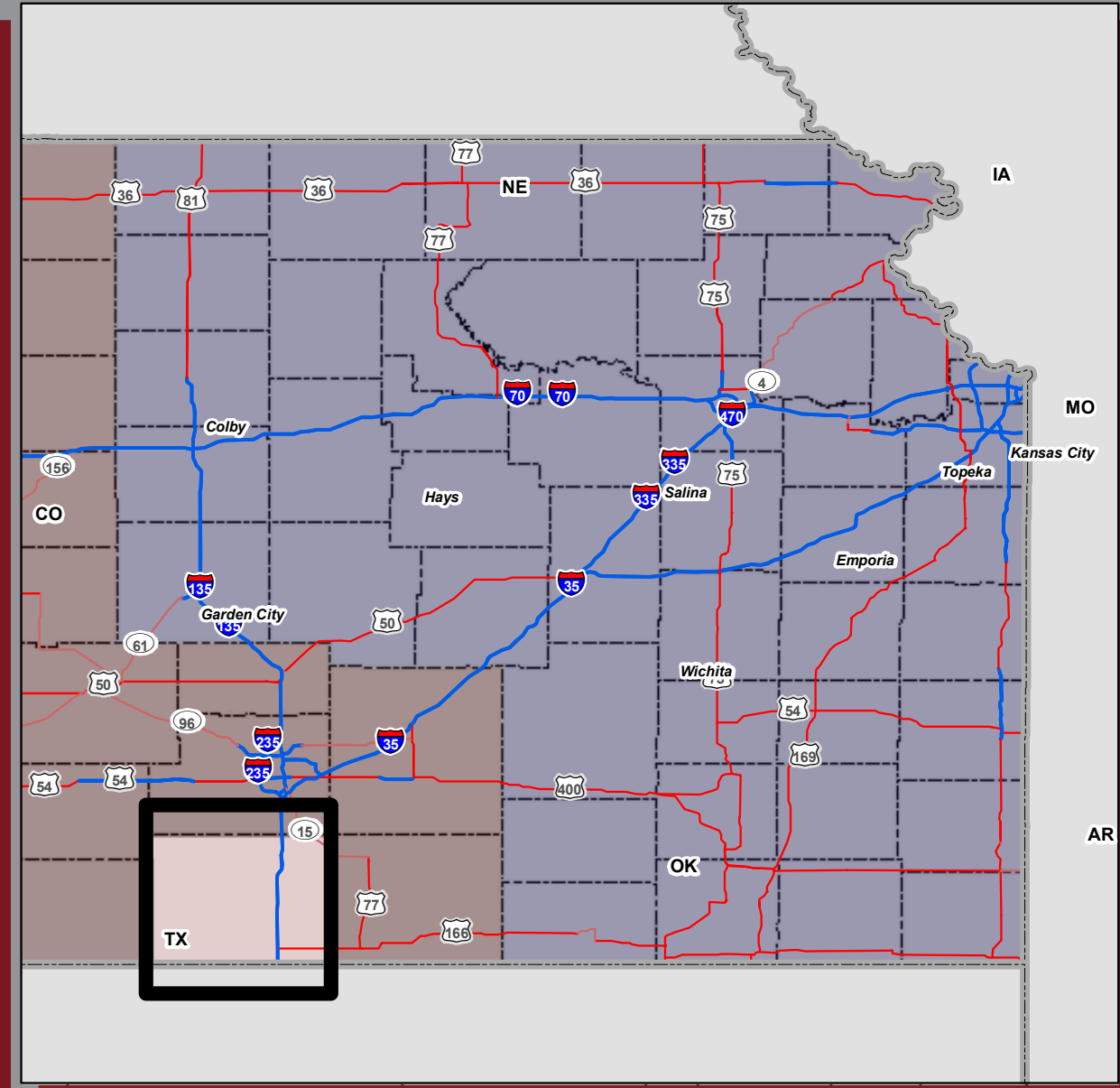
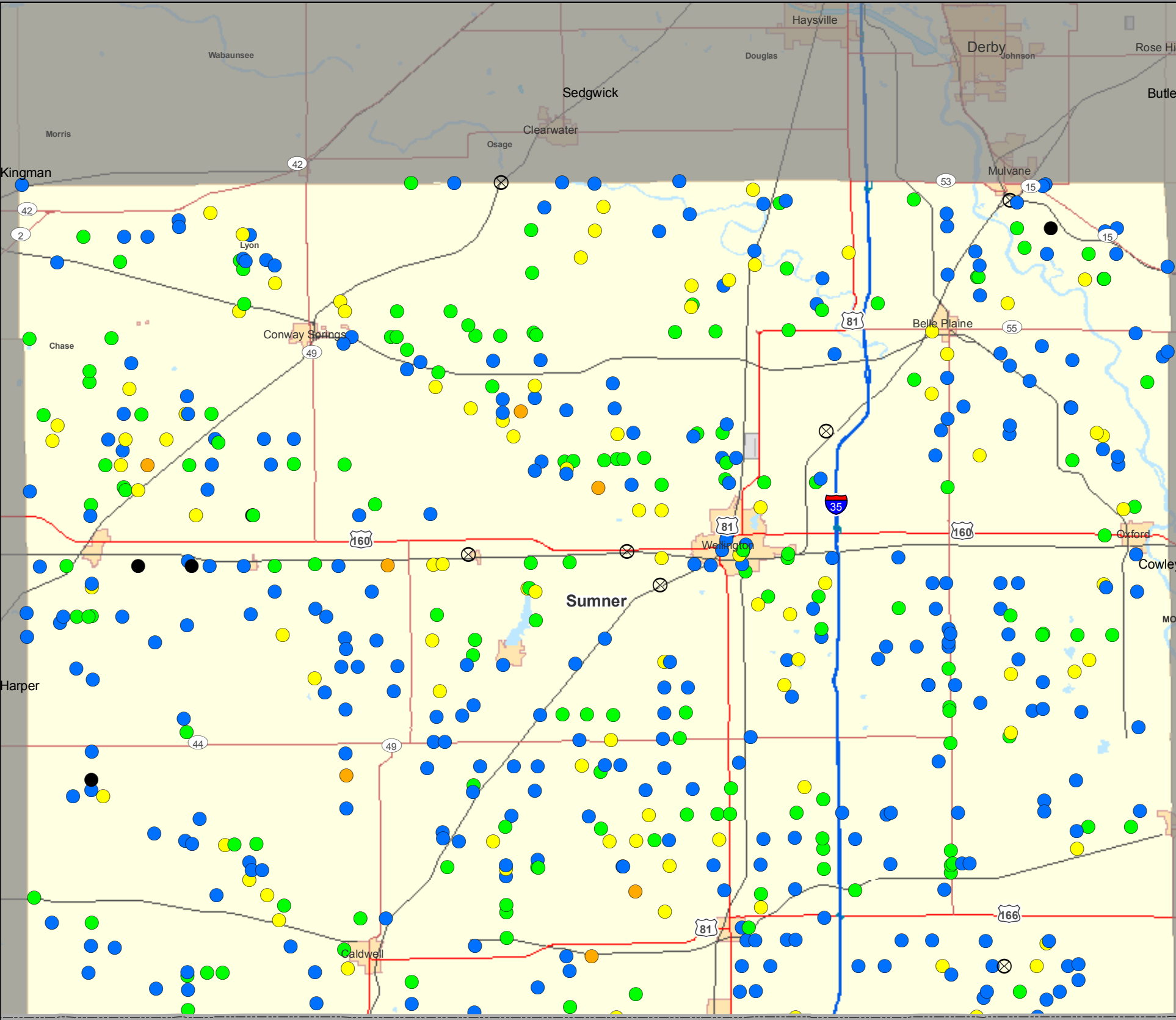

Sumner County Item 113 Coding

● 3	— Interstate
● 4	— US and State Highways
● 5	— Secondary State and County
● 8	— Local or rural road
⊗ N	—+—+—+— Railroads
● U	



KDOT Scour Analysis
Item 113 Codes

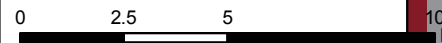
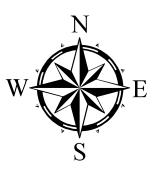

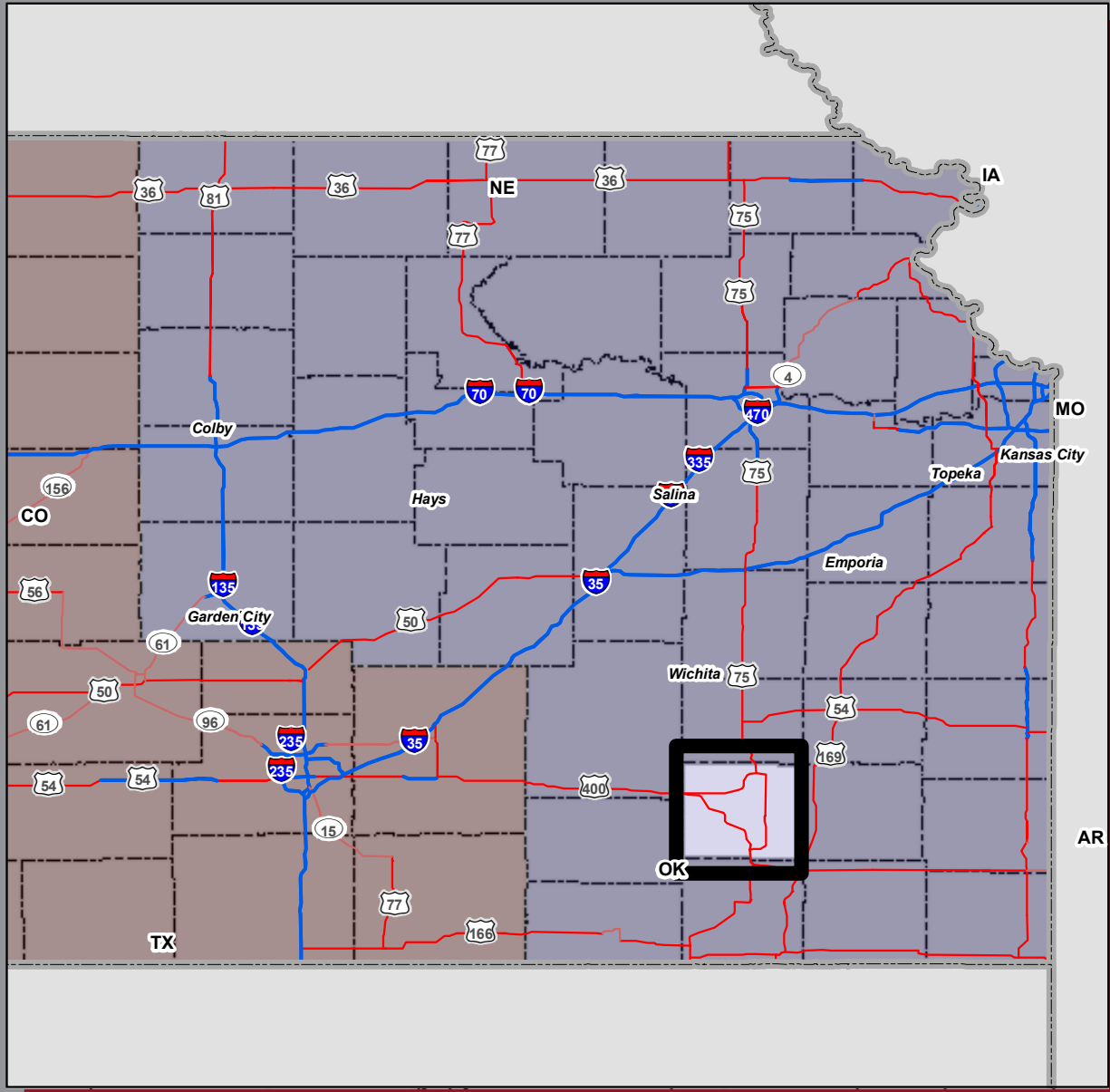
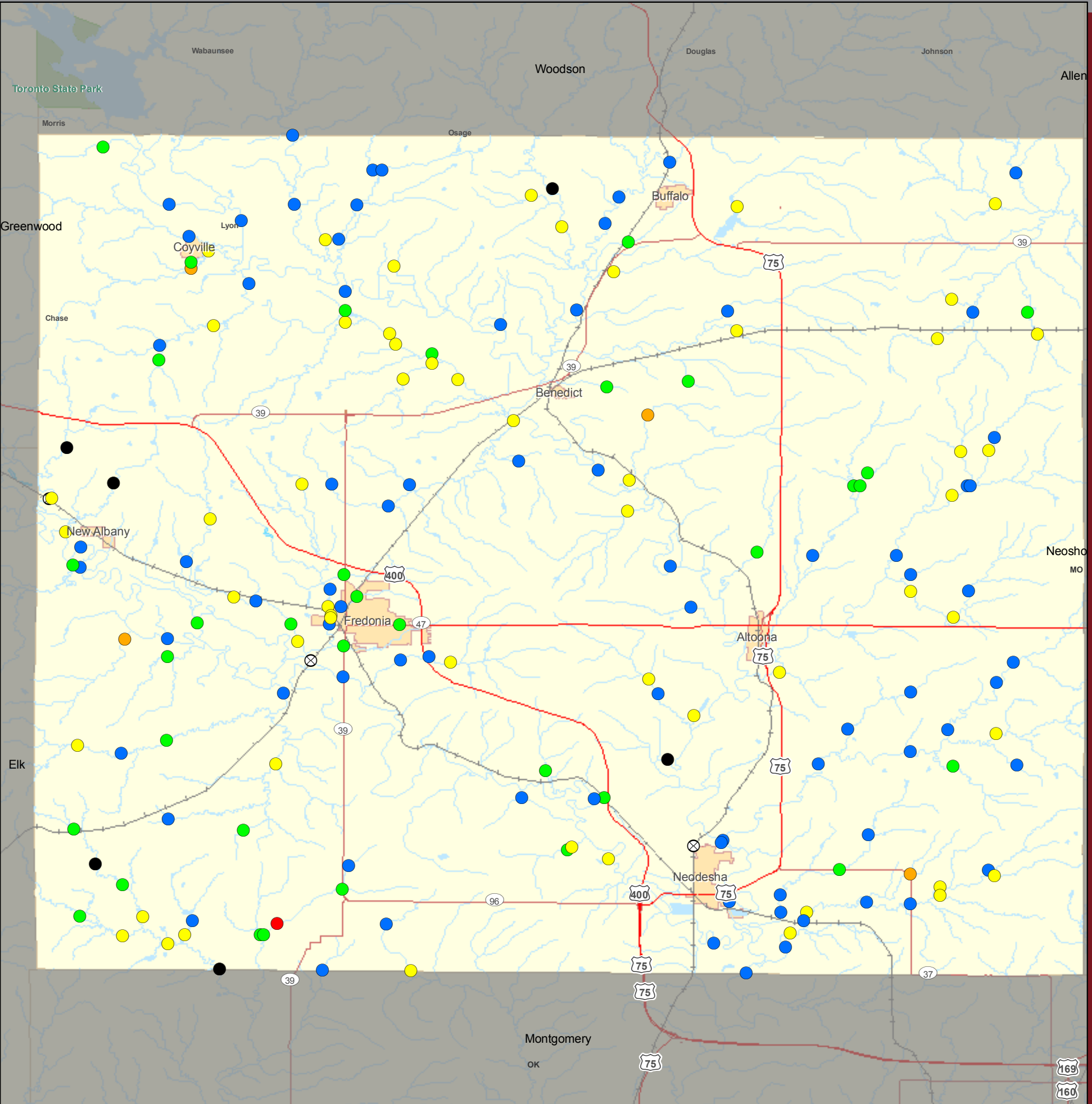

Wilson County Item 113 Coding

● 1	— Interstate
● 3	— US and State Highways
● 4	— Secondary State and County
● 5	— Local or rural road
● 8	— Railroads
⊗ N	
● U	

KDOT Scour Analysis
Item 113 Codes

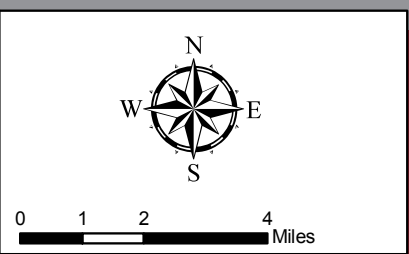

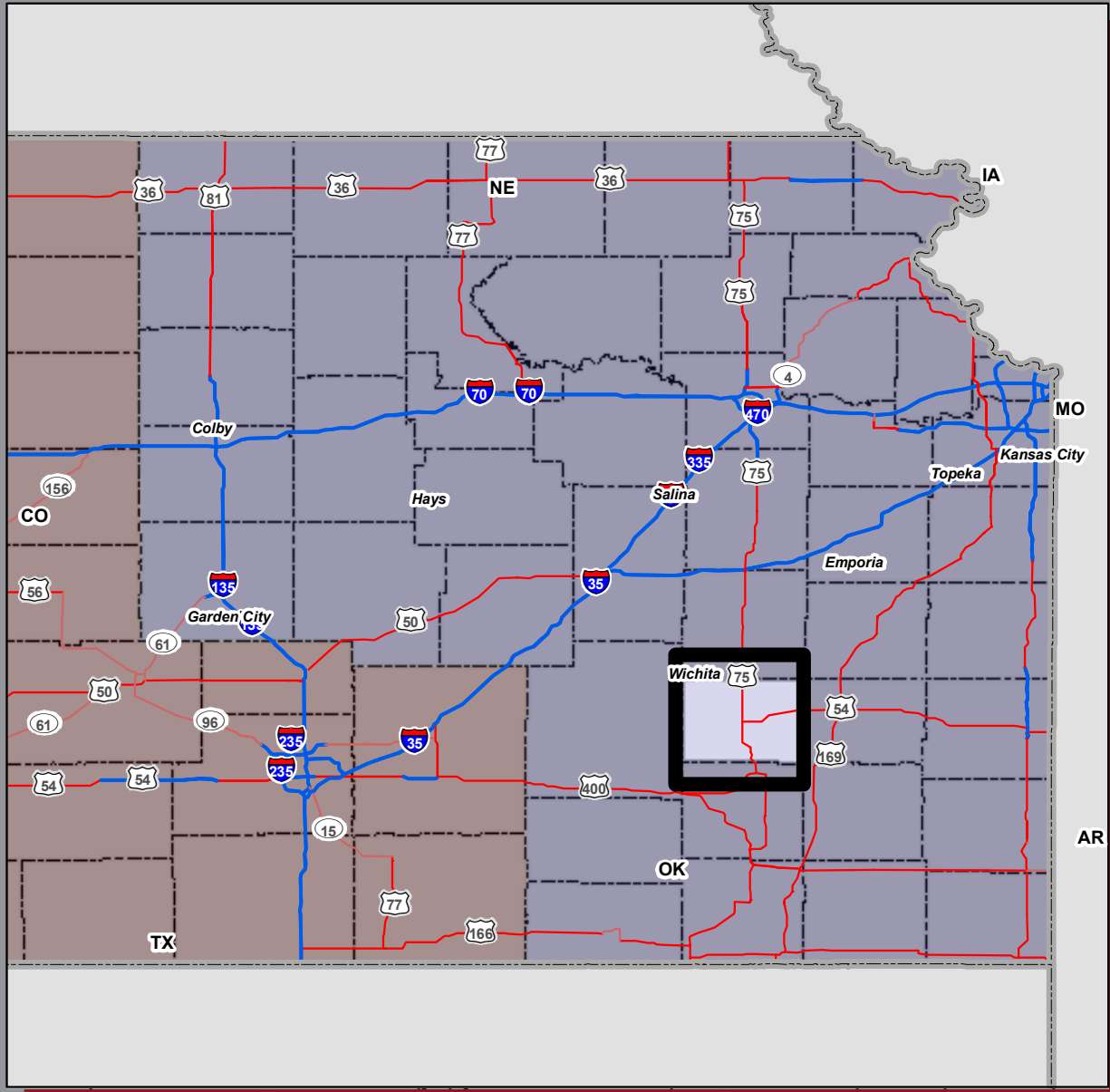
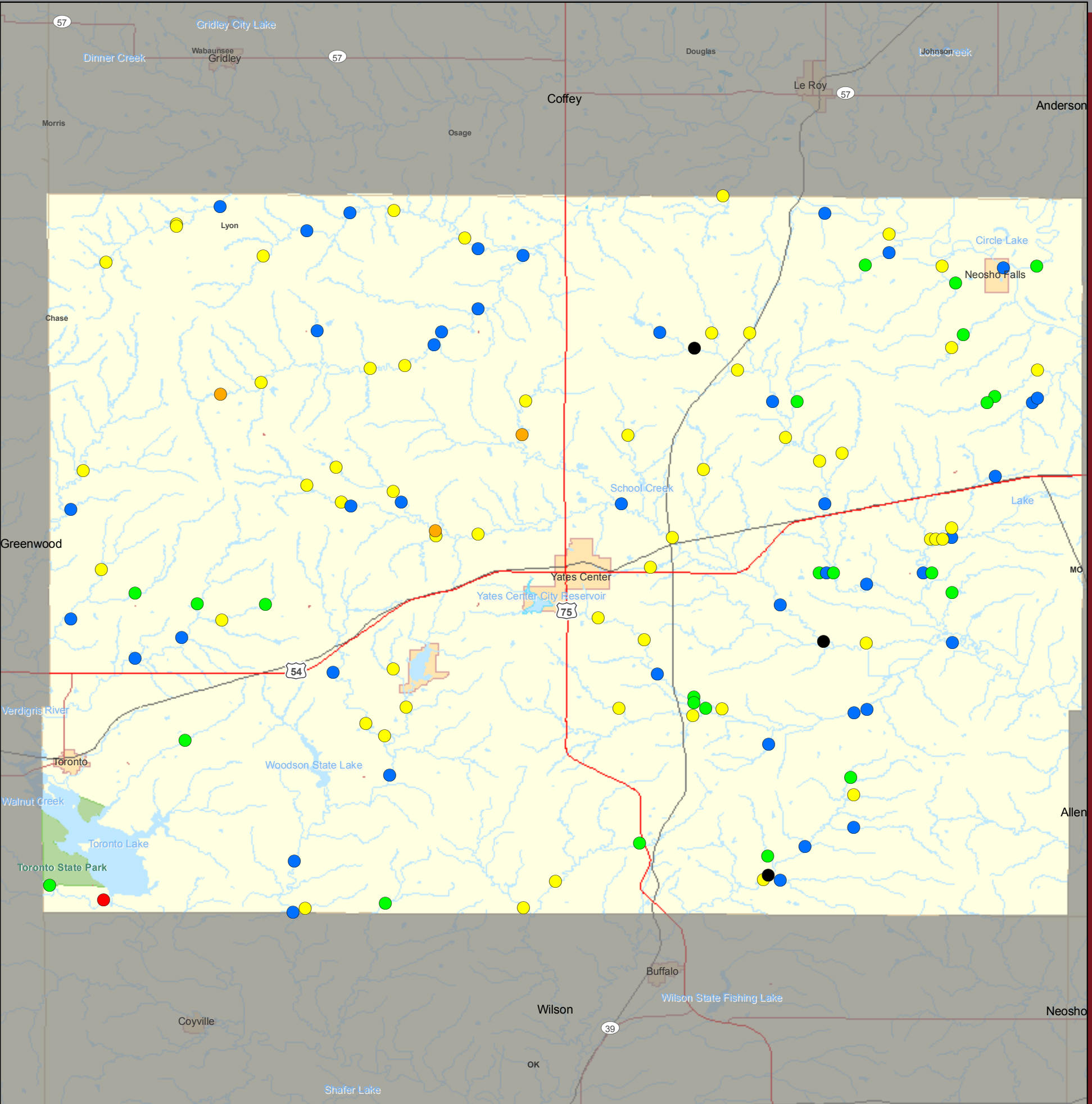

Item 113 Coding

- 1
- 3
- 4
- 5
- 8
- U

- Interstate
- US and State Highways
- Secondary State and County
- Local or rural road
- +++++ Railroads



KDOT Scour Analysis
Item 113 Codes

