

**REMEDIATING EFFECTS OF HUMAN THREATS ON
LOTIC FISH ASSEMBLAGES WITHIN THE MISSOURI
RIVER BASIN: HOW EFFECTIVE ARE CONSERVATION
PRACTICES?**

A Dissertation

presented to

the Faculty of the Graduate School
at the University of Missouri-Columbia

In Partial Fulfillment

of the Requirements for the Degree

Doctor of Philosophy

by

JEFFREY D FORE

Drs. Scott P Sowa and David L Galat, Dissertation Supervisors

JULY 2012

The undersigned, appointed by the dean of the Graduate School, have examined the dissertation entitled

REMIEDIATING EFFECTS OF HUMAN THREATS ON LOTIC FISH ASSEMBLAGES
WITHIN THE MISSOURI RIVER BASIN: HOW EFFECTIVE ARE CONSERVATION
PRACTICES?

presented by Jeffrey Fore,

a candidate for the degree of doctor of philosophy,

and hereby certify that, in their opinion, it is worthy of acceptance.

Dr. Scott P Sowa

Dr. David L Galat

Dr. David D Diamond

Dr. Charles F Rabeni

Dr. Michael A Urban

ACKNOWLEDGEMENTS

Many individuals have contributed to this work and to my development as a scientist. I am deeply indebted to them and cannot thank them enough for their support. My co-advisors, Drs. Scott Sowa and David Galat were a wonderful source of inspiration and knowledge. Dr. Scott Sowa has provided constant encouragement, many thoughtful discussions, and patience throughout this process. His enthusiasm was quite infectious and made this project a joy to complete. Dr. David Galat allowed me the freedom to conduct this research and provided invaluable guidance throughout this project. David's perspective on science and its ability to influence policy has improved my ability to make science relevant to conservation; I hope this influence is evident in my work. Also, thanks for the firewood, David; the winters would have been much colder. Scott and David provided the necessary criticism and patience that allowed me to improve my writing skills. I would like to thank my committee members Drs. David Diamond, Charles Rabeni, and Mike Urban for their guidance, opinions, and encouragement.

This project could not have been accomplished without the assistance from the staff of Missouri Resource Assessment Partnership. Gust Annis and Aaron Garringer handled the majority of the GIS work in this project – thanks guys, I would have been in over my head. Mike Morey's assistance with database management no doubt saved me hours of frustration. Thanks to Tammy Martin, Niki Fuemmeler, and Karen Decker for making the administrative aspects of this project easy.

I would like to thank Charles Rewa and the US Department of Agriculture's Natural Resource Conservation Service for funding this project. George and Susan Wallace compiled the NRCS conservation practice data. Fish sample data were provided

by Missouri Department of Conservation, Kansas Department of Parks, Wildlife, and Tourism, and the Nebraska Game and Parks. Emmanuel Frimpong and Paul Angermeier provided us access to their FishTraits database.

Graduate school wouldn't be as fun without friends and I was fortunate enough to have developed many friendships here. I was fortunate enough to share an office with Josh Lallaman. Josh was always there for thoughtful advice, plenty of distractions, card games, concerts, brewing assistance, and cookouts. You and Sarah became our family away from home. Nathan Weber, thanks for the hunting and fishing trips at Brickey's (my favorite place in Missouri), the many beers, and their resulting conservations. I enjoyed many Saturday's watching college football with Landon Pierce, Jason Harris, Nick Sievert, and Andy Dinges. Happy hours and beers with folks from the Galat lab and Paukert lab were always entertaining.

Lastly, this work could not have been completed without the support of my family. Without the love and support of my parents, Don and Susan Fore, this work would not have been possible. Dad, I promise to make it back home more often for hunting trips. Mom, we will do our best to get closer to home. To my wife Erin, I cannot thank you enough for your patience and willingness to deal with all the long hours, late nights, and lack of vacations. Your love and support throughout this process has always kept me smiling and I am glad we did this together.

TABLE OF CONTENTS

ACKNOWLEDGEMENTS ii

LIST OF TABLES vii

LIST OF FIGURES xi

ABSTRACT..... 1

Chapter 1 - General Introduction 5

 References..... 13

Chapter 2 - Riverine Threat Indices to Assess Watershed Condition and Identify Primary Management Capacity of Agriculture Natural Resource Management Agencies 18

 Abstract..... 18

 Chapter 2 – Summary of Management Opportunities, Use Limitations, and Improvement Options for Riverine Threat Indices to Assess Watershed Condition and Identify Primary Management Capacity of Agriculture Natural Resource Management Agencies..... 20

 Introduction..... 21

 Methods..... 24

 Study area..... 24

 Geographic Framework 25

 Rationale and General Approach to Threat Index Development..... 26

 Modified Threat Metric Data 29

 Estimated grazing..... 29

 Channelized streams 30

 Impervious surfaces 31

 Population density and population change 31

 Quantifying Threat Prevalence 32

 Threat Metric and Index Calculations..... 32

 Example of coupling threat and ecological condition assessments 34

 Results..... 35

 Discussion..... 37

 References..... 42

Chapter 3 - Effectiveness of NRCS Agriculture Conservation Practices on Stream Fish Assemblages 62

 Abstract..... 62

Chapter 3 - Summary of Management Opportunities, Use Limitations, and Improvement Options for Analyses Used to Assess Effectiveness of NRCS Agriculture Conservation Practices on Stream Fish Assemblages	64
Introduction.....	65
Human Threats and Their Influence on Fish Guild Abundance	68
Fishes as Ecological Indicators	69
Study area.....	71
Methods.....	72
General Modeling Approach.....	72
Regional Applicability of Conservation Practice Assessment.....	73
Using Fish and Ecological Guilds to Assess Conservation Practice Effectiveness	74
Modeling Fish Guild Distribution.....	75
Physiography and its Influence on Fish Guild Abundance.....	75
Datasets.....	76
Fish Samples	76
Physiography.....	78
NRCS Conservation Practices	80
Human Threats.....	82
Geographic Framework	82
Specific Modeling Methods.....	83
Fish Guild Distribution Models	83
Conservation Practice Assessment Models	85
Assessing Conservation Practice Effectiveness.....	86
Results.....	88
Fish Guild Distribution Modeling.....	89
Conservation Practice Assessment Modeling.....	90

Assessment of Conservation Practice Effectiveness.....	91
Discussion.....	94
Guild Response to Conservation Practices	94
Limitations and Improving Future Conservation Practice Assessments	97
Conservation Practices Effectiveness	99
References.....	105
Chapter 4 - Framework to Improve Agricultural Conservation Efforts: Reducing Potential Costs and Increasing Ecological Effectiveness.....	150
Abstract.....	150
Chapter 4 - Summary of Management Opportunities, Use Limitations, and Improvement Options for Framework to Improve Agricultural Conservation Efforts: Reducing Potential Costs and Increasing Ecological Effectiveness	152
Introduction.....	153
Allocate conservation resources to watersheds exhibiting ecological degradation	158
Increase the likelihood conservation practices are effective.....	159
Make best use of conservation funding	159
Methods.....	160
Study Area	160
General Methods.....	161
Allocate conservation resources to watersheds exhibiting ecological degradation	
.....	161
Increase the likelihood conservation practices are effective.....	162
Make best use of conservation funding	163
Case Study	165
Results.....	166
Discussion.....	170
References.....	178
VITA.....	208

LIST OF TABLES

Table 2.1. Threat metrics and their data sources used to calculate five threat indices within the Missouri River basin. Abbreviations for the threat indices are AR = Agricultural, UR = Urbanization, PSP = Point-source Pollution, IN = Infrastructure, and NAG = Non-agricultural. 48

Table 2.2. Scoring matrix used to identify stream segments where NRCS had primary management capacity (see text for explanation) in the Missouri River basin. Stream segments that had scores ≥ 2 were considered to be under the primary management capacity of NRCS. Values in parentheses represent threat index scores. 52

Table 2.3. Mean and standard error of threat index values for the Missouri River basin calculated within Bailey’s (1983) divisions. One-way analysis of variance was conducted to determine if means significantly differed by division. Superscripts of different letters indicate a significant difference in mean threat index scores among the ecoregions (row comparisons only). Refer to Fig. 2.2 for map of divisions. 53

Table 2.4. Fish Index of Biotic Integrity (IBI) and threat index scores from four stream sites in Missouri River basin. Higher IBI scores indicate higher biotic integrity. Higher threat index scores indicate higher threat prevalence. 54

Table 2.5. Fish Index of Biotic Integrity (IBI) and metric scores for four streams in the Missouri River basin. Higher IBI and metric scores indicate higher biotic integrity. NAT = native species, NAF = native families, IND = native individuals, SENS = sensitive species, TOL = tolerant species, BNTH = benthic species, SUN = native sunfish species, MIN = minnow species, LOL = long-lived species, INT = introduced species, TRO = trophic strategies, NAC = native carnivore species, NOH = native omnivore and herbivore species, and REP = reproductive strategies. 55

Table 3.1. Variable loadings from categorical principal component analysis of all streams <500 link magnitude in Hot Continental Division of the Missouri River basin. The measurement scale for all variables was percent of a variable in a stream segment’s watershed. Variables were discretized into 10 ordinal categories. Loadings in bold were considered representative of the corresponding principal component. 120

Table 3.2. Variable loadings from categorical principal component analysis of all streams in Prairie Division of the Missouri River basin. The measurement scale for all variables was percent of a variable in a stream segment’s watershed. Variables were discretized into 10 ordinal categories. Loadings in bold were considered representative of the corresponding principal component. 121

Table 3.3. NRCS conservation practices applied between 1999 and 2009 in the Missouri River basin that were included for assessment of conservation practice effectiveness. Practices group codes are soil disturbance (SD) and sediment entering stream channel (SEC). SD practices are designed to reduce or prevent soil erosion and SEC practices prevent eroded sediment from entering stream channels. There are two groups of SEC

practices, and they differ by their measurement unit, SEC-ha are applied by area and SEC-m are applied linearly. The NRCS practice names, codes, and definitions are from the national NRCS practice standards..... 122

Table 3.4. Classification table for lithophil guild presence/absence model in the Prairie Division of the Missouri River basin. Model was developed using classification trees. Split-sample validation was used to assess model accuracy. Approximately 75% of the data were used in the training dataset to parameterize the model, and the remaining data were used as the test dataset..... 128

Table 3.5 Candidate multiple-regression models used to predict lithophil guild abundance in Hot Continental Division of the Missouri River basin. Akaike’s Information Criterion (AIC) values, change in AIC values (ΔAIC), and model weights (ω_i) were used to select candidate models for further evaluation. These models excluded outliers (guild abundance = 0 or > 0.55). Practices group codes are soil disturbance (SD) and sediment entering stream channel (SEC). SD practices are designed to reduce or prevent soil erosion and SEC practices prevent eroded sediment from entering stream channels. Squared variables represent quadratic effects..... 129

Table 3.6. Final model and model-averaged parameter estimates used to predict guild abundance of lithophilous spawners in the Hot Continental Division of the Missouri River basin. Prefix Log10 indicates variable was transformed using \log_{10} , ARC indicates Arcsine transformation, and SQRT indicates square root transformation..... 131

Table 3.7. Candidate multiple-regression models used to predict omnivore guild abundance in Hot Continental Division of the Missouri River basin. Akaike’s Information Criterion (AIC) values, change in AIC values (ΔAIC), and model weights (ω_i) were used to select candidate models for further evaluation. Practices group codes are soil disturbance (SD) and sediment entering stream channel (SEC). SD practices are designed to reduce or prevent soil erosion and SEC practices prevent eroded sediment from entering stream channels. Squared variables represent quadratic effects. 132

Table 3.8. Final model and model-averaged parameter estimates used to predict guild abundance of omnivores in the Hot Continental Division of the Missouri River basin. Prefix Log10 indicates variable was transformed using \log_{10} , ARC indicates Arcsine transformation, and SQRT indicates square root transformation. 134

Table 3.9. Candidate multiple-regression models used to predict lithophilous spawner guild abundance in Prairie Division of the Missouri River basin. Akaike’s Information Criterion (AIC) values, change in AIC values (ΔAIC), and model weights (ω_i) were used to select candidate models for further evaluation. Practices group codes are soil disturbance (SD) and sediment entering stream channel (SEC). SD practices are designed to reduce or prevent soil erosion and SEC practices prevent eroded sediment from entering stream channels. There are two groups of SEC practices, and they differ by their measurement unit, SEC-ha are applied by area and SEC-m are applied linearly. Squared variables represent quadratic effects..... 135

Table 3.10. Final model and model-averaged parameter estimates used to predict guild abundance of lithophilous spawners in the Hot Continental Division of the Missouri River basin. Prefix Log10 indicates variable was transformed using \log_{10} , and ARC indicates Arcsine transformation, and SQRT indicates square root transformation..... 137

Table 3.11. Criteria used to classify stream segments in Missouri River basin into conservation practice effectiveness groups. BCA = base condition abundance and assumes no conservation practices were implemented. RCA = reference condition abundance and was used to classify streams as ‘more’ or ‘less’ disturbed. Reference condition abundance was calculated as mean guild abundance from fish samples in ‘less’ disturbed stream segments. CCA = conservation condition abundance and accounts for the effects of currently implemented conservation practices..... 138

Table 3.12. Mean values for each conservation practice effectiveness group of predicted lithophil guild abundance scenarios and NRCS conservation practices in Hot Continental Division of the Missouri River basin. Mean values within rows that have different subscripts are significantly different at $\alpha = 0.05$ using T-tests and Bonferroni corrections. Standard error is in parentheses. 139

Table 3.13. Mean values for each conservation practice effectiveness group of predicted omnivore guild abundance scenarios and NRCS conservation practices in Hot Continental Division of the Missouri River basin. Mean values within rows that have different subscripts are significantly different at $\alpha = 0.05$ using T-tests and Bonferroni corrections. Standard error is in parentheses. 140

Table 3.14. Mean values for each conservation practice effectiveness group of predicted lithophil guild abundance scenarios and NRCS conservation practices in Prairie Division of the Missouri River basin. Mean values within rows that have different subscripts are significantly different at $\alpha = 0.05$ using T-tests and Bonferroni corrections. Standard error is in parentheses. 141

Table 4.1. Key variables, their source, and method of computation as used in each step of the decision support framework as presented in the Missouri River basin case study. Detailed methodology for each variable can be found in the citations provided..... 184

Table 4.2. Key variables and their descriptions used in the multiple-regression model that predicted lithophil guild abundance. Human threat indices were used as inputs to the multiple-regression model and were used to calculate NRCS primary management capacity and the variables that compose each index are listed. 186

Table 4.3. Conservation practices, their NRCS practice code, and their definitions that made up each conservation practice scenario used in the decision support framework for the Missouri River basin. The first scenario is made up of conservation practices designed 1) to reduce soil disturbance and prevent soil erosion, and the other scenario is made up of conservation practices designed 2) to reduce sedimentation by preventing eroded materials from entering stream channels. 187

Table 4.4. Cost of individual conservation practices and conservation practice scenarios by ecoregion. The individual conservation practice costs are represented as the mean cost per square kilometer among the states of Nebraska, Missouri, Kansas, South Dakota, and North Dakota. Scenario costs were estimated by multiplying the “practice percentage by ecoregion” field with each practices’ mean cost and summing the respective practice costs. Practices in the reduce soil disturbance scenario are designed to prevent erosion and practices in the reduce sedimentation scenario prevent sediment from entering stream channels. The ecoregion abbreviations are HCD = Hot Continental Division and PD = Prairie Division. 189

Table 4.5. Summary statistics of total cost estimates for conservation and the percentiles of cost-benefit ratio for the different conservation practice scenarios by ecoregion. The cost-benefit ratio values are expressed as the cost (\$USD) of increasing lithophil guild abundance by units of 0.01 and the percentiles were calculated within each ecoregion. The reduce disturbance and sedimentation scenario assumes equal proportions of both practice scenarios were implemented in a watershed and their effects to lithophil abundance were summed. 191

Table 4.6. Percentiles of cost-benefit ratio for each conservation practice scenario for the entire assessment region, irrespective of ecoregion. The cost-benefit ratio values are expressed as the cost (\$USD) of increasing lithophil guild abundance by 0.01 units and the percentiles were calculated within each ecoregion. 192

LIST OF FIGURES

- Figure 2.1. Conceptual diagram illustrating potential decision pathways and outcomes of conducting ecological condition and threat assessments. Solid arrows represent the alternative decision paths resource managers could follow when conducting each assessment independent of the other. Dotted arrows and borders represent decision pathways and potential assessment outcomes when ecological condition and threat assessments are coupled. Italic font represents intermediate outcomes of the decision path (e.g., lithophils were identified as limiting biotic integrity in the ecological condition assessment). 56
- Figure 2.2. Map of the Missouri River basin and Bailey’s (1983) division classifications. 57
- Figure 2.3. Map depicting four stream sites within the Missouri River basin where fish index of biotic integrity scores were computed. Numbers on map depict site numbers that are referenced in text. Refer to Tables 2.4 for index of biotic integrity scores and Table 2.5 for individual IBI metric scores. 58
- Figure 2.4. Map of the agriculture threat index scores (target threats) for every stream segment within the US portion of the Missouri River basin. Threat index scores were calculated using threat prevalence information quantified for every stream segment’s upstream watershed area. Threat index scores were calculated separately for each division classification (see Figure 2.2). Maximum threat scores are relative to the most threatened stream segment in each division..... 59
- Figure 2.5. Map of the non-agriculture threat index scores (non-target threats) for every stream segment within the US portion of the Missouri River basin. Threat index scores were calculated using threat prevalence information quantified for every stream segment’s upstream watershed area. Threat index scores were calculated separately for each division classification (see Figure 2.2). Maximum threat scores are relative to the most threatened stream segment in each division. 60
- Figure 2.6. Map of NRCS primary management capacity for every stream segment within the US portion of the Missouri River basin. Streams with management capacity scores ≥ 2 (see text and Table 2.2) were considered to be under NRCS management capacity. 61
- Figure 3.1. Map of Missouri River basin and Bailey’s Division that were used as an ecoregion classification..... 142
- Figure 3.3. Expected change in guild abundance per unit increase of conservation practices. SEC = conservation practices designed to reduce sediment entering stream channels that were applied in hectares. SEC-m = conservation practices designed to reduce sediment entering stream channels that were applied in meters. SD = conservation practices designed to reduce soil disturbance and applied in hectares. Plots were developed by using each conservation practice’s parameter estimates from its respective

assessment model (Tables 3.6, 3.8, and 3.10) and excluded the effects of all other parameters. All effects in Hot Continental Division (HCD) are quadratics and those in Prairie Division (PD) are linear. The scale for SEC-m practices is 10 times the value shown and the units are m/km². 145

Figure 3.4. Map of stream segments <500 link magnitude classified into predicted conservation practice effectiveness groups in the Prairie and Hot Continental Divisions of the Missouri River basin. Lithophilous spawners were used as an indicator. Refer to Table 3.11 for criteria used to delineate conservation practice effectiveness groups. NA refers to streams too large for assessment (link magnitude >500). 146

Figure 3.5. Predicted percent change in lithophil guild abundance from base condition abundance to conservation condition abundance for stream segments with link magnitude <500 in the Prairie and Hot Continental Division of the Missouri River basin. Base condition abundance was predicted assuming no conservation practices were applied on the landscape and conservation condition abundance accounted for the effects of currently applied NRCS soil conservation practices. Positive values indicate positive conservation practice effects because lithophil abundance was expected to increase with conservation practice density. 147

Figure 3.6. Map of stream segments in stream segments <500 link magnitude classified into predicted conservation practice effectiveness groups in the Prairie and Hot Continental Divisions of the Missouri River basin. Omnivores were used as an indicator. Refer to Table 3.11 for criteria used to delineate conservation practice effectiveness groups. NA refers to streams too large for assessment (link magnitude >500). 148

Figure 3.7. Predicted percent change in lithophil guild abundance from base condition abundance to conservation condition abundance for stream segments with link magnitude <500 in the Prairie and Hot Continental Division of the Missouri River basin. Base condition abundance was predicted assuming no conservation practices were applied on the landscape and conservation condition abundance accounted for the effects of currently applied NRCS soil conservation practices. Negative values indicate positive conservation practice effects because omnivore abundance was expected to decline in response to conservation practice density. 149

Figure 4.1. Flow diagram depicting the process of the decision support framework to prioritize and select watersheds for agricultural conservation. The leftmost diagram represents the three major components of the decision framework and the size of the boxes signifies the winnowing process of selecting watersheds. The remaining diagram represents the key components, major decision points, and outcome (boxes in bold) for each step of the framework. See Fore (chap. 3) for detailed methodology on Step 1 and Fore (Chap. 2) for details on Step 2. 193

Figure 4.2. Map of Missouri River basin showing Bailey’s Divisions that were used as an ecoregion classification. The case study was conducted in the Hot Continental Division and the Prairie Division. 194

Figure 4.3. Flow diagram depicting the process of determining watersheds that were ecologically degraded (step 1 of Fig. 4.1). Dashed boxes represent key variables used to classify watersheds as ecologically degraded. The bold box represents the major output from this step. Refer to Table 4.1 for descriptions of the key variables and multiple-regression model used in this process. Refer to Table 4.2 for description of key inputs to the multiple-regression model used in this process. 195

Figure 4.4. Flow diagram depicting the process of determining watersheds where NRCS had primary management capacity (step 2 of Fig. 4.1). Dashed boxes represent key variables used to determine NRCS primary management capacity. The bold box represents the major output from this step. Refer to Table 4.1 for descriptions of the threat indices used in this process. Refer to Table 4.2 for description of key inputs to the threat indices used in this process. 196

Figure 4.5. Flow diagram depicting the process of determining total conservation cost and cost-benefit ratio for each watersheds in the study area (step 3 of Fig. 4.1). Dashed boxes represent the three key variables used to estimate total conservation cost for each watershed. The bold box represents the major outputs from this step. Refer to Table 4.1 for descriptions of the outputs from this process. 197

Figure 4.6. Map of predicted increase in lithophil abundance needed to shift watershed (as represented by stream segments) condition from ‘more’ disturbed to reference condition for all stream segments <500 link magnitude in Hot Continental and Prairie Divisions of the Missouri River basin. The abundance increase was estimated from models developed by Fore (Chap. 3). 198

Figure 4.7. Map depicting total watershed conservation cost of improving fish assemblage condition from more disturbed to reference condition in stream segments in Hot Continental and Prairie Divisions of the Missouri River basin <500 link magnitude using the reduce soil disturbance conservation practice scenario. 199

Figure 4.8. Map depicting total watershed conservation cost of improving fish assemblage condition from more disturbed to reference condition in stream segments in Hot Continental and Prairie Divisions of the Missouri River basin <500 link magnitude using the reduce sedimentation conservation practice scenario. 200

Figure 4.9. Map depicting total watershed conservation cost of improving fish assemblage condition from more disturbed to reference condition in stream segments in Hot Continental and Prairie Divisions of the Missouri River basin <500 link magnitude using the reduce disturbance and sedimentation conservation practice scenario. 201

Figure 4.10. Map depicting watershed percentiles of the cost-benefit ratio in stream segments in Hot Continental and Prairie Divisions of the Missouri River basin <500 link magnitude for the reduce soil disturbance scenario. The percentiles were calculated across both the Hot Continental and Prairie Division. Refer Table 4.4 for the percentile values. 202

Figure 4.11. Map depicting watershed percentiles in stream segments in Hot Continental and Prairie Divisions of the Missouri River basin <500 link magnitude of the cost-benefit ratio for the reduce sedimentation scenario. The percentiles were calculated across both the Hot Continental and Prairie Division. Refer to Table 4.4 for the percentile values. 203

Figure 4.12. Map depicting watershed percentiles of the cost-benefit ratio in stream segments in Hot Continental and Prairie Divisions of the Missouri River basin <500 link magnitude for the reduce disturbance and sedimentation scenario. The percentiles were calculated across both the Hot Continental and Prairie Division. Refer to Table 4.4 for the percentile values..... 204

Figure 4.13. Map depicting watershed percentiles of the cost-benefit ratio in stream segments in Hot Continental and Prairie Divisions of the Missouri River basin <500 link magnitude for the reduce soil disturbance scenario. The percentiles were calculated separately for the Hot Continental Division and Prairie Division. Refer to Table 4.3 for the percentile values..... 205

Figure 4.14. Map depicting watershed percentiles of the cost-benefit ratio in stream segments in Hot Continental and Prairie Divisions of the Missouri River basin <500 link magnitude for the reduce sedimentation scenario. The percentiles were calculated separately for the Hot Continental Division and Prairie Division. Refer to Table 4.3 for the percentile values..... 206

Figure 4.15. Map depicting watershed percentiles of the cost-benefit ratio in stream segments in Hot Continental and Prairie Divisions of the Missouri River basin <500 link magnitude for the reduce disturbance and sedimentation scenario. The percentiles were calculated separately for the Hot Continental Division and Prairie Division. Refer to Table 4.3 for the percentile values..... 207

REMEDIATING EFFECTS OF HUMAN THREATS ON LOTIC FISH ASSEMBLAGES WITHIN THE MISSOURI RIVER BASIN: HOW EFFECTIVE ARE CONSERVATION PRACTICES?

Jeffrey D Fore

Drs. Scott P Sowa and David L Galat, Dissertation Supervisors

ABSTRACT

Agricultural commodity production and its resulting sedimentation stressors pose the largest threat to lotic systems. Addressing agricultural threats will require strategic allocation of conservation resources and cooperation with private agricultural producers to identify ecologically degraded streams and to determine the appropriate place, type, and amount of conservation practices (CPs) needed to improve ecological conditions. The goal of this research was to develop tools agricultural conservation managers can use to reduce stream sedimentation and improve the allocation of limited conservation resources in a manner that results in improved water quality and ecological condition. Developing tools to address three major information needs can improve agricultural conservation, they are: 1) assessing total watershed conditions and .determining stream segments where agricultural CPs are likely to be effective by conducting threat assessments, 2) assessing the effectiveness of agricultural CPs and determining where current conservation has been successful and future conservation efforts are needed, and 3) making strategic conservation decisions by using a decision support framework to understanding the amount and costs of CPs required to meet ecological objectives.

Total watershed condition for every stream segment in the Missouri River basin was summarized by conducting a threat assessment and developing a suite of human threat indices from 17 threat metrics for managers to select and prioritize watersheds to implement agricultural CPs. Agricultural threats were most prevalent across the Missouri River basin, but considerable heterogeneity of non-agricultural threats existed within the basin and in regions of high agricultural prevalence. Management capacity was identified for every stream segment and used to identify streams where US Department of Agriculture's Natural Resources Conservation Service (NRCS) conservation practices were most likely to be effective because the prevalence of agricultural threats was greater than non-agricultural threats.

Understanding the effects of applied NRCS CPs on fish assemblages will allow managers to maximize environmental benefits and ensure conservation funding is properly allocated. The response of lithophil and omnivore guild abundance of lotic fishes to multiple NRCS soil CPs was predicted using multiple-regression models to assess the effectiveness of CPs designed to reduce soil disturbance and sediments from entering stream channels. The relationships among NRCS CPs and omnivore and lithophil guild abundances indicated that NRCS soil CPs have the potential to reduce agricultural sources of stream sedimentation and improve ecological condition. I evaluated the effectiveness of NRCS soil CPs for individual stream segments by determining if 'more' disturbed streams were predicted to shift to 'less' disturbed conditions as a function of the association among fish guilds and applied CPs. Conservation practices were predicted to effectively shift 2% of the streams we evaluated from 'more' to 'less' disturbed conditions. The low number of watersheds where NRCS

CPs were predicted to be effective was primarily due to low densities of CPs in watersheds, but the models suggested effectiveness could be improved by applying CPs in at least 50% of a watershed's land area.

Improving conservation outcomes in streams via application of CPs will require strategically allocating conservation resources (primarily funding) in a manner that ensures CPs are implemented in high enough densities to meet desired conservation goals. I integrated the results from the threat and CP assessments into a decision support framework designed to improve the allocation of conservation resources and to increase the ecological effectiveness of agricultural CPs on private lands. The framework used a winnowing process to identify watersheds where ecological degradation has occurred, where CPs were likely to be effective, and where the total conservation cost and cost-benefit ratio (cost per unit increase in guild abundance) of applying CPs were lowest. A case study in portions of the Missouri River basin was conducted and I identified and estimated total conservation costs and cost-benefit ratios in 2,633 ecologically degraded watersheds where agricultural CPs were likely to be effective (i.e., the watersheds needed agricultural conservation and NRCS had primary management capacity). Conservation practices designed to prevent soil disturbance were generally more cost effective than CPs designed to prevent sediment from entering stream channels. Total conservation costs and cost-benefit ratios differed substantially between the Hot Continental Division and Prairie Division ecoregions due to relative differences in the estimated amount of conservation needed.

The threat indices developed in this research are advantageous over traditional landcover maps because they summarize total watershed conditions for individual stream

segments and allow managers to evaluate where an agency has primary management capacity. The threat indices can be incorporated into decision support frameworks to prioritize regions and specific watersheds to conduct conservation efforts, and they can be coupled with assessments of ecological condition to identify likely stressors causing ecological degradation. The assessment of conservation practice effectiveness provides managers with estimates of ecological degradation for individual stream segments and allows managers to determine where applied CPs have improved fish assemblage condition, where current CPs can maintain ecological conditions, and where future conservation efforts are needed. The models developed to predict fish guild abundance also provided estimates of the type and amount of CPs that could be implemented in watersheds of individual stream segments so managers can estimate the total cost and cost-benefit ratio of applying CPs to meet ecological objectives. Incorporating the above elements into a decision support framework allows managers to make best use of conservation resources because they can strategically identify and select stream segments to apply CPs. Managers can improve CP adoption rates and fish assemblage condition by strategically focusing conservation efforts in specific stream segments and allocating the proper amount of funding for voluntarily applied CPs that are cost-shared with private producers.

CHAPTER 1 - GENERAL INTRODUCTION

Anthropogenic activities have negatively affected lotic ecosystems throughout the USA. Nearly half (42%) of the wadeable streams in the USA are considered to have 'poor' biotic integrity because of pollution and sedimentation. Meanwhile, only 28% are considered to have 'good' biotic integrity (US Environmental Protection Agency 2006). Threats to freshwater biodiversity have primarily been driven by intensive large-scale agriculture production (McLaughlin and Mineau 1995) and human modification of the landscape (Allan 2004; Harding and others 1998), and as a result, native freshwater fishes have experienced large declines in abundance and are now one of the most threatened groups of vertebrates (Ricciardi and Rasmussen 1999). Nutrient pollution and sedimentation are considered the major stressors causing degradation of wadeable lotic systems (U.S. Environmental Protection Agency 2000; US Environmental Protection Agency 2006; Waters 1995).

Agricultural commodity production (e.g., row crops and livestock) is generally regarded as the largest threat to freshwaters and lotic systems due to its prevalence (McLaughlin and Mineau 1995). About 46% of the USA is under agricultural production (pasture, grazing, or crops; Lubowski and others 2006), and many federal lands are leased for livestock grazing. For example, the U.S. Bureau of Land Management manages livestock grazing on over 63 million hectares of public land (about the size of Texas). Large-scale agricultural production results in many ecological stressors to lotic systems.

Stream sedimentation is regarded as the largest stressor to lotic systems in the USA because of its impact on physical habitats and its direct effects to biota (U.S.Environmental Protection Agency 2000; Waters 1995; Wood and Armitage 1997). The primary cause of stream sedimentation in the Midwestern USA is poor agricultural practices (e.g., clean tillage or overgrazing) that result in excessive soil disturbance and soil erosion. Sedimentation from agriculture decreases channel and bank stability (Diana and others 2006; Infante and others 2006), leads to greater bank erosion and channel widening (Kondolf and others 2002), and increases suspended sediment loading (Zimmerman and others 2003). These changes in water quality and physical habitat are capable of causing direct mortality to fishes (Zimmerman and others 2003) or altering the trophic and reproductive structure of fish assemblages (Berkman and Rabeni 1987; Sutherland and others 2002).

Agricultural production occurs primarily on private lands and their management will be critical to the success of agricultural conservation (Knight 1999; Norton 2000). Large-scale private land conservation was significantly bolstered in the USA with passage of the 1985 Farm Bill that authorized billions of dollars (USD\$17 billion in 2002) for soil conservation (Gray and Teels 2006). The Farm Bill originally set out to reduce soil erosion from highly erodible fields and attempted to limit excess food production by idling marginal croplands (Heard and others 2000). The Farm Bill has since evolved to administer conservation programs (e.g., Wetlands Reserve Program and Environmental Quality Incentives Program) through the U.S. Department of Agriculture's Natural Resources Conservation Service (NRCS) that are intended to improve wildlife habitat and environmental conditions (e.g., improved water quality) in

agricultural landscapes (Burger and others 2006; Gray and Teels 2006; Heard and others 2000).

NRCS provides technical and cost-share assistance to private agricultural producers who voluntarily implement conservation practices (CPs) intended to provide environmental benefits (e.g., improve water quality or wildlife habitats). Commonly implemented CPs address wildlife habitat (e.g., reestablishing native vegetation or wetlands) and soil erosion and water quality issues that result from crop production and grazing. Though NRCS CPs address issues such as nutrient and pesticide runoff, the focus of this study is on CPs designed to prevent sedimentation.

The potential effects of agricultural CPs are generally well understood from an agronomic (e.g., soil quality and effects on commodity yields; Schnepf and Cox 2006) and terrestrial wildlife perspective (Haufler 2007), but there is a lack of understanding of how agricultural CPs affect biota in lotic systems. Removing land from production and planting perennial vegetation can nearly eliminate soil erosion and reduces excessive runoff (Gilley and others 1997). Watersheds predominantly under no-till production contribute 6 – 10 times less sediment than conventionally tilled watersheds (Matisoff and others 2002). Over-grazing can increase soil erosion and alters hydrology (Belsky and others 1999; Trimble and Mendel 1995), but these problems can be avoided or greatly reduced by adjusting stocking rates and excluding grazers from riparian zones (Meehan and Platts 1978; Platts 1989). Installing grass buffers around field borders, using filter strips, and restoring riparian zones can decrease sediment concentrations in runoff and reduce bank erosion (Burckhardt and Todd 1998; Dosskey and others 2005; Dosskey and others 2002; Tingle and others 1998). Lands enrolled in the Conservation Reserve

Program to reestablish grassland habitats had increased grassland bird nest success and waterfowl have benefitted from wetland restoration (Heard and others 2000). Westra and others (2004) found mixed results when evaluating Conservation Reserve Program effectiveness at reducing sediment loading that caused lethal fish events. Agricultural CPs that address soil erosion and riparian habitats have been shown to positively affect instream habitats and fish communities (Wang and others 2002). However, there have been no studies documenting fish assemblage response to multiple CPs over large geographies.

Understanding the effects of NRCS CPs on fish assemblages will allow managers to maximize environmental benefits and ensure conservation funding is properly allocated. A better understanding of how fish assemblages respond to currently implemented CPs would allow resource managers to improve decision-making regarding the type and density of CPs needed to improve agricultural conservation efforts. By strategically identifying ecologically degraded watersheds and estimating the types and amount of CPs needed for conservation, managers will be able to utilize limited conservation resources, primarily funding, in a manner that saves money and maximizes environmental benefits.

Addressing several key information needs can increase the ecological effectiveness of conservation efforts. First, threat assessments can be useful tools for assessing watershed condition and identifying stream segments where NRCS has primary management capacity; i.e., stream segments where NRCS CPs are more likely to be effective because agricultural threats are more prevalent than non-agricultural threats. Identifying NRCS management capacity helps managers ensure that the effects of the

CPs they implement are not negated by non-agricultural threats contributing additional sources of ecological stress. Second, assessing the effects of NRCS soil CPs on fish assemblages will provide managers the information needed to determine the type and density of CPs most effective at remediating stream sedimentation issues. Third, managers can use these assessments to identify sources of ecological degradation in watersheds and identify stream segments where current agricultural conservation has improved fish assemblages to a reference condition. If managers can identify watersheds in need of conservation and estimate the density and type of CPs needed to meet conservation goals they could also benefit from understanding the cost of implementing CPs because conservation funding is always a limiting factor. Although understanding these three major components (i.e., NRCS management capacity, CP effects, and conservation costs) alone could improve agricultural conservation, decision makers could more effectively use the information if it were incorporated into a decision framework designed to strategically allocate funding for agricultural conservation.

The goal of this research was to develop tools agricultural conservation managers can use to reduce stream sedimentation and improve the allocation of limited conservation resources in a manner that results in improved water quality and ecological condition. Each chapter was written independently to stand-alone and, accordingly, has its own specific goals and objectives that resulted in some overlap of introductory material. A bulleted one-page summary follows the abstract of each chapter and describes potential management opportunities, use limitations, caveats, and recommendations to improve the results and tools presented in the chapter.

The goal of Chapter 2 was to develop a suite of threat indices and provide a framework for NRCS and other resource management agencies to select and prioritize watersheds to implement agricultural conservation practices for each of the 450,000+ stream segments in the Missouri River basin.

The specific objectives were to:

- quantify the watershed percentages or densities of seventeen threat metrics that represent major sources of ecological stress to stream communities across the basin
- conduct a threat assessment to assess total watershed condition for each stream segment using five threat indices developed from the threat metrics: agriculture, urban, point-source pollution, infrastructure, and all non-agriculture threats
- identify stream segments where NRCS has primary management capacity (i.e., the threats in a watershed can best be addressed through agricultural conservation practices applied with NRCS assistance).

The goal of Chapter 3 was to determine if NRCS CPs designed to reduce soil erosion or prevent sedimentation in agriculturally degraded streams and small rivers were ecologically effective, and to identify the types of CPs that were most effective. Soil conservation practices were considered ecologically effective in a watershed if their implementation (i.e., their presence and density) was predicted to shift streams from ‘more’ to ‘less’ disturbed conditions because of a presumed reduction in stream

sedimentation as defined by reference condition values of fish guild abundance. This assessment was based on NRCS records of CPs applied from 1998 – 2009.

The goal was accomplished by completing two objectives:

- Assess CP effectiveness in streams and small rivers by using a multiple-regression modeling framework to account for the variation in fish reproductive and trophic guild abundance as a function of physiographic features and human threats.
 - Use the models to estimate how NRCS CPs affect guild abundance.
 - Determine for individual stream segments if currently implemented CPs were predicted to shift streams from ‘more’ to ‘less’ disturbed conditions
- Determine if CPs designed to prevent soil erosion were more effective than those designed to prevent eroded sediment from entering stream channels.

The goal of Chapter 4 was to develop a decision support framework that improves conservation resource allocation and ecological effectiveness of agricultural conservation practices for private lands at regional and watershed spatial scales. A case study in the Missouri River basin was used to illustrate how NRCS could implement this framework to allocate financial resources and agricultural conservation practices to regions and individual streams segments to improve fish assemblage condition.

The chapters are presented in a progressive manner because I incorporated results and tools from one chapter to the subsequent chapter(s). The threat assessment and resulting threat indices that represented total watershed condition for individual stream

segments created in Chapter 2 were important elements in Chapters 3 and 4. The threat indices were used in multiple-regression models to account for the influence of human threats on fish guild abundance so that the effectiveness of NRCS CPs could be evaluated. These models were used to predict whether NRCS CPs shifted individual stream segments from ‘more’ disturbed to reference conditions based on their associations between fish guild abundance and CPs. Individual stream segments that were ecologically degraded and likely in need of agricultural conservation were also identified using the models. Chapter 4 illustrates how the tools and knowledge generated in Chapter 2 and 3 could be incorporated into a decision support framework designed to improve the allocation of conservation resources. The stream segments identified in Chapter 3 as in need of agricultural conservation were used to select an initial subset of stream segments that were ecologically degraded. This subset of streams was further winnowed down by utilizing the threat indices from Chapter 2 to identify stream segments where NRCS had primary management capacity (i.e., stream segments where agricultural threats were more prevalent than non-agricultural threats) and CPs were likely to be effective. From this subset of streams, the models from Chapter 3 were used to estimate the amount of CPs needed to shift individual stream segments classified as ‘more’ disturbed to a reference condition. This allowed total conservation costs and cost-benefit ratios to be computed for each stream segment so that managers can make strategic decisions regarding the allocation of conservation funding to specific regions or stream segments.

References

- Allan JD (2004) Landscapes and Riverscapes: The Influence of Land Use on Stream Ecosystems. *Annual Review of Ecology, Evolution, and Systematics* 35:257-284
- Belsky AJ, Matzke A, Uselman S (1999) Survey of livestock influences on stream and riparian ecosystems in the western United States. *Journal of Soil and Water Conservation* 54:419-431
- Berkman HE, Rabeni CF (1987) Effect of siltation on stream fish communities. *Environmental Biology of Fishes* 18:285-294
- Burckhardt JC, Todd BL (1998) Riparian Forest Effect on Lateral Stream Channel Migration in the Glacial Till Plains. *Journal of the American Water Resources Association* 34:179-184
- Burger Jr. LW, McKenzie D, Thackston R, Demaso SJ (2006) The Role of Farm Policy in Achieving Large-Scale Conservation: Bobwhite and Buffers. *Wildlife Society Bulletin* 34:986-993
- Diana M, Allan JD, and Infante D. The influence of physical habitat and land use on stream fish assemblages in southeastern Michigan. Hughes, Robert M., Wang, Lizhu, and Seelbach, Paul W. *Landscape Influences on Stream Habitats and Biological Assemblages*. 359-374. 2006. Bethesda, Maryland, American Fisheries Society, Symposium 48.
- Dosskey MG, Eisenhauer DE, Helmers MJ (2005) Establishing conservation buffers using precision information. *Journal of Soil and Water Conservation* 60:349-354

- Dosskey MG, Helmers MJ, Eisenhauer DE, Franti TG, Hoagland KD (2002) Assessment of concentrated flow through riparian buffers. *Journal of Soil and Water Conservation* 57:336-343
- Gilley JE, Doran JW, Karlen DL, Kaspar TC (1997) Runoff, erosion, and soil quality characteristics of a former Conservation Reserve Program site. *Journal of Soil and Water Conservation* 52:189-193
- Gray RL, Teels BM (2006) Wildlife and Fish Conservation Through the Farm Bill. *Wildlife Society Bulletin* 34:906-913
- Harding JS, Benfield EF, Bolstad PV, Helfman GS, Jones III EBD (1998) Stream biodiversity: The ghost of land use past. *Proceedings of the National Academy of Sciences of the United States of America* 95:14843-14847
- Haufler, JB (2007) Fish and wildlife response to Farm Bill conservation practices. *The Wildlife Society Technical Review* 07-1, Bethesda, Maryland, USA
- Heard LP, Allen AW, Best LB, Brady SJ, Burger W, Esser AJ, Hackett E, Johnson DH, Pederson RL, Reynolds RE, Rewa C, Ryan M, Molleur R, Buck P (2000) A comprehensive review of Farm Bill contributions to wildlife conservation, 1985 - 2000. Technical Report WHMI-2000, U.S. Department of Agriculture, Natural Resources Conservation Service, Madison, Mississippi, USA
- Infante DM, Wiley MJ, Seelbach PW (2006) Relationships among channel shape, catchment characteristics, and fish in lower Michigan streams. In: Hughes RM, Wang L, Seelbach PW (eds), *Landscape Influences on Stream Habitat and Biological Assemblages*. American Fisheries Society, Bethesda, Maryland, pp 339-357

- Knight RL (1999) Private Lands: The Neglected Geography. *Conservation Biology* 13:223-224
- Kondolf GM, Piégay H, Landon N (2002) Channel response to increased and decreased bedload supply from land use change: contrasts between two catchments. *Geomorphology* 45:35-51
- Lubowski RN, Vesterby M, Bucholtz S, Baez A, Roberts MJ (2006) Major Uses of Land in the United States, 2002. Economic Information Bulletin Number 14, U.S. Department of Agriculture, Economic Research Service, 47 pp
- Matisoff G, Bonniwell EC, Whiting PJ (2002) Soil Erosion and Sediment Sources in an Ohio Watershed using Beryllium-7, Cesium-137, and Lead-210. *Journal of Environmental Quality* 31:54-61
- McLaughlin A, Mineau P (1995) The impact of agricultural practices on biodiversity. *Agriculture, Ecosystems & Environment* 55:201-212
- Meehan WR, Platts WS (1978) Livestock grazing and the aquatic environment. *Journal of Soil and Water Conservation* 33:274-278
- Norton DA (2000) Editorial: Conservation Biology and Private Land: Shifting the Focus. *Conservation Biology* 14:1221-1223
- Platts WS (1989) Compatibility of livestock grazing strategies with fisheries. In: Gresswell RE, Barton BA, Kershner JL (eds), *Practical approaches to riparian resource management: an education workshop*. U.S. Bureau of Land Management, Billings, MT, pp 103-110
- Ricciardi A, Rasmussen JB (1999) Extinction Rates of North American Freshwater Fauna. *Conservation Biology* 13:1220-1222

- Schnepf M, Cox CA (2006) Environmental benefits of conservation on cropland: The status of our knowledge. Soil and Water Conservation Society, Ankeny, IA, 326 pp
- Sutherland AB, Meyer JL, Gardiner EP (2002) Effects of land cover on sediment regime and fish assemblage structure in four southern Appalachian streams. *Freshwater Biology* 47:1791-1805
- Tingle CH, Shaw DR, Boyette M, Murphy GP (1998) Metolachlor and Metribuzin Losses in Runoff as Affected by Width of Vegetative Filter Strips. *Weed Science* 46:475-479
- Trimble SW, Mendel AC (1995) The cow as a geomorphic agent -- A critical review. *Geomorphology* 13:233-253
- U.S.Environmental Protection Agency (2000) Atlas of America's Polluted Waters. EPA 840-B00-002, Office of Water (4503F), United State Environmental Protection Agency, Washington, D.C.
- US Environmental Protection Agency (2006) Wadeable Stream Assessment: A Collaborative Survey of the Nation's Streams. EPA 841-B-06-002, United State Environmental Protection Agency, Office of Research and Development, Office of Water, Washington, DC 98 pp
- Wang L, Lyons J, Kanehl P (2002) Effects of watershed best management practices on habitat and fish in Wisconsin streams. *Journal of the American Water Resources Association* 38:663-680
- Waters TF (1995) Sediment in streams: sources, biological effects, and control. American Fisheries Society Monograph 7, Bethesda, Maryland, 251 pp

Westra JV, Zimmerman JKH, Vondracek B (2004) Do Conservation Practices and Programs Benefit the Intended Resource Concern? Agricultural and Resource Economics Review 33:105-120

Wood PJ, Armitage PD (1997) Biological effects of fine sediment in the lotic environment. Environmental Management 21:203-217

Zimmerman JKH, Vondracek B, Westra J (2003) Agricultural Land Use Effects on Sediment Loading and Fish Assemblages in Two Minnesota (USA) Watersheds. Environmental Management 32:93-105

**CHAPTER 2 - RIVERINE THREAT INDICES TO ASSESS WATERSHED CONDITION AND
IDENTIFY PRIMARY MANAGEMENT CAPACITY OF AGRICULTURE NATURAL
RESOURCE MANAGEMENT AGENCIES**

Abstract

Conservation of lotic systems over large geographies can be improved if managers have the tools to assess total watershed conditions for individual stream segments and identify stream segments conservation practices are most likely to be successful. The goal of this research was to develop a suite of threat indices to help agriculture resource management agencies select and prioritize watersheds across the Missouri River basin in which to implement agriculture conservation practices. To accomplish this we first quantified the watershed percentages or densities of seventeen threat metrics that represent major sources of ecological stress to stream communities across the basin into five threat indices: agriculture, urban, point-source pollution, infrastructure, and all non-agriculture threats. Then we identified stream segments where agriculture management agencies have primary management capacity (i.e., the threats in a watershed can best be addressed through agricultural conservation practices applied with NRCS assistance). Agriculture watershed condition differed by region across the basin. Considerable local variation was observed among stream segments in regions of high agriculture threats, indicating the need to account for total watershed condition when allocating conservation resources. Watersheds with high non-agriculture threats were most concentrated near urban areas, but varied among regions and showed high local

variability. Sixty percent of stream segments in the Missouri River basin were classified as under NRCS primary management capacity and most segments were in regions of high agricultural threats. At local scales, NRCS primary management capacity was variable due to the high spatial heterogeneity of non-agriculture threats. This highlights the importance of assessing total watershed condition for multiple threats because abrupt changes in land use influence where agriculture conservation agencies like NRCS have primary management capacity. Our threat indices can be used by agriculture natural resource management agencies, like NRCS, to prioritize conservation actions and investments based on; a) relative severity of all threats, b) relative severity of agricultural threats, and c) relative simplicity and/or degree of primary management capacity. Such threat assessments complement ecological condition assessments by helping resource managers identify the likely environmental stressors and likely sources of stress causing ecological degraded.

Chapter 2 – Summary of Management Opportunities, Use Limitations, and Improvement Options for Riverine Threat Indices to Assess Watershed Condition and Identify Primary Management Capacity of Agriculture Natural Resource Management Agencies

Opportunities for Using Threat Indices and Management Capacity Scores

- Apply threat indices in a flexible manner to assess and prioritize conservation actions at multiple spatial scales to:
 - identify and map prevalence of multiple threats to provide an indirect assessment of ecological condition
 - use as a coarse assessment to determine likely cause(s) of ecological stress
- Use existing management capacity scores, which show prevalence of agricultural threats to other threats, to identify:
 - where agricultural conservation practices (CPs) will likely have measurable benefits without the need for other types of CPs.
 - where non-agricultural CPs would be needed to compliment agricultural CPs.
- Threat metrics and indices establish study designs to:
 - define empirical relations between identified metrics or indices and ecological endpoints.
 - control for one or more human disturbances to isolate relations with other factors of interest.

Limitations and Caveats to Using Threat Indices and Management Capacity Scores

- Threat metric and index scores are presented at stream segment resolution yet reflect total watershed condition.
 - data are not suited for farm-scale planning.
- Threat indices do not include all potential threats.
- Threat metrics and indices represent potential stressors and do not quantify actual stresses (e.g., sediment loading) or severity.
- Management capacity scores are limited to NRCS.

Options for Improvement

- Incorporate additional threat variables into the threat indices.
- Improve the interpretability of the threat indices and develop threat metric weightings by establishing empirical relationships among ecological indicators and threat index scores.
- Identify and implement an objective method to account for threat severity so that threat index scores can more accurately reflect watershed conditions.
 - better representation of prevalence and severity of grazing threats.
 - account for highly erodible agricultural lands to identify those more likely to contribute stress.
- Develop management capacity scores for additional resource management agencies.

Introduction

Restoring natural resources is a process of implementing conservation practices at the correct places to achieve a desired set of conditions (Palmer and others 2005). Decisions on where to focus conservation practices are complicated in stream ecosystems because sources of environmental stress (hereafter, threats) can be distributed anywhere within a watershed and may be far removed from the site of interest, thus highlighting the importance of considering total watershed condition (Wang and others 1997). Managers are increasingly faced with conservation planning over large spatial extents (e.g., states or large river basins) and need tools to help prioritize and select streams on which to focus conservation efforts. Biological assessments of ecological condition are one such tool, but are incomplete over large spatial extents (often <1% of stream miles in a basin are represented; Sowa and others 2007). Thus, management agencies have difficulty in selecting and prioritizing watersheds since ecological condition of unsampled streams is largely unknown. Managers can instead use existing geospatial datasets to conduct watershed scale threat assessments to identify overall watershed condition, identify potential sources of stress in known ecologically degraded streams, and determine if an agency's conservation practices are suitable to address the threats in a watershed (i.e., an agency has primary management capacity).

Threat assessments are typically conducted by developing a multi-metric threat index that uses geospatial data to specify the location and quantify the extent and magnitude of human threats in a watershed by summarizing watershed condition with a single score (Danz and others 2007; Mattson and Angermeier 2007). Threat indices are advantageous over landuse and individual threat metric maps (e.g., locations of point-source discharges) because indices represent overall watershed condition and relativize

watershed condition estimates to the most threatened watershed. Threat indices can be quantified and mapped at a stream segment (length of stream between two confluences) resolution over large spatial extents to include sites lacking a direct assessment of ecological condition. Since most threat indices are made up of multiple threat metrics that represent an array of human disturbances, they can be used to infer the likely source of environmental stress.

When dealing with watersheds where ecological degradation is known, managers should use information from threat assessments to guide conservation practice implementation. Following the conceptual example in Figure 2.1, low Index of Biotic Integrity (IBI; Karr 1981) scores can identify ecologically degraded streams and individual IBI metrics (e.g., proportion of lithophilous spawning fishes) that represent functional community traits may identify the stressor (Leonard and Orth 1986). Stressors can be identified using functional traits of fish communities (e.g., lithophilous spawners) because they can be linked to specific physical drivers or processes that are altered by human threats (Poff 1997; Sutherland and others 2009). Conservation planning is then improved because managers have identified the likely threats causing degradation and are able to make informed decisions regarding the appropriate conservation strategies to address the likely cause of stress (Fig. 2.1). Identifying the likely cause of impairment is particularly important from a logistical standpoint because most resource management agencies have the ability and capacity to address only a select suite of threats.

Selecting conservation sites that are under the primary management capacity of a resource management agency should increase the effectiveness of conservation practices applied by the agency. The primary management capacity of the US Department of

Agriculture's Natural Resource Conservation Service (NRCS) primarily lies in working with producers on mostly privately owned agriculture lands. The agency's conservation practices primarily address environmental stresses caused by agriculture activities, not urban or industrial activities. In the absence of interagency coordination, conservation practice effectiveness would be greatest in watersheds where the most prevalent threats are within the agency's primary management capacity and threats outside its capacity were minimal. Coordination among multiple resource management agencies can be facilitated by knowing the prevalence of threats both within and outside each agency's primary management capacity, thus increasing conservation practice effectiveness. We argue that resource management agencies, like NRCS, would benefit from having stream segment-scale threat indices to assess the relative watershed contribution of various threats (e.g., agriculture vs. urban) for use in strategically allocating resources and more effectively coordinating with other management agencies across a large geography and multiple spatial scales.

To that end, our goal was to develop a suite of threat indices and provide a framework for NRCS and other resource management agencies to select and prioritize watersheds to implement agricultural conservation practices for each of the 450,000+ stream segments in the Missouri River basin. Our objectives were to: 1) quantify the watershed percentages or densities of seventeen threat metrics that represent major sources of ecological stress to stream communities across the basin, 2) conduct a threat assessment to assess total watershed condition for each stream segment using five threat indices developed from the threat metrics: agriculture, urban, point-source pollution, infrastructure, and all non-agriculture threats, and 3) identify stream segments where

NRCS has primary management capacity (i.e., the threats in a watershed can best be addressed through agricultural conservation practices applied with NRCS assistance). An example is provided to demonstrate how decisions regarding conservation can be influenced by using threat and ecological condition assessments. Additionally, although management capacity was not identified for agencies that address non-agricultural threats, the threat indices or scoring criteria used to delineate management capacity herein could be formulated to represent specific agencies as needed.

Methods

Threat indices were developed by mapping multiple threat metrics in a geographic information system and attributing them to a modified geographic framework that represented stream segments within our study area. The prevalence of each threat metric was then quantified for each stream segment's entire watershed and the metric densities were standardized to a common scale (1 to 100). Threat indices were then calculated and scoring criteria were formulated to represent NRCS primary management capacity. Maps and summary statistics were developed for the threat indices and NRCS primary management capacity. Provided is an example of how information obtained from threat and ecological condition assessments can be coupled to inform conservation decision making.

Study area

The Missouri River basin (MORB) is well suited to developing threat indices because of its large geographic area, considerable variation in watershed and stream conditions, and extensive landscape modification (Galat and others 2005; Revenga and others 1998).

The MORB drains about 1,371,017 km² of the United States and 25,100 km² of Canada (Fig. 2.2) (Galat and others 2005). Restoring conditions of MORB altered riverine habitats presents significant challenges to resource managers due to, among other things, the size of the basin and the diversity and spatial distribution of existing threats. Dominant land use and land cover within the basin includes 25% cropland, 48% grassland/pasture, 10% forest, 11% shrub, 3% urban, 2% wetland, and 1% open water (Homer and others 2004). Agriculture threats (row-crop and grazing) are most prevalent across MORB but considerable spatial heterogeneity exists among agriculture and non-agriculture threats (e.g., point-source pollution, urbanization, and mining activities) making the prioritization of agriculture lands to be enrolled in conservation practices a significant challenge.

Geographic Framework

The base stream layer was acquired from work done for the Missouri River Basin Aquatic Gap Project (Annis and others 2009a). These stream networks represent a modified version of the 1:100,000 National Hydrography Dataset (NHD; U.S. Geological Survey and U.S. Environmental Protection Agency 2008). The primary modification of the NHD was the repair of gross underrepresentation of stream density in portions of the basin corresponding to select 1:100,000 scale topographic maps. The resulting stream networks were also processed to remove loops and braids within the network that caused problems with geoprocessing tasks of quantifying threat prevalence throughout the MORB. We used 30-meter digital elevation models from the NHDPlus (U.S. Geological Survey and U.S. Environmental Protection Agency 2008) and ArcHydro Tools (ArcGIS

9.3, ESRI, Redlands, CA) to create corresponding local catchment polygons (i.e., the land immediately draining a stream segment) for each of the 464,118 individual stream segments in the resulting MORB stream network. The resulting stream segments and catchment polygons were used as the spatial framework for quantifying and mapping the individual threat metrics and multimetric threat indices for this project.

Rationale and General Approach to Threat Index Development

The structure and components of a threat index influence how sources of stress are represented on the landscape and the degree to which inferences can be made regarding likely sources of degradation and potential stress. The number of threats evaluated in an index affects its comprehensiveness and ability to identify all potential sources of stress. Threats are quantified to assess their prevalence and are recorded as unit density, usually as proportion of watershed (e.g., proportion of row-crop) or number of units per watershed area (e.g., number of discharges per square kilometer), for an assessment region. The most influential component affecting the interpretation of an index is how threat prevalence (i.e., extent) and severity (i.e., magnitude) are represented, as these metrics largely determine the final representation of potential stress. Threat prevalence essentially identifies the most abundant threat(s) across the landscape. The most precise prevalence estimates are those represented by the actual threat density or proportion of watershed value (e.g., 25% of watershed area) and least precise are estimates that categorize prevalence (e.g., 0-25% =1 etc.). The spatial scale at which threat prevalence is quantified affects the ability of threat indices to inform decisions regarding placement of conservation practices. As spatial grain increases (e.g., from

local contributing areas to 8-digit Hydrologic Unit Codes), the representation of threat prevalence becomes more generalized and the ability to identify fine-scale spatial patterns is reduced or eliminated. Threat severity provides a measure of threat influence on an ecological indicator. For example, Mattson and Angermeier (2007) used professional judgment to weight threat severity by the degree to which each threat affects the five components of biological integrity (Karr and others 1986). Therefore, the ecological indicator used to assign threat severity influences our interpretation about the magnitude of sources of stress.

Since ecological response to threat prevalence and magnitude is expected to differ among ecoregions, we relativized our threat indices to ecoregions to reflect potential differences (Frimpong and Angermeier 2010). The MORB was divided into five ecoregions using Bailey's (1983) division-level classification that accounts for differences in climate, geology, and soils.

Seventeen threats metrics were used to develop five multimetric indices representing major categories of sources of ecological stress and to identify NRCS management capacity: agriculture, urbanization, point-source pollution, infrastructural threats (those occurring directly in stream channels), and all non-agriculture threats (Table 2.1). The threat metrics used in the indices were chosen because data were publicly available, reasonably consistent in coverage across the MORB, and represent the major threats to aquatic systems. The agriculture threat index represents the major agriculture threat metrics to aquatic systems (Table 2.1). Row-crop agriculture and grazing affect sedimentation regimes (Waters 1995) while channelization directly modifies channel structure, physical habitat (Frothingham and others 2001), and

hydrology (Rhoads and others 2003). The threat metrics in the urbanization index (Table 2.1) represent hydrologic alterations from impervious surfaces (Roy and others 2005), pollution from densely populated areas (Hatt and others 2004; Young and Thackston 1999), and potential increases in sedimentation due to construction from increasing population density (Wolman and Schick 1967). The point-source pollution index represents pollution sources that have potential direct effects on aquatic biota (Table 2.1). The infrastructure index represents threat metrics occurring in a stream channel that can be readily mapped in a GIS (Table 2.1). Road and rail stream crossings affect physical stream habitats (Bouska and others 2010) and dams cause alterations in physical habitat (Kondolf 1997; Ligon and others 1995) and hydrologic regime (Poff and others 2007). The non-agriculture index collectively represents all threats from the urbanization, point-source pollution, and infrastructure indices (Table 2.1).

Each threat metric and index represents the potential “risk” of environmental stress resulting from the corresponding metric or index. Risk was assumed to be equal across all threats (i.e., all threats were assumed to have the same potential risk) and increase as threat prevalence increased. This is because we did not have adequate empirical information relating threat prevalence to ecological indicators, which would have allowed for ecologically-meaningful weighting of threat metrics. When thresholds of ecological responses to threats are unknown, threat index scores are unlikely to be improved (Paukert and others 2011). We standardized each threat *metric* so that comparisons could be made among threats recorded in different measurement units (e.g., to compare proportion of watershed vs. point densities). Additionally, we standardized

each threat *index* to a common scale so that direct comparisons could be made among indices.

Modified Threat Metric Data

Four threat metrics required creation or modification from their original form and are described below. Grazing and stream channelization threats were not appropriately represented in existing data sources and were modified. Impervious surfaces were overestimated in the NLCD and population change information needed to be quantified.

Estimated grazing

Livestock grazing can significantly influence watershed hydrology, sediment, and nutrient regimes of streams (Belsky and others 1999; Meehan and Platts 1978). Because of this potential influence on stream condition and that livestock grazing is not accurately represented in the 2001 NLCD, we took steps to create a dataset to more accurately represent grazed land across the MORB. The closest approximation to grazed lands in the NLCD is the pasture or hay field landcover class, but there is no landcover class that accounts for grazing activity on native rangelands (i.e., lands suitable to grazing that have not been planted to monoculture). The primary issue is that the pasture/hay landcover class is not used in the western part of the basin where native rangelands are commonly grazed; instead, landcover in the west is generally considered grassland or shrubland. We used data from the U.S. Department of Agriculture's Agriculture Census (2007) that quantified the amount of grazed rangeland and pastureland within 6-digit Hydrologic Unit Codes (HUC) of the MORB. The amount of grassland, shrubland, and

pasture/hayfield landcover classes were then summed by 6-digit HUC and assumed to represent the total amount of rangeland within each HUC. The area of reported grazed land was then divided by total available rangeland in each HUC to estimate the percentage of rangeland that was grazed within each HUC. For each local catchment polygon we then calculated the percentage of rangeland from the 2001 NLCD and multiplied that value by the estimated percentage of rangeland that was grazed for the corresponding 6-digit HUC that contained that particular polygon.

Channelized streams

Channelized streams are a common feature of most agriculture regions and can cause significant ecological degradation (Waters 1995). Unfortunately, we lacked a single dataset of channelized streams covering the entire MORB. However, given the significance of this threat to stream conditions we created a basinwide data layer of channelized streams in MORB by combining data from multiple geospatial sources. The resulting dataset consisted of all ditches or channelized pieces of stream that could be identified using three input datasets: the 1:24,000 NHD (U.S. Geological Survey and U.S. Environmental Protection Agency 2008), a modified version of the 1:100,000 NHD (U.S. Geological Survey and U.S. Environmental Protection Agency 2008), and the National Wetlands Inventory (NWI; 2006). We used existing stream classification from the aforementioned data to determine stream segments that were channelized or ditched. After merging the three files, there were apparent data gaps in specific regions so we consulted experts and used professional judgment to identify and map the remaining channelized stream segments by visually examining the digital network overlaid on

multiple sources of aerial photography. Professional judgment was used to identify channels with a straight planform that appeared channelized.

Impervious surfaces

Odd spatial patterns that followed administrative boundaries were observed when watershed percentages were calculated for impervious surfaces using the 2001 NLCD (Homer and others 2004). Upon closer examination, inconsistencies were found in how impervious surfaces were classified as “developed”. For instance, most of the unpaved, gravel, roads were classified as developed in Iowa, but not other states. We observed that the 2001 NLCD consistently represented paved rural roads that were usually ~30 m wide, with two or three 30-meter pixels. Therefore, the area of impervious surfaces was grossly overestimated by the contribution of rural roads. This problem was addressed by using a shrink and expand process on the NLCD impervious surface class that removed the “extra” pixels causing the overestimation and reassigned them to the surrounding landcover using ArcGIS 9.3.

Population density and population change

Actively developing areas can often be some of the most degraded ecosystems, particularly with regard to streams. Rapidly developed areas have significantly altered hydrology and large areas of exposed soils that can contribute large volumes of sediment to streams (Waters 1995). To identify and quantify the prevalence of areas with rapid development we used the 1990 and 2000 census block data (U.S. Census Bureau 1990, 2000) to assign the population from each census block to our local catchment polygons

based on the percentage of block area located within each catchment. This process yielded a population from both 1990 and 2000 attached to each catchment polygon, which was used to compute a population change by subtracting the population density in 1990 from 2000. Due to time constraints, we were unable to incorporate the most recent (2010) U.S. Census data into our calculations of population density and population change, which may affect localized representations of urbanization impacts.

Quantifying Threat Prevalence

Individual threat metric prevalence was quantified within each of the local catchment polygons. Then we used customized Arc Macro Language (ESRI, Redlands, CA) programs to sum all of these values for each individual stream segment's entire watershed (i.e., the local catchment and all upstream catchments that a segment drains). We then divided these summed values by the overall watershed area to quantify the prevalence, per unit area or as proportion of watershed, of each threat metric within the watershed of each segment.

Threat Metric and Index Calculations

Threat metrics were removed from our dataset, to reduce redundancy in our representation of threats (Stoddard and others 2008), if they were significantly correlated with a threat metric that could appropriately represent the removed metric (e.g., road density can be represented as an impervious surface, but not by cropland). Metrics were removed if their Pearson correlation coefficient was >0.55 and $p < 0.05$ (corrected for multiple comparisons using Bonferroni adjustments).

Threat metric scores (T_s) were calculated as

$$T_{s_{i,j}} = \left[\frac{Tr_{i,j}}{\max(Tr_{i,j})} \right] \times 100$$

where $Tr_{i,j}$ is the ranked value of threat prevalence (as total contributing area) for every stream segment (i.e., the stream segment with the lowest threat prevalence received a rank of one and the stream segment with the highest density received the highest rank). Ties in threat prevalence were given the same rank. To standardize the threat metric scores (T_s), each segment's ranked threat prevalence score (Tr) was divided by maximum ranked value for its corresponding ecoregion and multiplied by 100 (range: 0 – 100). Values of 100 represent the highest threat prevalence.

Threat index scores (TI) were calculated and standardized by summing the corresponding threat metric scores (T_s) for each index (Table 2.1).

$$TI_{i,j} = \left[\frac{T_{s_{i,j}} + \dots + T_{s_n}}{\max(T_{s_{i,j}} + \dots + T_{s_n})} \right] \times 100$$

Index scores of 100 represent stream segments with highest potential stress. Final threat index scores were then incorporated into a seamless stream layer database and mapped in ArcGIS (ESRI, Redlands, CA).

Agriculture Conservation Program Primary management capacity Matrix

A matrix was developed to determine the degree of NRCS management capacity for stream segments based on watershed condition. Since conservation programs target a limited suite of threats, implementing agricultural conservation practices in watersheds where NRCS has primary management capacity should increase conservation practice effectiveness. We did not distinguish between private and public lands, and it should be

noted that public lands are generally not within NRCS management capacity; management capacity of public lands is under the agency responsible for managing those lands. In this paper, agriculture threats are considered *target threats* and all other threats are considered *non-target threats*. The matrix was used to determine the relative degree of NRCS management capacity by assessing the potential stress from target threats, relative to potential non-target stress for each segment. For each stream segment, its agriculture and non-agriculture threat index scores were given a quartile score (i.e., index score $0 - 25 = 1$, $25 - 50 = 2$, etc.; Table 2.2). (Different scoring criteria would be acceptable to formulate this matrix if quartile scores were deemed too coarse a resolution.) The upper half of the matrix was populated by dividing the agriculture (i) and non-agriculture (j) quartile scores for each X_{ij} . Matrix scores were then transposed to the corresponding X_{ij} on the lower half of the matrix and given negative values. Positive scores indicate stream segments where NRCS is most likely to have primary management capacity and the more positive the score, the more likely NRCS is to have greater management capacity (Table 2.2). Matrix scores ≥ 2 were considered to represent primary NRCS management capacity. (The threshold of ≥ 2 is presented here as an illustration and could be altered to suit an agency's needs.)

Example of coupling threat and ecological condition assessments

We obtained fish IBI scores from four sites in MORB (Fig. 2.3) to identify ecologically degraded streams and to illustrate how the conceptual process outlined in Figure 2.1 could be utilized by resource managers. We haphazardly selected four streams that spanned the overall range of IBI scores. The IBI scores were computed for the US

Environmental Protection Agency's (EPA) Regional Environmental Monitoring and Assessment Program in EPA Region 7 (M. Combes, unpublished data). The IBI was applicable to streams across the entire EPA Region 7 and contained the metrics (all metrics were evaluated as "number of"): native species, native families, native individuals, sensitive individuals, tolerant individuals, benthic species, native sunfish species, minnow species, long-lived species, introduced species, trophic strategies, native carnivore species, native omnivore and herbivore species, and reproductive strategies. The individual metrics for the IBI were evaluated to identify potential stressors causing ecological degradation. Threat index scores for each site were then compared relative to the overall IBI score and the individual IBI metrics to evaluate the likely sources of ecological stress as they pertain to conservation decision making.

Results

Percent impervious surface was significantly and highly correlated with developed open ($r = 0.59$), low ($r = 0.96$), medium ($r = 0.91$), and high ($r = 0.66$) urban land-use variables from the NLCD as well as road density ($r = 0.85$); therefore, these metrics were not included in the threat indices. As a result, percent impervious surface in a contributing area was used to represent correlated urban land use and road density threats.

Patterns of potential stress were evident at regional scales, but we identified localized patterns of potential stress that showed considerable spatial heterogeneity. Agriculture threats are most prominent across the MORB and on average stream segments have higher potential agriculture stress (Table 2.3). Mean threat index scores significantly varied among the five ecoregions of the Missouri River basin, indicating

potential stress varies among the ecoregions (Table 2.3). Visual examination of mapped output for the agriculture threat index (Fig. 2.4) illustrates that regional patterns in threat stress exist, e.g., high agriculture threats in the east-central portion of the basin.

Although strong regional patterns of potential agriculture threat stress were evident, there was considerable spatial heterogeneity in potential agriculture stress at localized scales (see inset Fig. 2.4). Similar patterns exist when examining non-agriculture threat stress across the basin (Fig. 2.5). Non-agriculture threats primarily occur in or near urban areas. Non-agriculture threats were locally heterogenous, but these patterns were not evident on landcover maps because they do not account for watershed condition (see inset Fig. 2.5).

Matrix scores ≥ 2 were considered representative of segments where NRCS had primary management capacity. Based on this criterion, NRCS had primary management capacity for 60% of stream segments in MORB. NRCS had primary management capacity in 55% of Prairie Division, 76% of Temperate Steppe Division, 24% of Hot Continental Division, 14% of Temperate Desert Division, and 29% of Temperate Steppe Regime Mountain stream segments. Regional patterns in NRCS primary management capacity were evident across MORB and generally followed the patterns of potential agriculture stress (Fig. 2.6).

The four sites evaluated for fish biotic integrity ranged from poor (site 1 = 14) to excellent (site 4 = 96) ecological condition and two sites were intermediate (Table 2.4). Sites 1, 2, and 3 had low benthic metric scores (Table 2.5) (fishes that feed and reproduce in the benthos and are sensitive to sedimentation; Barbour and other 1999). Sites 1 and 3 had the highest agricultural threat index scores (Table 2.4). Site 2 had a relatively high

urban threat index score and moderate point-source pollution and infrastructure threat index scores (Table 2.4). All threat indices in site 4 had low scores (Table 2.4).

Discussion

Threat indices were used to identify regional and local patterns of multiple agriculture and non-agriculture threats for every stream segment in MORB. The threat patterns were similar to those of landcover maps; however, unlike landcover maps our threat indices represent watershed condition for multiple threats. Within highly impacted agriculture regions, there was considerable variation in watershed condition among stream segments. This highlights the importance of cautiously using landcover map information to make resource conservation decisions.

Coupling ecological condition and threat assessments allows resource managers to identify ecologically degraded sites and the threats most likely causing degradation, helps provide information needed to select appropriate conservation practices. The spatial resolution (stream segments) of our threat indices allows them to be coupled with field-based ecological data and potential sources of stress can be evaluated for essentially any biological stream sample. However, because our maps and resulting threat index scores represent total watershed condition users should recognize that the indices cannot inform farm-scale planning efforts. Using Figure 2.1 and our IBI example as an illustration, sites 1, 2, and 3 had overall IBI scores that indicated ecological degradation and the benthic IBI metric was low in each stream (relative to the least disturbed site 4), which suggested that sedimentation was an ecological stress (Barbour and others 1999). This example serves as illustration of how managers can use threat indices and biological information to quickly and efficiently reduce uncertainty regarding the threats most likely

causing ecological degradation. The high agricultural threat index scores from sites 1 and 3 suggested that potential sedimentation stresses most likely originated from agriculture threats and possibly from urbanization threats in site 1, which indicates that agricultural conservation practices administered by agencies like NRCS would be the most appropriate for stream restoration. Threat index scores for site 2 suggested that sedimentation stress originated from urban threats and that point-source pollution and infrastructure threats may contribute additional stresses (Table 2.4). In this instance, conservation practices or policies administered by state or federal water quality authorities (e.g.,) USEPA and local municipalities would be most appropriate. Finally, site 4 had the highest ecological condition and correspondingly low threat index scores, suggesting a need for proactive (i.e., preventing further degradation) rather than restorative conservation practices.

For threat indices to be widely used by multiple resource agencies, indices need to be applicable to multiple ecological indicators. Most published threat indices are limited in their use outside of the taxa or ecological indicators they were developed for because the indices account for threat severity by weighting the relative influence of threat metrics to an ecological indicator (e.g., Esselman and others 2010; Mattson and Angermeier 2007). For example, in Wisconsin streams, urbanization threats are more likely to degrade fish assemblages than agriculture threats and would thus be weighted as more severe (Wang and others 1997). Unfortunately, different taxa have been shown to respond differentially to the same source of stress (Berkman and others 1986), therefore severity weights for threat metrics are likely applicable only to the ecological indicator being evaluated. Incorporating measures of threat severity in threat indices is unlikely to

improve threat index scores because we hardly ever know the thresholds of threat prevalence that cause change in ecological condition (Paukert and others 2011). Additionally, assigning weights to individual threat metrics must often be done subjectively and it is likely that true thresholds of severity will be misrepresented. In a comparative analysis, Paukert and others (2011) found that weighting threat indices produced nearly identical scores relative to scores from an unweighted index. This suggests that weighting threat indices is unlikely to increase biological realism, especially when weighting schemes involve subjectivity. Instead of accounting for severity, we argue that resource managers would be better off by establishing empirical relationships between threat indices and an ecological indicator to account for threat severity. Our contention is that because relationships between a threat index and ecological indicator are likely to vary by region and taxon (Frimpong and Angermeier 2010) that threat index scores should not be altered depending on the ecological indicator being evaluated. Instead, managers can alter their interpretation of threat index scores by establishing empirical relationships between threat indices and ecological indicators (e.g., a threat index score of 50 in one region and a score of 65 in another region may represent the equivalent degree of degradation). Doing so allows threat indices to be easily computed, avoids making assumptions about threat impacts to ecological indicators across different regions, and increases an index's applicability to resource managers.

In most watersheds, multiple threats affect ecological condition (Diana and others 2006; Zorn and Wiley 2006), and it is likely that addressing conservation concerns for an area will involve multiple agencies who have distinct management authorities. We estimated that agriculture conservation programs such as those administered by NRCS

would have primary management capacity for a majority (60%) of the stream segments in MORB. However, some lands within the MORB are under public ownership and management (e.g., national forests and grazing lands therein are managed by the US Forest Service), and may contain agricultural threats. Public lands are areas where NRCS would not have primary management capacity, as threats on those lands would be addressed by the managing agency. Given the existing regional patterns, there is considerable heterogeneity in NRCS primary management capacity across the landscape as non-agriculture threats are often prevalent enough outside of urban areas. Three of the five MORB ecoregions had NRCS primary management capacity in only 14 to 29% of stream segments, indicating that relative to agriculture non-agriculture threats are the predominate threat. Effective conservation in those ecoregions may require collaboration among multiple resource agencies. Although management capacity was not identified for non-agriculture conservation programs, the threat indices or scoring matrix could be reformulated to meet desired needs. For example, our point-source pollution index could be viewed as best addressed by the U.S. Environmental Protection Agency because they permit and regulate point-sources of pollution (US Environmental Protection Agency 2001). Developing comprehensive management programs (among multiple management agencies) requires agencies to examine the relative contribution of stress from target threats (threats within their management capacity) to those of another agency so collaboration can be successful.

Conducting stream conservation efforts at large geographic areas involves identifying and prioritizing conservation areas (Groves and others 2002). Threat indices can be used as tools to explicitly identify potential sources of stress on the landscape,

identify agencies that have management capacity over assessment units, and establish relationships with ecological indicators to determine potentially degraded systems. The threat indices and primary management capacity scoring systems we developed could be used in a winnowing process to identify and select subsets of stream segments for stream conservation. The regional patterns we observed in potential stresses could be used as a “first-cut” in a winnowing process to select broad geographic areas to focus conservation program implementation. In the MORB example, the Prairie and Temperate Steppe Divisions tend to be the most agriculturally threatened and could be the focus of NRCS conservation programs. Next, threat indices can be used to identify individual stream segments within regions where NRCS has primary management capacity, and presumably a greater chance of achieving conservation success. Where ecological condition is known, resource managers should use threat indices to establish relationships among ecological indicators because ecological indicators respond differently to threats (Danz and others 2007; Frimpong and Angermeier 2010). Once relationships among indicators are successfully established, resource managers can then interpret their threat index scores in an ecologically meaningful manner and select the appropriate conservation programs to implement.

References

- Annis GM, Sowa SP, Diamond DD, Combes MD, Doisy KE, Garringer AJ, Hanberry P (2009) Developing Synoptic Human Threat Indices for Assessing the Ecological Integrity of Freshwater Ecosystems in EPA Region 7. Final report, submitted to Environmental Protection Agency, 192 pp
- Bailey RG (1983) Delineation of ecosystem regions. *Environmental Management* 7:365-373
- Barbour MT, Gerritsen J, Snyder BD, Stribling JB (1999) Rapid Bioassessment Protocols for Use in Streams and Wadeable Rivers: Periphyton, Benthic Macroinvertebrates and Fish, Second Edition. EPA 841-B-99-002, U.S. Environmental Protection Agency, Office of Water, Washington, D.C.
- Belsky AJ, Matzke A, Uselman S (1999) Survey of livestock influences on stream and riparian ecosystems in the western United States. *Journal of Soil and Water Conservation* 54:419-431
- Berkman HE, Rabeni CF, Boyle TP (1986) Biomonitoring of stream quality in agricultural areas: Fish versus invertebrates. *Environmental Management* 10:413-419
- Bouska WW, Keane T, Paukert CP (2010) The Effects of Road Crossings on Prairie Stream Habitat and Function. *Journal of Freshwater Ecology* 25:499-506
- Danz N, Niemi G, Regal R, Hollenhorst T, Johnson L, Hanowski J, Axler R, Ciborowski J, Hrabik T, Brady V, Kelly J, Morrice J, Brazner J, Howe R, Johnston C, Host G (2007) Integrated Measures of Anthropogenic Stress in the U.S. Great Lakes Basin. *Environmental Management* 39:631-647

- Diana M, Allan JD, and Infante D. The influence of physical habitat and land use on stream fish assemblages in southeastern Michigan. Hughes, Robert M., Wang, Lizhu, and Seelbach, Paul W. Landscape Influences on Stream Habitats and Biological Assemblages. 359-374. 2006. Bethesda, Maryland, American Fisheries Society, Symposium 48.
- Esselman, P. C., D. M. Infante, L. Wang, D. Wu, A. Cooper, and W. W. Taylor. 2010. An initial assessment of relative landscape disturbance levels for river fish habitats of the conterminous United States. National Fish Habitat Action Plan.
- Frimpong EA, Angermeier PL (2010) Comparative Utility of Selected Frameworks for Regionalizing Fish-Based Bioassessments across the United States. Transactions of the American Fisheries Society 139:1872-1895
- Frothingham KM, Rhoads BL, Herricks EE (2001) Stream geomorphology and fish community structure in channelized and meandering reaches of an agricultural stream. In: Dorava JM, Montgomery DR, Palcsak BB, Fitzpatrick FA (eds), Geomorphic Processes and Riverine Habitat. American Geophysical Union, Washington D.C., pp 105-117
- Galat DL, Berry CR, Peters EJ, White RG (2005) Missouri River Basin. In: Benke AC, Cushing CE (eds), Rivers of North America. Elsevier, Oxford, pp 427-480
- Groves CR, Jensen DB, Valutis LL, Redford KH, Shaffer ML, Scott JM, Baumgartner JV, Higgins JV, Beck MW, Anderson MG (2002) Planning for Biodiversity Conservation: Putting Conservation Science into Practice. BioScience 52:499-512

- Hatt BE, Fletcher TD, Walsh CJ, Taylor SL (2004) The Influence of Urban Density and Drainage Infrastructure on the Concentrations and Loads of Pollutants in Small Streams. *Environmental Management* 34:112-124
- Homer C, Huang C, Yang L, Wylie B, Coan M (2004) Development of a 2001 national landcover database for the United States. *Photogrammetric Engineering and Remote Sensing* 70:829-840
- Karr JR, Fausch KD, Angermeier PL, Yant PR, Schlosser IJ (1986) Assessing Biological Integrity in Running Waters: A Method and its Rationale. Special Publication 5, Illinois Natural History Survey, Urbana, Illinois
- Karr JR (1981) Assessment of biotic integrity using fish communities. *Fisheries* 6:21-27
- Kondolf GM (1997) Hungry water: Effects of dams and gravel mining on river channels. *Environmental Management* 21:533-551
- Leonard PM, Orth DJ (1986) Application and Testing of an Index of Biotic Integrity in Small, Coolwater Streams. *Transactions of the American Fisheries Society* 115:401-414
- Ligon FK, Dietrich WE, Trush WJ (1995) Downstream Ecological Effects of Dams. *BioScience* 45:183-192
- Mattson KM, Angermeier PL (2007) Integrating Human Impacts and Ecological Integrity into a Risk-Based Protocol for Conservation Planning. *Environmental Management* 125-138
- Meehan WR, Platts WS (1978) Livestock grazing and the aquatic environment. *Journal of Soil and Water Conservation* 33:274-278

- Palmer MA, Bernhardt ES, Allan JD, Lake PS, Alexander G, Brooks S, Carr J, Clayton S, Dahm CN, Shah JF, Galat DL, Loss SG, Goodwin P, Hart DD, Hassett B, Jenkinson R, Kondolf GM, Lave R, Meyer JL, O'Donnell TK, Pagano L, Sudduth E (2005) Standards for ecologically successful river restoration. *Journal of Applied Ecology* 42:208-217
- Paukert CP, Pitts KL, Whittier JB, Olden JD (2011) Development and assessment of a landscape-scale ecological threat index for the Lower Colorado River Basin. *Ecological Indicators* 11:304-310
- Poff NL (1997) Landscape filters and species traits: Towards mechanistic understanding and prediction in stream ecology. *Journal of the North American Benthological Society* 16:391
- Poff NL, Olden JD, Merritt DM, Pepin DM (2007) Homogenization of regional river dynamics by dams and global biodiversity implications. *Proceedings of the National Academy of Sciences* 104:5732-5737
- Revenge C, Murray S, Abramovitz J, Hammond A (1998) *Watersheds of the World: Ecological Value and Vulnerability*. Worldwatch Institute, Washington, D.C.,
- Rhoads BL, Schwartz JS, Porter S (2003) Stream geomorphology, bank vegetation, and three-dimensional habitat hydraulics for fish in midwestern agricultural streams. *Water Resources Research* 39:2.1-2.3
- Roy AH, Freeman MC, Freeman BJ, Wenger SJ, Ensign WE, Meyer JL (2005) Investigating hydrologic alteration as a mechanism of fish assemblage shifts in urbanizing streams. *Journal of the North American Benthological Society* 24:656-678

- Sowa SP, Annis G, Morey ME, Diamond DD (2007) A GAP analysis and comprehensive conservation strategy for riverine ecosystems of Missouri. *Ecological Monographs* 77:301-334
- Stoddard JL, Herlihy AT, Peck DV, Hughes RM, Whittier TR, Tarquinio E (2008) A process for creating multimetric indices for large-scale aquatic surveys. *Journal of the North American Benthological Society* 27:878-891
- Sutherland AB, Meyer JL, Gardiner EP (2002) Effects of land cover on sediment regime and fish assemblage structure in four southern Appalachian streams. *Freshwater Biology* 47:1791-1805
- US Environmental Protection Agency OoW (2001) Protecting the Nation's Waters Through Effective NPDES Permits: A Strategic Plan Fy 2001 and Beyond. EPA-833-R-01-001, United States Environmental Protection Agency, Office of Water, Washington, DC. 15 pp
- Wang L, Lyons J, Kanehl P, Gatti R (1997) Influences of Watershed Land Use on Habitat Quality and Biotic Integrity in Wisconsin Streams. *Fisheries* 22:6-12
- Waters TF (1995) Sediment in streams: sources, biological effects, and control. *American Fisheries Society Monograph* 7, Bethesda, Maryland, 251 pp
- Wolman MG, Schick AP (1967) Effects of construction on fluvial sediment, urban and suburban areas of Maryland. *Water Resour.Res.* 3:451-464
- Young KD, Thackston EL (1999) Housing Density and Bacterial Loading in Urban Streams. *Journal of Environmental Engineering* 125:1177-1180
- Zorn TG, Wiley MJ (2006) Influence of landscape characteristics on local habitat and fish biomass in streams of Michigan's lower peninsula. In: Hughes RM, Wang L,

Seelbach PW (eds), Landscape influences on stream habitats and biological assemblages. American Fisheries Society, Symposium 48, Bethesda, Maryland, pp 375-393

Table 2.1. Threat metrics and their data sources used to calculate five threat indices within the Missouri River basin. Abbreviations for the threat indices are AR = Agricultural, UR = Urbanization, PSP = Point-source Pollution, IN = Infrastructure, and NAG = Non-agricultural.

Threat Dataset (measurement unit)	Modified	Threat Index					Data Sources ^a	Source Date
		AG	UR	PSP	IN	NAG		
Row-Crop Agriculture (% of watershed)	No	X					U.S.G.S. - 2001 NLCD	2006
							Canada National Land and Water Information Service	2007
Estimated Grazing (% of watershed)	Yes	X					U.S. Department of Agriculture – 2006 Agriculture census	2006
							U.S.G.S. - 2001 NLCD	2006
Channelized Streams (km/km ²)	Yes	X					U.S.G.S. - 24k NHD	Varies
							U.S.G.S. and EPA - 100k NHD	2006
							U.S.G.S. Wetland Mapper Team - National Wetlands Inventory	2006
Impervious Surface (% of watershed)	Yes		X			X	U.S.G.S. - 2001 NLCD	2006
							Canada National Land and Water Information Service	2007

Population Density 2000 (#/km ²)	Yes	X	X	U.S. Census Bureau – 2000 Block Data	2000
				Statistics Canada	2007
Population Change 1990 – 2000 (#/km ²)	Yes	X	X	U.S. Census Bureau – 1990 Block Data	1990
				U.S. Census Bureau – 2000 Block Data	2000
				Statistics Canada	2007
Coal Mines (#/km ²)	Yes	X	X	EPA - Better Assessment Science Integrating Point & Non-point Sources	2001
				Canada National Pollutant Release Inventory Data	2008
				University of Nebraska - Lincoln	1996
				Iowa Department of Natural Resources	2003
Lead Mines (#/km ²)	No	X	X	EPA - Better Assessment Science Integrating Point & Non-point Sources	2001
Other Mines (#/km ²)	Yes	X	X	U.S.G.S.	2005
				Canada National Pollutant Release Inventory Data	2008

	CERCLIS Sites ^b (#/km ²)	Yes	X	X	EPA – Envirofacts	2007
	Toxic Release Inventory Sites (#/km ²)	Yes	X	X	EPA – Envirofacts	2007
	RCRA Sites ^c (#/km ²)	Yes	X	X	EPA – Envirofacts	2007
50	NPDES Sites ^d (#/km ²)	Yes	X		EPA – Envirofacts	2006, 2008
	Landfills (#/km ²)	Yes	X	X	EPA - Better Assessment Science Integrating Point & Non-point Sources	2001
					Missouri Department of Natural Resources	2006
					Canada National Pollutant Release Inventory Data	2008
	Dams (#/km ²)	No	X	X	National Inventory of Dams. U.S. Army Corps of Engineers	1996
					Canadian National Topographic Database	Unknown

Road Stream Crossing (#/km ²)	Yes	X	X	Census Bureau -TIGER	1999
				Statistics Canada	2008
				Missouri Resource Assessment Partnership - Streams	2009
Rail Stream Crossing (#/km ²)	Yes	X	X	Census Bureau -TIGER Database	1999
				Statistics Canada	2008
				Missouri Resource Assessment Partnership - Streams	2009

^aU.S.G.S = United States Geological Survey; NLCD = National Land Cover Database; EPA = United States Environmental Protection Agency; NHD = National Hydrography Database; TIGER = Topologically Integrated Geographic Encoding and Referencing database.

^bCERCLIS = Comprehensive Environmental Response, Compensation, and Liability Information System

^cRCRA = Resource Conservation & Recovery Act

^dNPDES = National Pollutant Discharge Elimination System

Table 2.2. Scoring matrix used to identify stream segments where NRCS had primary management capacity (see text for explanation) in the Missouri River basin. Stream segments that had scores ≥ 2 were considered to be under the primary management capacity of NRCS. Values in parentheses represent threat index scores.

Non-agriculture Quartile Scores	Agriculture Threat Quartile Scores			
	1 (0-25)	2 (25-50)	3 (50-75)	4 (75-100)
1 (0-25)	1	2	3	4
2 (25-50)	-2	1	1.5	2
3 (50-75)	-3	-1.5	1	1.3
4 (75-100)	-4	-2	-1.3	1

Table 2.3. Mean and standard error of threat index values for the Missouri River basin calculated within Bailey's (1983) divisions. One-way analysis of variance was conducted to determine if means significantly differed by division. Superscripts of different letters indicate a significant difference in mean threat index scores among the ecoregions (row comparisons only). Refer to Fig. 2.2 for map of divisions.

Threat Index	Division					
	Missouri River Basin	Hot Continental	Prairie	Temperate Desert	Temperate Steppe	Temperate Steppe Regime Mountains
Agriculture	43.24 (0.03)	32.30 ^a (0.15)	48.81 ^b (0.05)	33.29 ^c (0.14)	46.76 ^d (0.03)	26.75 ^e (0.08)
Urbanization	28.57 (0.02)	35.47 ^f (0.15)	34.07 ^g (0.06)	27.04 ^h (0.11)	26.57 ^h (0.03)	25.65 ⁱ (0.07)
Infrastructure	16.55 (0.02)	18.90 ^k (0.11)	22.27 ^l (0.05)	18.56 ^k (0.12)	14.73 ^m (0.03)	13.10 ⁿ (0.06)
Point-source Pollution	17.26 (0.01)	23.52 ^p (0.08)	17.52 ^q (0.02)	26.58 ^r (0.05)	16.00 ^s (0.01)	17.23 ^t (0.02)
Non-agriculture	22.94 (0.01)	28.07 ^u (0.09)	25.83 ^v (0.03)	31.16 ^w (0.08)	20.94 ^x (0.01)	22.20 ^y (0.04)

Table 2.4. Fish Index of Biotic Integrity (IBI) and threat index scores from four stream sites in Missouri River basin. Higher IBI scores indicate higher biotic integrity. Higher threat index scores indicate higher threat prevalence.

Site	IBI Score	Index				
		Agriculture	Point-source Pollution	Urbanization	Infrastructure	Non-agriculture
1	14	78.76	24.66	42.97	27.47	33.96
2	37	14.04	46.72	93.19	55.14	67.23
3	63	41.15	15.22	19.09	7.75	16.46
4	96	6.33	18.44	13.10	25.93	20.90

Table 2.5. Fish Index of Biotic Integrity (IBI) and metric scores for four streams in the Missouri River basin. Higher IBI and metric scores indicate higher biotic integrity. NAT = native species, NAF = native families, IND = native individuals, SENS = sensitive species, TOL = tolerant species, BNTH = benthic species, SUN = native sunfish species, MIN = minnow species, LOL = long-lived species, INT = introduced species, TRO = trophic strategies, NAC = native carnivore species, NOH = native omnivore and herbivore species, and REP = reproductive strategies.

Site	IBI Score	IBI Metric Scores (number of)													
		NAT	NAF	IND	SENS	TOL	BNTH	SUN	MIN	LOL	INT	TRO	NAC	NOH	REP
1	14	0.94	2.41	1.52	0	0	0	0	1.9	0	10	0	0	0	2.91
2	37	2.05	4.65	3.75	0	0.32	0	4.55	1.19	3.47	10	2.07	10	10	0
3	63	7.06	5.75	6.73	0	4.26	1.51	8.32	8.74	7.85	10	7.65	10	4.46	6
4	96	10	10	10	10	7.53	10	10	10	10	10	10	10	10	10

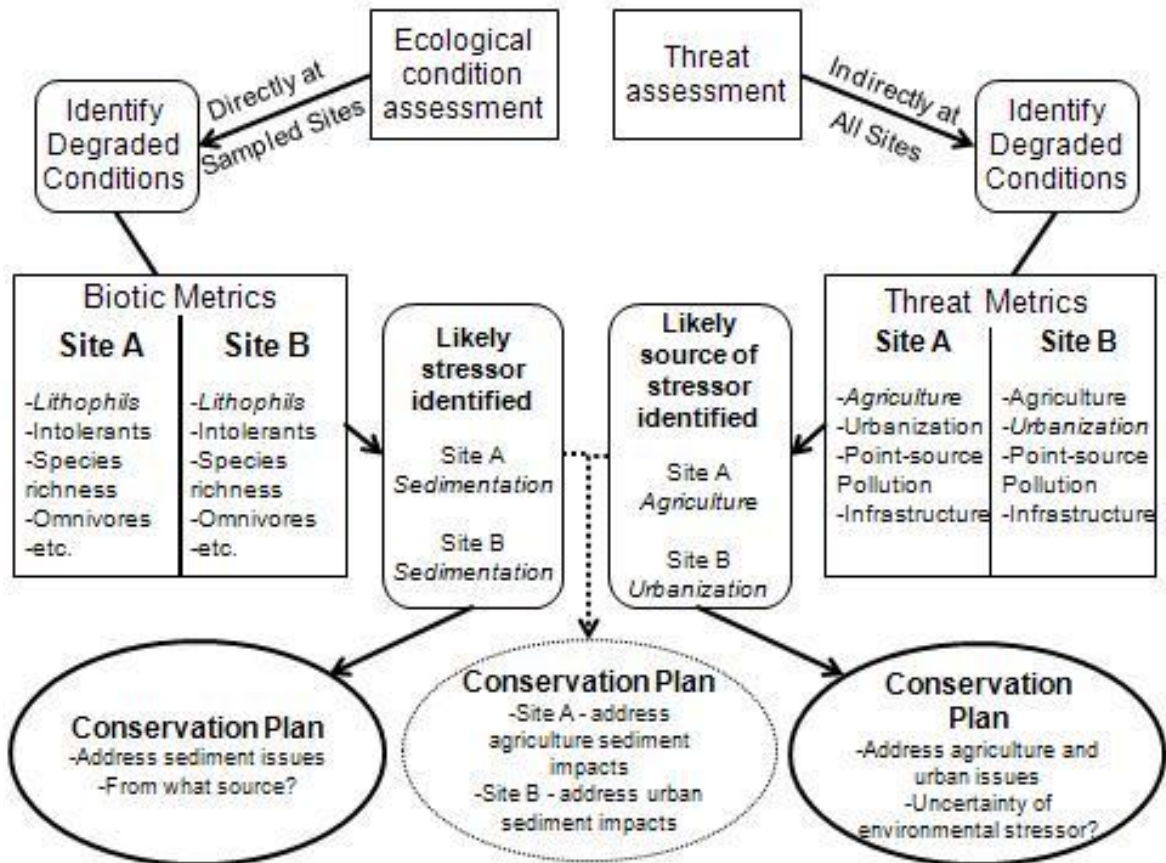

Figure 2.1. Conceptual diagram illustrating potential decision pathways and outcomes of conducting ecological condition and threat assessments. Solid arrows represent the alternative decision paths resource managers could follow when conducting each assessment independent of the other. Dotted arrows and borders represent decision pathways and potential assessment outcomes when ecological condition and threat assessments are coupled. Italic font represents intermediate outcomes of the decision path (e.g., lithophils were identified as limiting biotic integrity in the ecological condition assessment).

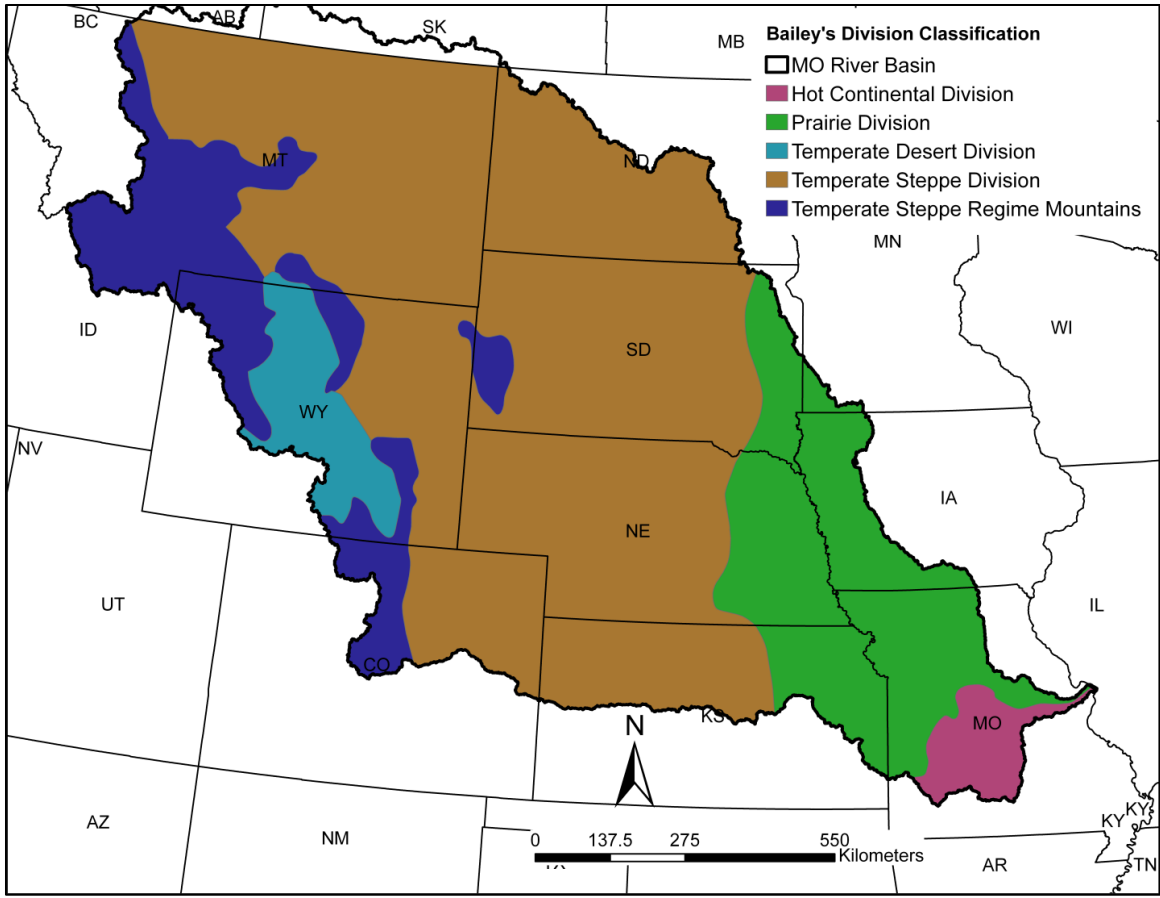

Figure 2.2. Map of the Missouri River basin and Bailey's (1983) division classifications.

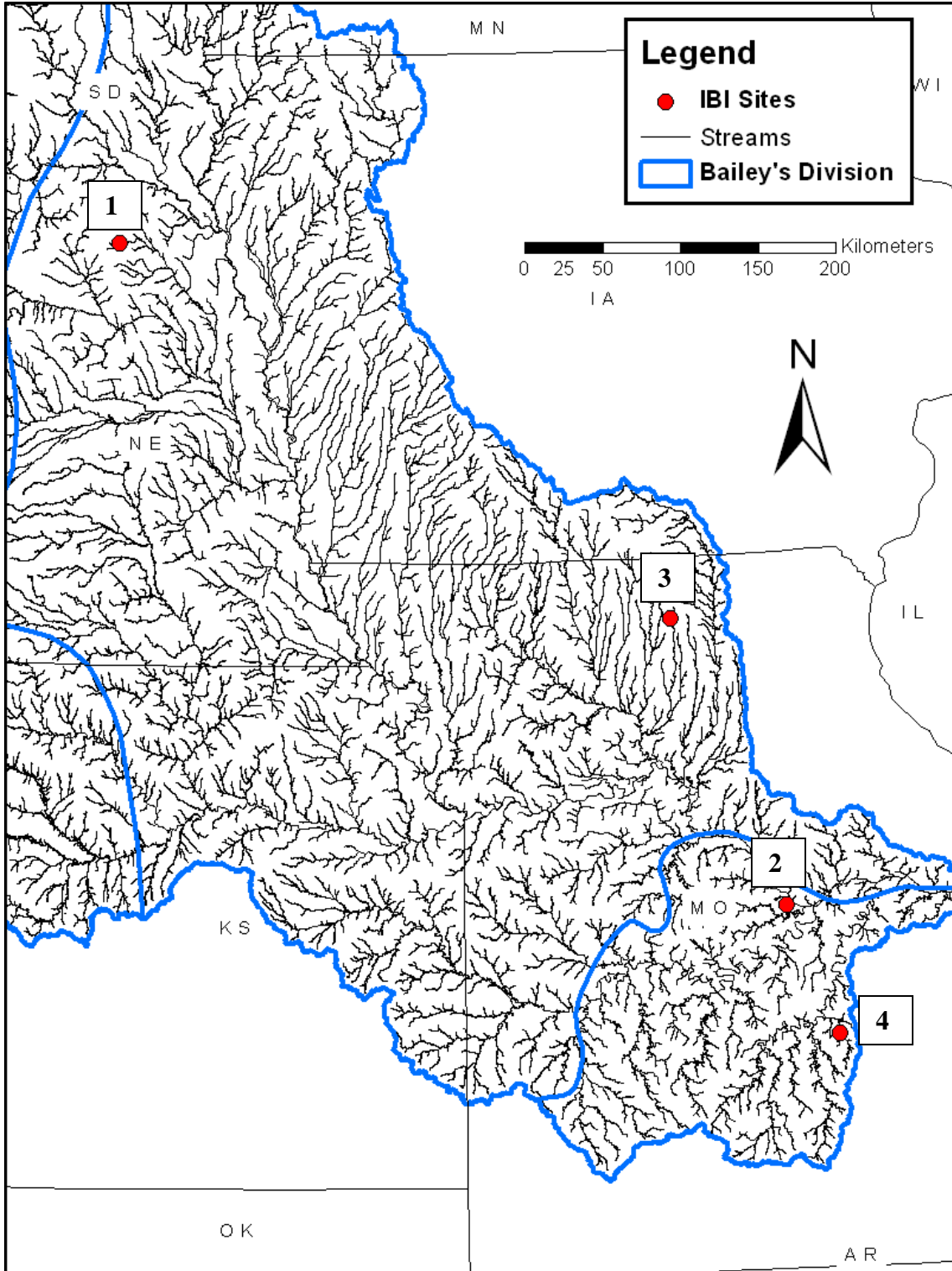

Figure 2.3. Map depicting four stream sites within the Missouri River basin where fish index of biotic integrity scores were computed. Numbers on map depict site numbers that are referenced in text. Refer to Tables 2.4 for index of biotic integrity scores and Table 2.5 for individual IBI metric scores.

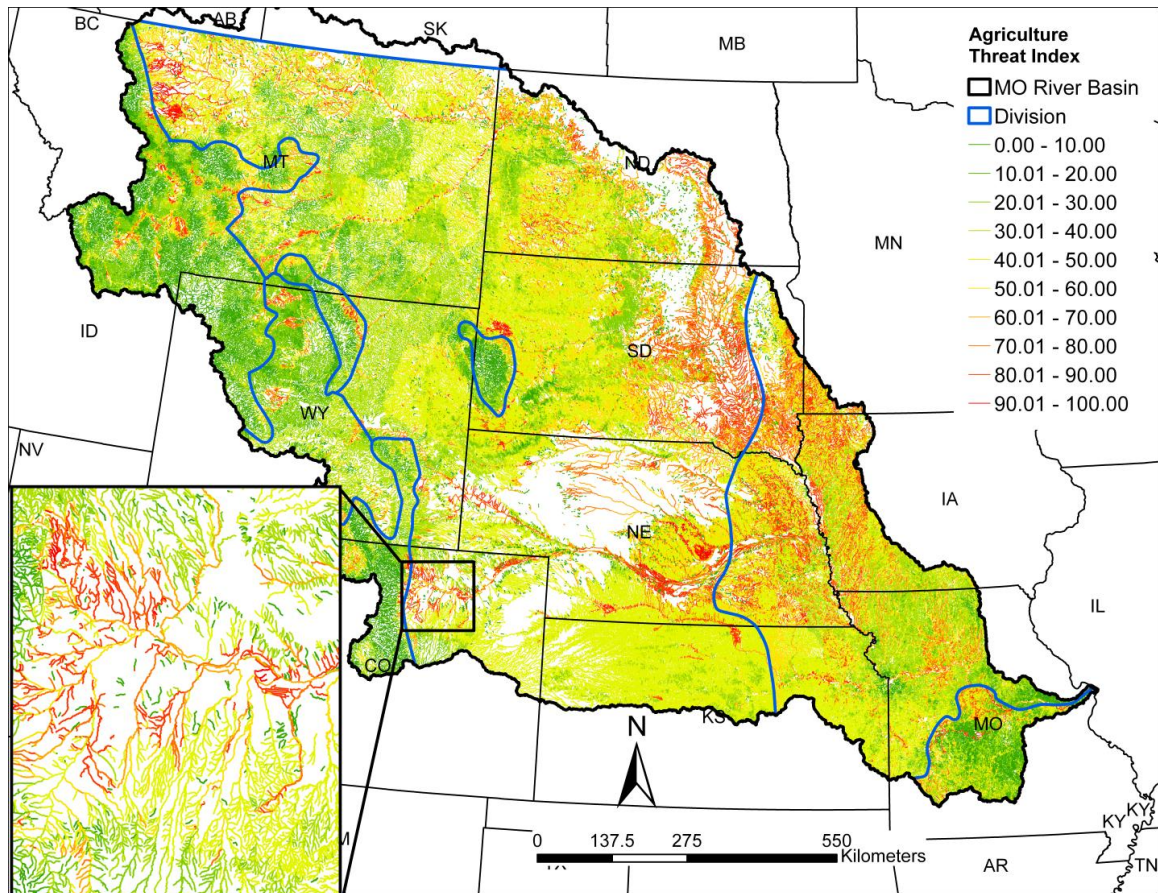

Figure 2.4. Map of the agriculture threat index scores (target threats) for every stream segment within the US portion of the Missouri River basin. Threat index scores were calculated using threat prevalence information quantified for every stream segment's upstream watershed area. Threat index scores were calculated separately for each division classification (see Figure 2.2). Maximum threat scores are relative to the most threatened stream segment in each division.

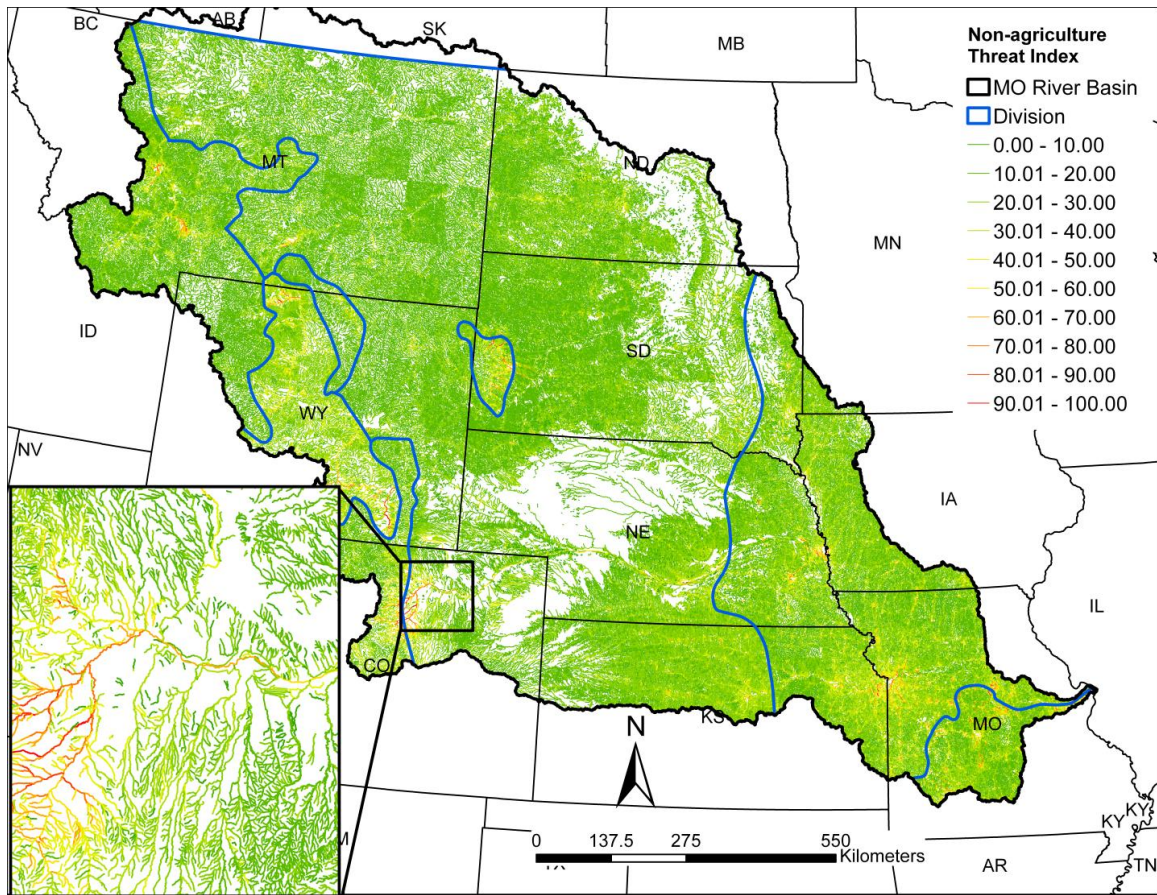

Figure 2.5. Map of the non-agriculture threat index scores (non-target threats) for every stream segment within the US portion of the Missouri River basin. Threat index scores were calculated using threat prevalence information quantified for every stream segment's upstream watershed area. Threat index scores were calculated separately for each division classification (see Figure 2.2). Maximum threat scores are relative to the most threatened stream segment in each division.

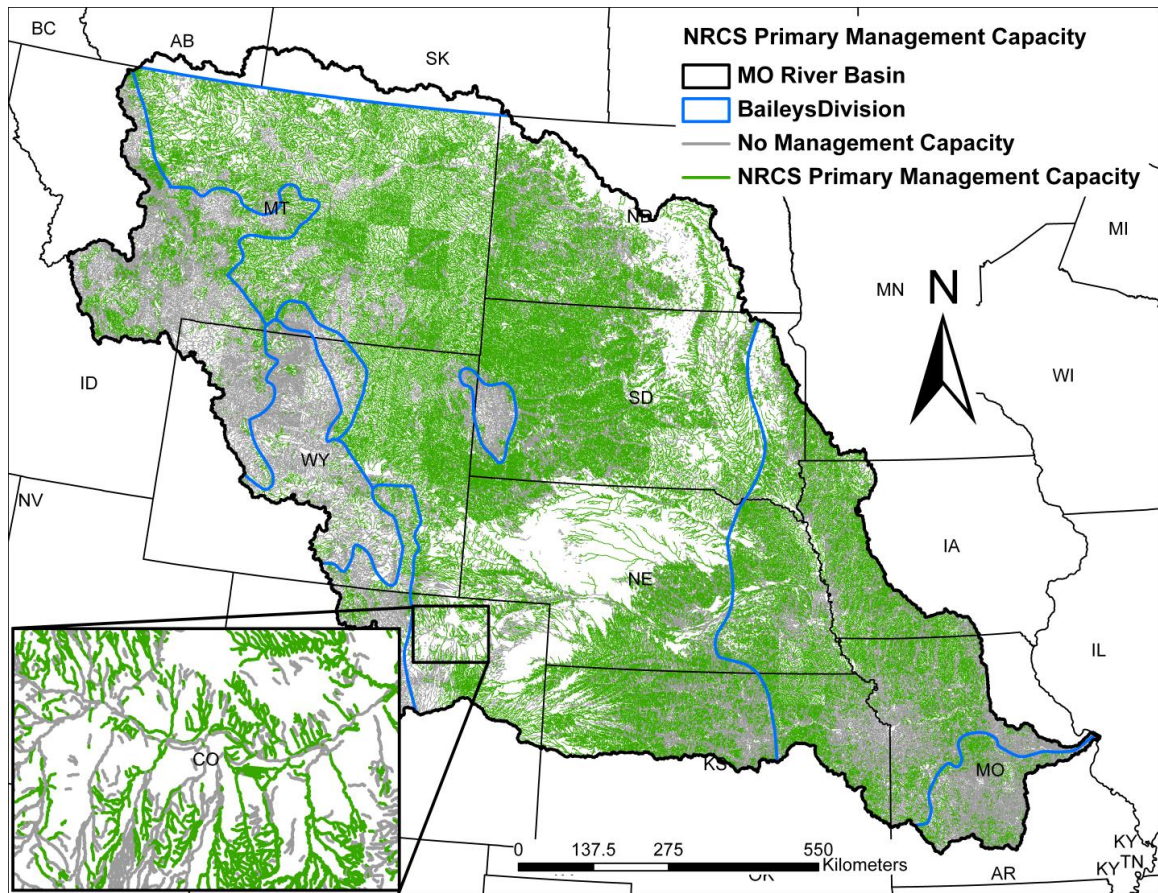

Figure 2.6. Map of NRCS primary management capacity for every stream segment within the US portion of the Missouri River basin. Streams with management capacity scores ≥ 2 (see text and Table 2.2) were considered to be under NRCS management capacity.

CHAPTER 3 - EFFECTIVENESS OF NRCS AGRICULTURE CONSERVATION PRACTICES ON STREAM FISH ASSEMBLAGES

Abstract

Improving fish conservation in agricultural landscapes requires a better understanding of where conservation practices (CPs) have been effective, the types of CPs that will improve conservation, and the density of CPs needed to achieve conservation goals. This research assesses agricultural soil CPs intended to address soil erosion and sedimentation issues that are implemented through the U.S. Department of Agriculture Natural Resources Conservation Service's (NRCS) assistance based on their effectiveness at improving fish assemblages across the Missouri River basin. Multiple-regression modeling for individual stream segments was used to predict the watershed-scale effects of physiography, human threats, and agriculture CPs on the guild abundance of fish reproductive and trophic guilds sensitive to sedimentation. Models were used to predict two scenarios of guild abundance for each stream segment where: 1) base condition of guild abundance assuming no CPs were implemented and 2) a conservation condition guild abundance which incorporated the effects of currently implemented NRCS CPs applied from 1999 - 2008. Lithophilous spawning guilds were positively associated with NRCS CPs, which indicated that CPs have the potential to effectively address agricultural sources of stream sedimentation. Conversely, omnivores were negatively correlated with NRCS CPs indicating trophic diversity may increase with implementation of CPs. CPs were considered effective for a stream segment if base fish

assemblage conditions were predicted to be ‘more disturbed,’ and fish assemblages in the conservation condition associated with applied CPs were predicted to be ‘less disturbed.’ Models indicated that applied CPs were expected to be effective in less than 2% of the Missouri River Basin stream segments we assessed. A watershed generally needed more than 50% of its area treated with NRCS soil conservation practices for CPs to be effective at improving fish assemblages and the observed lack of effectiveness was primarily in watersheds having significantly less than 50% coverage of these practices. Because conservation resources are limited, and the density of CPs needed to be effective is so high, successful fish conservation in agricultural landscapes will require managers to prioritize watersheds where CPs can be implemented in great enough density to reach ecological conservation goals.

Chapter 3 - Summary of Management Opportunities, Use Limitations, and Improvement Options for Analyses Used to Assess Effectiveness of NRCS Agriculture Conservation Practices on Stream Fish Assemblages

Opportunities for Using Conservation Practice Assessment

- Assess past and prioritize future implementation of NRCS CPs at multiple spatial scales to identify stream reaches:
 - where agricultural conservation is likely not needed, but maintenance of current conditions is necessary.
 - where fish assemblages are likely to be below reference conditions, but non-agricultural conservation is needed.
 - where past or existing CPs have likely improved fish assemblage condition and maintenance of current practices is needed.
 - and prioritize where fish assemblages are likely to be below reference conditions and restorative agricultural CPs are needed.
 - Quantify the amount of CPs likely needed to change guild abundance to targeted conservation levels (e.g., reference condition).

Limitations and Caveats of the Conservation Practice Assessment

- Applied CPs were assumed fully functional upon implementation.
 - the models do not account for potential temporal lags in CP effects to physical habitats and biological communities.
- Applied CPs were assumed to meet all goals outlined in the NRCS national practice standards.
- The fish guild abundance values used to represent reference conditions may or may not accurately reflect the expected conservation outcomes of NRCS or another of the resource management agency.
- Model predictions should not be extrapolated outside of the ecoregions in which they were developed.
- Conservation practices not cost-shared by NRCS were unrepresented in our datasets.

Options for Improvement

- Field-based validation should be conducted to determine actual CP effectiveness (the models and their resulting predictions were statistically validated).
- Record applied NRCS practice data to reflect actual boundaries and footprint of CPs (as opposed to points) to increase accuracy of watershed-level prevalence estimates.
- Account for the type and amount of applied CPs **not** cost-shared through NRCS to more accurately represent agricultural conservation efforts.
- Increase spatial coverage of fish sampling data.
 - more samples from least disturbed streams.
 - samples that span the entire density gradient of agricultural CPs.
- Incorporate additional biological endpoints (e.g., macroinvertebrates) in future analyses of CP effectiveness.
- Evaluate the temporal lag associated with biotic response and CP implementation.

Introduction

Fish conservation efforts are increasingly being conducted over large spatial extents (NFHAP 2006), which requires managers to use conservation resources in a manner that maximizes the potential for success. Aquatic ecologists have long recognized and called for a watershed approach to fish management (Moyle and Yoshiyama 1994) because it recognizes the importance of landscape constraints on fish assemblage structure by identifying limiting factors at multiple spatial scales (Poff 1997). Using this approach, managers can identify threats causing ecological degradation, determine appropriate conservation practices (CPs) to implement, and identify specific watersheds to focus their conservation efforts. However, watershed assessments designed to determine the factors responsible for ecological degradation are generally not conducted prior to conservation/restoration activities, and sites are generally selected based on opportunity (i.e., availability of land) instead of ecological need (Alexander and Allan 2006; Alexander and Allan 2007).

Stream sedimentation is regarded as the largest threat to U.S. streams because of its impact on physical habitats and its direct effects to biota (US Environmental Protection Agency 2000b; Waters 1995; Wood and Armitage 1997). The primary cause of soil erosion and stream sedimentation in the Midwestern U.S. is poor agricultural practices (e.g., clean tillage or overgrazing) that result in excessive soil disturbance. Sedimentation from agriculture causes decreased channel and bank stability (Diana and others 2006; Infante and others 2006) and this leads to greater bank erosion and channel widening (Kondolf and others 2002). Fishes are good indicators of water quality and their trophic and reproductive traits are sensitive to sedimentation (Berkman and Rabeni 1987; Bramblett and others 2005; Sutherland and others 2002).

Because soil erosion is detrimental to stream ecosystems and farm production (including profitability), most agriculture CPs are designed to reduce soil erosion or prevent eroded sediments from entering streams. The potential for CPs to reduce erosion or prevent sedimentation is generally well understood and quantified (Schnepf and Cox 2006), but little is known of their ecological effectiveness. Agriculture CPs are generally found to be very effective at preventing erosion and reducing sediment loads in runoff with up to a 90% reduction in both (Reeder and Westermann 2006), but these effects are usually estimated in controlled experiments and are not always corroborated by field observations (Boesch and others 2001; Gregory and others 2007; Lemke and others 2011).

Most agriculture conservation in the U.S is funded through voluntary conservation programs authorized by recurring Farm Bills. The USDA Farm Service Agency administers the Conservation Reserve Program (CRP), whereby environmentally-sensitive croplands are temporarily taken out of production. The USDA Natural Resources Conservation Service (NRCS) administers several long-term easement programs (Wetlands Reserve Program, Grasslands Reserve Program, Farm and Ranchland Protection Program) and working lands conservation programs such as the Environmental Quality Incentives Program.

Farm Bill conservation programs are intended to improve environmental conditions, including wildlife habitat, in agricultural landscapes (Burger and others 2006; Gray and Teels 2006;). Benefits of agricultural conservation practices have been recognized and documented for terrestrial wildlife species. Enrolling land in the CRP and re-establishing grassland habitats has benefitted grassland bird populations and

production capacity of prairie-nesting ducks (Haufler 2005; Heard and others 2000). Benefits to a variety of birds and other wildlife have been documented from lands enrolled in the Wetlands Reserve Program and conservation practices applied on working agricultural lands (Haufler 2005; Heard and others 2000).

Less understood are the effects of NRCS conservation practices on lotic fish assemblages. Due to the widespread nature of agricultural threats, it will be critical to apply CPs on private lands to address soil conservation and stream sedimentation issues. However, research has indicated CP effectiveness can be variable when using fish assemblages as an indicator (Westra and others 2004; Zimmerman and others 2003). Therefore, fish conservation managers working in agricultural landscapes need a better understanding of where CPs have been effective, the types of CPs that provide ecological benefits, and the density of CPs needed to achieve the desired ecological effects.

Fish assemblages are important human resources (e.g., food and recreation) and are ideal water quality indicators well suited for investigating the effects of land management practices. Our premise is that effective soil CPs are those that reduce soil erosion and stream sedimentation, and in turn improve water quality and lotic fish assemblages. The goal of this research was to determine if NRCS CPs designed to reduce soil erosion or prevent sedimentation in agriculturally degraded streams and small rivers were ecologically effective, and to identify the types of CPs that were most effective. Soil conservation practices were considered *ecologically effective* in a watershed if their implementation (i.e., their presence and density) was predicted to shift streams from 'more' to 'less' disturbed conditions due to a presumed reduction in stream sedimentation as defined by reference condition values of fish guild abundance.

The goal was accomplished by completing two objectives:

- Assess CP effectiveness in streams and small rivers by using a multiple-regression modeling framework to account for the variation in fish reproductive and trophic guild abundance as a function of physiographic features and human threats.
 - Use the models to estimate how NRCS CPs affect fish guild abundance.
 - Determine for individual stream segments if currently implemented CPs were predicted to shift streams from ‘more’ to ‘less’ disturbed conditions
- Determine if CPs designed to prevent soil erosion were more effective than those designed to prevent eroded sediment from entering stream channels.

Human Threats and Their Influence on Fish Guild Abundance

Even though agriculture is the predominate threat to lotic systems in the Midwestern U.S., non-agricultural threats are generally heterogeneous across the landscape (Fore Chap. 2) and affect fish communities and overall ecological condition. Accounting for the effects of human threats to fish assemblages allows us to more accurately assess ecological degradation by improving the accuracy of estimating fish guild abundance. Urban threats tend to be spatially localized but can dramatically affect biota and alter physical habitats due to changes in hydrology (Roy and others 2005), increased sedimentation (Wolman and Schick 1967), and from point-sources of pollution (Hatt and others 2004; Young and Thackston 1999). Low densities of urbanization (generally 10% of watershed) have been shown to alter fish communities and ecological integrity (Wang and others 2000; Wang and others 2001; Weaver and Garman 1994).

Point-sources of pollution are generally located near urban areas, with the notable exception of mining activities, and can directly kill or displace aquatic biota. Finally, infrastructural threats such as dams and road crossings directly alter physical habitats and often fragment stream networks (Bouska and others 2010; Kondolf 1997; Ligon and others 1995; Poff and others 2007).

Fishes as Ecological Indicators

Fishes and the ecological guilds they belong to are ideal indicators of water quality (Karr 1981; Schmutz and others 2000). When selecting indicators of ecological degradation it is important to choose indicators that provide early warnings of ecological degradation, are appropriate to the spatial scale, are sensitive to a wide range of multiple stresses, are socially relevant, and indicate the cause of ecological change (Cairns 2003; Carignan and Villard 2002). Though aquatic macroinvertebrates are often used as ecological indicators (Berkman and others 1986), we used fishes because macroinvertebrates are generally more related to reach-scale physical habitat features than watershed-scale features (Richards and others 1997). Reach-scale physical habitat features that influence macroinvertebrate communities are generally related to catchment-scale features (Hutchens and others 2009), but obtaining consistent reach-scale physical habitat data across our study area was impossible and prevented the use of macroinvertebrates as ecological indicators.

Fishes have long been used as ecological indicators (Angermeier and Schlosser 1987; Karr 1981) because they integrate all aspects of their physiochemical environment, which makes them sensitive indicators of multiple anthropogenic disturbances (Karr

1999; Karr and Chu 2000). Since fishes are long-lived (relative to invertebrates) and mobile they are useful indicators of watershed-level conditions and are symptomatic of both chronic and acute environmental degradation (Schmutz and others 2000). Additionally, the public relates to fishes as indicators of ecological condition (or water quality) because of their value as a food source and as a means of recreation; this relationship between human values and fish provides a means to effectively communicate to agricultural producers and the public.

It is difficult to compare fish assemblages across large spatial extents because some species have limited distributions and the potential species pool can differ among watersheds. Trait-based approaches have been developed to address these issues across broad geographical areas (Frimpong and Angermeier 2009). Fish species are placed in ecological guilds that represent functional traits (niches) that have been shown to be similarly related to habitat features independent of the species pool and can be used to describe environmental relationships over large spatial extents (Lamouroux and others 2002). Another advantage of using ecological fish guilds is that because they represent functional traits of a community, the guild's abundance can be linked to physical drivers or processes (e.g., sedimentation) (Poff 1997). Ideally, researchers would establish causal mechanisms between human threats and stressors and identify how they alter ecological processes. However, this is nearly impossible over large geographic areas because we lack complete spatial data coverage to identify those causal mechanisms. Instead, ecologists can establish linkages among threats to functional fish traits (and guilds) to identify the likely mechanisms that cause change in fish communities (Poff and Allan 1995).

Study area

The Missouri River basin drains about 1,371,017 km² of the United States and 25,100 km² of Canada (Galat and others 2005). Dominant land cover within the basin includes 25% cropland, 48% grassland/pasture, 10% forest, 11% shrub, 3% urban, 2% wetland, and 1% open water. The Missouri River basin contains five Divisions (Bailey 1980; Bailey 1983) used as ecoregions: 1) Temperate Steppe Regime Mountains, 2) Temperate Steppe Division, 3) Temperate Desert Division, 4) Prairie Division, and 5) Hot Continental Division (Fig. 3.1). The first three divisions are in the Dry Domain and the latter two are in the Humid Temperate Domain of Bailey's classification. The Temperate Steppe Regime Mountains are distinguished from the Temperate Steppe Division because they exhibit altitudinal zonation that would otherwise share the same climatic regime. The Temperate Steppe Division is semiarid with cold and dry winters, warm and hot summers, and with evaporation generally exceeding precipitation. Typical vegetation is short grasses growing in bunches with scattered shrubs (generally sagebrush) and sometimes low trees. Soils are generally Mollisols, with Aridisols in some areas. Temperate Desert Division is a continental desert climate of extreme aridity, averaging less than 200mm in annual precipitation. Vegetation consists mostly of sagebrush and soils are Aridisols low in humus. The Prairie Division is typically associated with climates in which soil and air temperatures are high in summer and soil moisture is insufficient for tree growth. Vegetation consists of tall grasses with subdominant broad-leaf herbs. Woody species are generally absent. Soils are Mollisols, rich in organic matter. The Hot Continental Division is characterized by hot, humid summers with cool winters. Dominant vegetation is deciduous forest with a low shrub

layer and an understory of herbs in early spring. Soils are primarily Inceptisols, Utisols, and Alfisols.

Methods

General Modeling Approach

Models were developed to assess how the implementation of NRCS CPs affected fish guild abundance in ecoregions of the Missouri River basin. Fish guilds were used as indicators of CP effectiveness because they provide a mechanistic linkage between land use practices and their stressors (e.g., sedimentation) and the effects of soil CPs. Because the primary stressor from agricultural activities is stream sedimentation, species abundance of lithophilous spawning fishes (those that deposit their eggs in substrate) was hypothesized to be positively related to NRCS CPs designed to reduce stream sedimentation (Rabeni and Smale 1995). The species abundance of omnivores (those that feed on both plant and animal materials) was hypothesized to be negatively associated with NRCS CP density as this guild is commonly used to indicate ecological degradation (Angermeier and Schlosser 1987; Hughes and others 1998; Karr and others 1986). If guilds were absent in stream segments within an ecoregion we first modeled their distribution (presence/absence) to improve the accuracy of the CP assessment. Accuracy was improved by excluding stream segments where the guild was predicted to be absent because the effects of soil CP on fish guild abundance was assessed only in stream segments where the guild was predicted to occur. The first steps of the CP assessment were to account for natural physiographic and human induced threat variation in guild abundance. We then evaluated how applied NRCS CPs were associated with guild abundance. Predicted changes in guild abundance as a result of CP implementation

were evaluated relative to reference condition abundance estimates to assess if NRCS CP implementation improved stream condition from ‘more’ to ‘less’ disturbed conditions.

Regional Applicability of Conservation Practice Assessment

All models were constructed independently for each Missouri River Basin ecoregion to control for potential differences in biological response to threats and CPs (Frimpong and Angermeier 2010). The CP assessment applies only to streams classified as smaller than medium rivers (maximum link magnitude was 500). Stream size was restricted because headwater and smaller streams are more intricately linked to hillslope processes and land use activities than larger rivers (Gomi and others 2002); i.e., small streams are arguably more impacted by sedimentation. Although large rivers are a product of their watershed and thus influenced by land use (Hynes 1975), they are generally more impacted by hydrologic and geomorphic alterations associated with impoundments, dam operations, and in-channel structures (e.g., wing dikes) (Galat and others 2005; Jacobson and Galat 2006; Ward and Stanford 1983).

Additionally, obtaining representative fish community samples in large rivers requires sampling several habitat types with multiple gears (Utrup and Fisher 2006), whereas small streams generally can be effectively sampled with only one gear (usually electrofishing equipment). Our fish sample data lacked information on gear types used to collect the samples and we were therefore not confident the fish community samples would be representative for large rivers.

Using Fish and Ecological Guilds to Assess Conservation Practice Effectiveness

Ecological fish guilds were used to evaluate the effects of soil CPs to fish communities. We used the lithophilous spawning fish guild because they are sensitive to stream sedimentation. Lithophils deposit their eggs in the substratum, and often bury eggs in nests, where they require clean flowing water to provide oxygen and remove wastes (Balon 1975). Therefore, lithophils are sensitive to sedimentation threats (Berkman and Rabeni 1987; Nerbonne and Vondracek 2001; Sutherland and others 2002) and are generally expected to decrease in abundance as the density of threats causing sedimentation increases. Since measurements of stream sediment loads are not readily available, evaluating the response of lithophils to threats that cause sedimentation provides an indirect but mechanistic approach to assess how assemblages are affected by sedimentation and CPs designed to reduce sedimentation.

Fish trophic guilds are often used as indicators of biotic integrity (Angermeier and Karr 1986; Wang and others 1997) because macroinvertebrate communities and the fishes that specialize on foraging for macroinvertebrates are affected by stream sedimentation (Berkman and Rabeni 1987; Rabeni and others 2005; Waters 1995). Omnivorous fishes have been demonstrated to be an effective indicator of biotic integrity as they are typically more abundant at higher levels of environmental degradation (Bramblett and Fausch 1991; Fausch and others 1984; Karr 1981). This is most likely associated with the exclusion or reduced abundance of feeding specialists (e.g., benthic invertivores) as sedimentation and other stressors increase.

Modeling Fish Guild Distribution

We were primarily concerned with the response (increases or decreases) of indicator guild abundance to NRCS CPs in our CP assessment. However, guilds are often absent in streams as a function of physiographic features and human threats. In one ecoregion, the lithophil guild was commonly absent and we determined that our CP assessment models were not robust enough (they inaccurately predicted guild abundance) to account for the complex relationship among guild absence, physiographic features, human threats, and CPs. Upon further examination and by using a more robust modeling approach, we determined that the distribution (presence/absence) of the lithophil guild was influenced by complex interactions of physiography and human threats that our CP assessment model could not account for. We then used the distribution model to predict lithophil guild presence/absence across the ecoregion. Since lithophil guild distribution was not affected by CPs, we parameterized the CP assessment model with samples where the guild was present, as this allowed us to increase accuracy of the guild abundance predictions. Additionally, the CP assessment was not applied to stream segments where the distribution model predicted the guild to be absent. The CP assessment was then conducted by using a three-step multiple-regression modeling approach to estimate the effects of physiography, human threats, and NRCS CPs on fish reproductive and trophic guild abundance.

Physiography and its Influence on Fish Guild Abundance

The effects of physiographic features on fish guilds were accounted for in our models to account for the ‘natural’ variation in fish guild abundance. Surficial geology

and soil characteristics influence hydrology by affecting water infiltration rates and their mineral contents determine water chemistry (Allan and Castillo 2007; Charlton 2008; Cronan and others 1998; Hynes 1975). The rock fragment in soil can determine streambed materials and influences stream hydrology. Similarly, bedrock influences stream channels by constraining reaches and affecting hydrology (Charlton 2008). These factors are useful to describe variation in fish assemblage structure and should increase accuracy of guild abundance predictions (Helms and others 2009).

Datasets

This project relied on four major datasets: Fish Samples, Physiography, NRCS CPs, and Threat Indices. All data were georeferenced and, where applicable, the prevalence of each variable in the dataset was computed for every stream segment's (maximum link magnitude = 500) entire watershed and local contributing area. Three of the four datasets merit explanation below and information about the threat indices can be found in Fore (Chap. 1).

Fish Samples

Georeferenced fish samples were gathered from various state agencies and the Missouri River Basin Aquatic GAP project (Annis et al., unpublished data). Because the purpose for each fish collection and the sampling methodologies were unknown for each sample, we assumed that a sample with at least two species represented a community collection. Samples with less than two species were omitted from all analyses and were assumed to represent collections targeted for a specific taxon. All fish samples were

spatially joined to the stream segment data-layer (described in *Geographic Framework* section below) and summarized to represent species presence.

Using the FishTraits database developed by Frimpong and Angermeier (2009), fish species from each sample were classified into reproductive and trophic guilds. The FishTraits database was used because it provides a consistent classification of traits for all North American freshwater fish species. Reproductive guilds classifications are those of Balon (1975). Briefly, fish species are classified as non-guarders, nest guarders, and bearers. Within each of those groups, fish species are classified by their spawning behavior (e.g., lithophilous or phytophilous spawning) with each behavior assumed to be evolutionarily derived. We evaluated non-guarding, lithophilous spawners that utilize brood-hiding behaviors (group A.2.3). The non-guarding behavior was chosen because fish that guard nests have the ability to remove accumulated sediments from the nest and increase nest success; i.e., they are less sensitive to sedimentation.

Fish species are not classified into trophic guilds in FishTraits. Instead, the foraging strategies utilized by each species are reported and the user is responsible for designating trophic guilds. In this project, fish species were classified as omnivores if they consumed both animal and plant materials, regardless of their feeding position in the water column (any combination of FishTraits fields: FSHCRCRB or INVLFVFSH or EGGS and ALGPHYTO or MACVASCU or DETRITUS and BENTHIC or SURWCOL; Frimpong and Angermeier 2009).

The guild abundance of each reproductive and trophic guild was calculated for each sample as the proportion of species recorded in a guild out of the total number of species in the sample. The fish sample dataset was then split for each ecoregion into a

‘training’ dataset by randomly selecting 75% of the samples and a ‘test’ dataset using the remainder. The training data were used for regression model parameterization, and the test data were used to validate the models.

Physiography

Physiographic features were quantified in Missouri River basin to account for their influence on fish distributions (Sowa and others 2006; Steen and others 2008). Physiographic variables used were surficial geology, soil texture, depth to bedrock, percent rock-fragment in soil, and soil hydrologic group. Data were obtained from the Missouri River Basin Aquatic GAP project (Annis and others, unpublished data).

Physiographic variables were summarized using categorical principal components analysis (CPCA) to reduce the number of variables used for modeling. The physiographic variables were not appropriate to use in normal (linear) PCA because either watershed densities of each variable tended to be absent or near 100%; therefore, the variables were better described on an ordinal scale. Categorical principal components analysis does not assume linearity between variables and primarily differs from normal PCA because the correlation matrix is not used (Linting and others 2007). Instead, CPCA uses an optimal scaling approach to quantify newly created categorical variables that account for as much variance in the original variables as possible. The CPCAs were conducted in the SPSS CATPCA program. Physiographic variables were discretized into 10 ordinal categories in an approximately normal distribution. Principal components were retained if their eigenvalue was greater than one, and they accounted for more than

or equal to 10% of the variance. Principal component scores were computed for each stream segment and used in model parameterization.

Four principal components were retained for the Hot Continental Division and these explained 75% of the variance in physiography among all stream segments (Table 3.1). Principal component one was interpreted as a gradient of streams with watersheds containing soils with moderately low runoff potential to watersheds with deeply weathered loess, no rock fragment in the soil, and soils with moderately high runoff potential. Principal component two was interpreted as a gradient of watersheds with soils having moderately low runoff potential to watersheds with red clay. Principal component three was a gradient of 10-20% rock fragment in the watershed to 0-10% rock fragment in the watershed. Floodplain and alluvium terraces and fine texture soil loaded positively on principal component four (Table 3.1).

Four PCs were retained in the Prairie Division that explained 75% of the variance in physiography among all stream segments (Table 3.2). Soils of moderately low runoff potential loaded positively on principal component one. Principal component two was a gradient of medium soil texture to medium fine soil texture. Pre-Wisconsinan drift and soils with high runoff potential loaded negatively on principal component three, while Wisconsinan loess and soils with moderately high runoff potential loaded positively. Pre-Wisconsinan drift loaded positively on principal component four and soils with high runoff potential loaded negatively (Table 3.2).

NRCS Conservation Practices

Georeferenced NRCS CP data were obtained for Missouri River basin. The dataset included records of practices applied between 1999 and 2008 and the amount of practice installed [area (ha), number (no), or length (m)] at each point location. Each practice instance and its amount applied were attributed to the local catchment polygon that contained the practice. Practices were considered duplicates and omitted if they were implemented for multiple years at the same location and in the same density. Watershed prevalence of each practice was calculated for every stream segment as described below in the *Geographic Framework* section. Conservation practices were assumed fully functional upon implementation, and remained implemented and functional over the entire 9-year period.

Conservation practices were classified in groups that reflected the primary purpose of each practice. Grouping practices was necessary because a large number of practice types had similar goals and effects, and their wide spatial distribution often resulted in poor overlap of individual practice types with fish samples. Additionally, evaluating each CP type could lead to excessive statistical errors in the regression models due to insufficient degrees of freedom and the potential to over-fit the model. The national practice standard (available at: <http://www.nrcs.usda.gov/wps/portal/nrcs/main/national/technical/alphabetical/ncps>) for each NRCS CP was reviewed to identify commonalities among practice types. Nearly all CPs were aimed at improving water quality by reducing or preventing Soil Disturbance (*SD*) that causes erosion, or by preventing Sediment from Entering stream Channels (*SEC*). There were two groups of SEC practices, and they differed by their measurement unit of implementation. All SD

practices were implemented in hectares and most SEC practices were applied in hectares (SEC-ha), but some were applied linearly and reported in meters (SEC-m). Therefore, all CPs related to soil conservation were classified into three groups, SD, SEC-ha, and SEC-m (Table 3.3). Soil disturbance practices differed from SEC practices because they were designed to reduce erosion (thus, stream sedimentation), whereas SEC practices were designed to prevent eroded sediment from entering stream channels. Although all three CP groups have the potential to improve water quality, primarily through reducing sediment loads to streams, each practice group was evaluated separately to assess if one group was more effective than another.

Records of most of the 185 practice types were too few (<1000 occurrences with some exceptions; or <0.0008 % of total number implemented) to warrant further analysis; therefore, a subset of commonly applied practices were identified for further analysis. Infrequently implemented practices were excluded because they did not overlap with a sufficient number of fish samples to warrant inclusion into the analysis. Twenty-nine types of soil CPs were applied frequently enough to conduct the CP assessment (Table 3.3). Five practice types with <1000 occurrences were included in the CP groups because they were similar to other practice types with >1000 occurrences (i.e., the outcomes of the practices were expected to be the same). The five practices and their similar counterparts were: 1) 329C (Ridge Till) similar to 329 (No-till), 2) 346 (Ridge Till) because of its potential to reduce erosion, 3) 390 (Riparian Herbaceous Cover) similar to 391 (Riparian Forest Buffer) in that they are both in riparian zones, 4) 658 (Wetland Creation), and 5) 659 (Wetland Enhancement) similar to 657 (Wetland Restoration). Practice 329c and 346 both involve ridge tillage but were placed in different CP groups

because no-till planting applies to 329c whereas no-till planting is not covered under 346; therefore, soil disturbance is not likely to be reduced in 346 (Table 3.3).

Human Threats

A threat assessment was conducted for all stream segments in the Prairie Division and Hot Continental Division. Threat indices representing agricultural, urban, point-source pollution, and infrastructural threats were constructed by calculating the total watershed prevalence for 17 threat metrics (Fore Chap. 2). A non-agricultural threat index was generated as an aggregate of the urban, point-source pollution, and infrastructural indices. Individual threat metrics were standardized relative to the watershed with the highest threat metric prevalence and were transformed to a common scale because prevalence units differed among metrics (Fore Chap. 2). Threat indices were calculated by summing their corresponding standardized threat metrics and were transformed to a common scale so that comparisons could be made across the indices (Fore Chap. 2).

Geographic Framework

The base stream layer was acquired from work done for the Missouri River Basin Aquatic Gap Project (Annis and others 2009b). These stream networks represent a modified version of the 1:100,000 National Hydrography Dataset (NHD) (U.S. Geological Survey and U.S. Environmental Protection Agency 2008). The primary modification of the NHD was the repair of gross underrepresentation of stream density in portions of the basin corresponding to select 1:100,000 scale topographic maps. The

resulting stream networks were processed to remove loops and braids within the network that caused problems with geoprocessing tasks of quantifying the prevalence of environmental factors throughout the Missouri River basin. We used 30-meter digital elevation models from the NHDPlus (U.S. Geological Survey and U.S. Environmental Protection Agency 2008) and ArcHydro Tools (ArcGIS 9.3, ESRI, Redlands, CA) to create corresponding local catchment polygons (i.e., the land immediately draining a stream segment) for each of the 464,118 individual stream segments in the resulting Missouri River basin stream network. The resulting stream segments and catchment polygons were used as the spatial framework for quantifying and mapping the individual physiographic variables and NRCS CPs for this project. Individual variable prevalence was quantified within each of the local catchment polygons. Customized Arc Macro Language (ESRI, Redlands, CA) programs were then used to sum all of these values for each stream segment's entire watershed (i.e., the local catchment and all upstream catchments that a segment drains). Summed values were then divided by the overall watershed area to quantify the prevalence per unit area or as proportion of watershed of each variable.

Specific Modeling Methods

Fish Guild Distribution Models

The presence/absence of each guild was predicted when a fish sample dataset contained fish samples where lithophil or omnivore guilds were absent. All models used guild presence/absence as the response variable with physiography and human threats used as predictor variables. Classification trees were used because they are a robust non-

parametric model that can elucidate high-order interactions and non-linear patterns in ecological data (De'ath and Fabricius 2000; Olden and Jackson 2002). Classification trees are not constrained by normality assumptions and can handle multiple data types (interval, nominal, and ordinal) at once. The models use a recursive partitioning algorithm to repeatedly split a response variable into mutually exclusive nodes as a function of the independent variables (De'ath and Fabricius 2000; Olden and Jackson 2002). The CRT algorithm was used to construct models because it is less susceptible to over-fitting. The other algorithms (primarily CHAID and exhaustive CHAID) allow multiple splits for each predictor variable and tend to split predictors at values that are not biologically informative. The CRT algorithm splits each predictor variable into two nodes. The Gini impurity measure was used to determine node splits because it attempts to maximize homogeneity in child nodes with respect to the response variable (i.e., obtain child nodes with a single response value) (SPSS 2007). Stopping criteria for the classification trees were: five levels, 25 observations per parent node (a node that can be further divided), and five observations per child node (a terminal node). The resulting classification tree was 'pruned' to avoid over-fitting the model (De'ath and Fabricius 2000). Pruning allows over-fit models to have nodes removed to produce a simpler tree that minimizes the difference in risk between the original and pruned tree (i.e., the standard error of the pruned tree is similar to the original tree). Finally, split-sample cross-validation was used to assess model accuracy. Approximately 75% of the data were used to parameterize the model, and the remaining data were used as the test dataset.

Conservation Practice Assessment Models

A set of candidate models were used in a three-step process to select a model that accounts for the effects of physiography, human threats, and NRCS CPs on species abundance of the selected indicator guilds. Models were developed independently for each ecoregion in Missouri River basin and were parameterized with a training dataset. All models were evaluated with Akaike's Information Criterion (AIC) following an information theoretic approach (Burnham and Anderson 2002). All models were compared to competing models within each selection step and to a null model containing an intercept only. First, a 'natural model' was constructed to account for the effects of physiography on guild abundance and tested against the null model. The best model had the lowest AIC score and the other model(s) were ranked by their difference in AIC scores ($\Delta_i = AIC_i - AIC_{\min}$). Models with $\Delta_i \leq 3$ were considered to have support and were further evaluated for plausibility by calculating Akaike weights

$$\omega_i = (\exp(-0.5\Delta_i) / \left(\sum_{r=1}^R \exp(-0.5\Delta_r) \right))$$

where R equals the number of competing models. A model with $\omega_i \geq 0.90$ was considered the best model i of R models. If the natural model was retained, the effects of human threats were accounted for by developing multiple 'threat models'. The threat models contained the natural model, and each model was a unique combination of human threat indices. The threat indices represented major stream disturbances: agriculture, urbanization, point-source pollution, infrastructure, and non-agricultural threats (Fore Chap. 2). If no single threat model had $\omega_i \geq 0.90$, there was evidence of competition among models, and the highest ranked threat models whose ω_i values summed to ≥ 0.90

were used to examine CP effects. Once the best threat model (or models) was identified, a ‘conservation model’ was developed by adding all NRCS CPs. If necessary, conservation models were developed with the group of top threat models and evaluated with the same criterion, $\omega_i \geq 0.90$. If no conservation model met this criterion, the models were averaged by weighting the parameter estimates to each model’s ω_i .

Using the test dataset, final regression models were tested for fit by examining how accurately they could predict observed species abundance values for each guild. Model accuracy was reported as the mean residual from test dataset.

Assessing Conservation Practice Effectiveness

The effectiveness of CPs was assessed for individual stream segments by using two guild abundance predictions from the multiple-regression model and by establishing a reference condition guild abundance. Using the final regression models for each guild and ecoregion, we predicted guild abundance under ‘base’ and ‘conservation’ conditions. Base condition abundance (BCA) was predicted assuming no CPs were implemented on the landscape, and conservation condition abundance (CCA) was predicted by accounting for applied NRCS CPs. These two abundance predictions were then compared to a reference condition abundance (RCA) to determine conservation practice effectiveness.

Reference condition abundance was calculated as mean guild abundance from fish samples in ‘less’ disturbed stream segments. Stream segments were considered ‘less’ disturbed if their agriculture and non-agriculture threat index scores were below the 50th percentile for each index. Stream segments with agriculture and non-agriculture threat index scores above the 50th percentile in one or more indices were considered ‘more’

disturbed. The 50th percentile was used because there were not enough fish samples in streams where more stringent criteria (e.g., 25th percentiles) could be used.

Stream segments were classified into four ‘conservation effectiveness groups’ that reflect the segment’s conservation need (i.e., in need of agricultural or non-agricultural conservation) and the likely success of NRCS CPs. *Conservation practice effectiveness* was defined as a stream segment that was predicted to shift from ‘more’ disturbed under base condition to ‘less’ disturbed under conservation conditions. The conservation effectiveness groups were:

- Likely that agricultural conservation not needed – under base conditions streams considered ‘less’ disturbed
- Likely that non-agricultural conservation needed – under base conditions streams considered ‘more’ disturbed and non-agricultural threats most prevalent
- Likely that agricultural CPs not effective – under base conditions streams considered ‘more’ disturbed by agricultural threats and too few CPs implemented to shift streams to ‘less’ disturbed under conservation conditions
- Likely that agricultural CPs effective – under base conditions streams considered ‘more’ disturbed by agricultural threats and under conservation condition streams considered ‘less’ disturbed

Criteria used to classify conservation practice effectiveness differed for each guild and ecoregion and are detailed in the *Assessment of Conservation Practice Effectiveness* section and Table 3.11. Percent change in predicted guild abundance from base to conservation condition was calculated to determine the relative degree guild abundance changed as a function of CP application. Positive percent change values in lithophil guild

abundance are indicative of CP effectiveness because lithophils were hypothesized to increase in abundance in response to CPs. Negative percent change values in omnivore guild abundance are indicative of CP effectiveness because they were expected to decline in abundance in response to CP implementation. Lastly, output for all CP assessments was mapped to visually examine patterns of CP effectiveness.

Results

There were over 1.2 million individual CPs application records treating 23,920,968 ha (59,108,713 ac) of land during the 9-year period included in our database. The conservation practice assessment was successfully completed in Hot Continental and Prairie Divisions. The assessment in Hot Continental Division was conducted with both lithophil and omnivore guilds. The assessment in Prairie Division was successfully conducted with the lithophil guild, but an accurate model could not be developed for the omnivore guild. Due to limitations of our fish sample data, we were unable to conduct a CP assessment in the Temperate Steppe Regime Mountains, Temperate Desert Division, and Temperate Steppe Division of Missouri River basin. The fish sample data from the Temperate Steppe Regime Mountains and Temperate Desert Division ecoregions did not overlap with areas where NRCS CPs were implemented; CPs were either absent or in less than 5% of the entire watershed for nearly all fish samples from these ecoregions. To appropriately assess the effects of NRCS CPs, fish samples need to uniformly overlap a continuous density gradient of CPs. NRCS CPs were not assessed in the Temperate Steppe Division because a model that accurately predicted guild abundance could not be developed.

Fish Guild Distribution Modeling

Lithophils and omnivores were present in all fish samples from Hot Continental Division (with the exception of two samples for lithophils); therefore, presence/absence could not be modeled. Both guilds were assumed to be present at all streams segments in the ecoregion.

The lithophil presence model in Prairie Division had a split-sample classification rate of 79% and more accurately predicted presence (classification rate = 87%) than absence (classification rate = 56%; Table 3.4). The first level of the classification tree split with principal component three indicating that soil hydrology and surficial geology explained the most variation in lithophil presence. Probability of presence was positively related to soils with moderately high runoff potential and Wisconsinan loess and probability of presence was negatively related to Pre-Wisconsinan drift and soils with high runoff potential (Fig. 3.2). The effects of explanatory variables on probability of presence in lower levels of the model cannot be generalized for the entire ecoregion because the effects for each subsequent level of the model are dependent on the criteria of the preceding level. Physiography had a large influence on probability of presence, as it was present in three levels of the model. Watershed area was negatively related to probability of presence and was the second most important predictor. Principal component one was negatively related to probability of presence and was in the second level of the model (Fig. 3.2). Probability of presence in these streams was positively associated with soils that contain no rock fragment and was negatively associated with soils containing 40-60% rock fragment and soils in hydrologic group B (moderately low runoff potential; Fig 3.2). Agriculture and human threats were negatively related to

probability of presence and were less influential than physiographic variables. This model was used to predict lithophil presence throughout Prairie Division.

Conservation Practice Assessment Modeling

For the lithophil assessment in Hot Continental Division, we identified guild abundance values of 0 and >0.55 to be outliers and they were excluded from the training data. There was some support for the natural model in Hot Continental Division and it was retained for further analysis to account for physiographic effects. As suggested by ω_i , there was competition among the top three threat models (Table 3.5) and as a result, three CP models were examined. AIC scores in Hot Continental Division suggested threats were better represented by quadratic terms rather than simple linear. Due to poor overlap of fish samples with SEC-m practices and because these data were not normally distributed, this practice group was not evaluated in the Hot Continental Division. There was evidence of competition between two CP models as they collectively carried 94% of the model weight (Table 3.5). A final model was produced by weighting (relative to their AIC model weights) and averaging the parameter estimates from the top two CP models (Table 3.6) (Burnham and Anderson 2002). SD and SEC-ha practices were positively related to lithophil abundance (Fig. 3.3; Table 3.6). Lithophil abundance was well predicted by the final model as 79% of the test data observations ($n = 43$) were predicted within ± 0.10 of their actual value; the mean residual was -0.022 and the standard deviation was 0.136 .

The omnivore natural model in Hot Continental Division carried enough ω_i to be retained in further analyses (Table 3.7). There was more support for quadratic effects of

threats than the linear effects. Due to competing threat models, three conservation models were examined. The most parsimonious conservation model was excluded because it had a low ω_i (0.06). The top two conservation models had a combined ω_i of 94% and they were averaged to produce a final model (Table 3.7). Agriculture threats and SD practices (Fig. 3.3) were positively associated with omnivore abundance (Table 3.8). SEC-ha practices were negatively associated with omnivore abundance (Fig. 3.3; Table 3.8). The model predicted 77% of the observations in the test dataset to within 0.10 of the actual value. The mean residual of omnivore abundance model for the test dataset was -0.0112.

The ω_i was large enough in PD to retain the natural factor model of lithophil abundance (Table 3.9). Quadratic effects for threats were better supported than linear effects. The global threat model (all threat indices) had the highest ω_i (0.64), but there was support for a second model that did not contain threats ($\omega_i = 0.17$; Table 3.9). Conservation practice effects were added to the top two threat models. There was support for two CP models so their parameter estimates were weighted and averaged to produce a final model (Table 3.9). SEC-ha practices were expected to have greater positive effects to lithophil abundance than SD practices (Fig. 3.3; Table 3.10). SEC-m practices were negatively associated with lithophil abundance (Table 3.10).

Assessment of Conservation Practice Effectiveness

NRCS CPs were evaluated to determine if applied practices were effective. (Note that the criteria we used to define CP effectiveness could [and should] be altered to reflect the needs of a different project or program and we present it here for its ease of

communication). Conservation practices were considered effective if conservation condition abundance improved from base condition abundance to a less disturbed condition. Using lithophils as an indicator in Hot Continental Division, less disturbed streams were delineated by agriculture threat index scores <30 , non-agriculture threat index scores <26 , and reference condition abundance was 0.38 (Table 3.11). Seventy percent of streams in Hot Continental Division did not likely need agriculture conservation and 19.5% of streams likely needed non-agricultural conservation (Table 3.12; Fig. 3.4). Nearly all streams in need of non-agricultural conservation were located near the Osage River where there is extensive development for recreation and Gasconade River where non-agricultural threats are more prevalent than agriculture. Agricultural conservation was likely needed in 11.6% of Hot Continental Division stream segments. Agriculture CPs were likely not effective in 11.05% of all Hot Continental Division stream segments (Table 3.12; Fig. 3.4). Agriculture conservation was not likely to be effective in 95% of the stream segments in need of agriculture conservation (Table 3.12; Fig. 3.4). Of these, about half had no CPs implemented in their watershed and CP density was very low in the remaining watersheds. Agriculture CPs were expected to be effective in 0.55% of all Hot Continental Division stream segments, while 4.75% of stream segments were likely in need of agriculture conservation (Table 3.12; Fig. 3.4). Stream segments where CPs were likely effective averaged a 67% increase in lithophil abundance and had significantly higher densities of CPs than the other effectiveness groups (Table 3.12; Fig. 3.5).

The reference condition abundance for omnivores in Hot Continental Division was 0.48 and the threat index criteria were the same as those used for lithophils (Table

3.11). The results from the omnivore assessment indicate that applied CPs were likely effective in a similar number of stream segments as was for lithophils. The omnivore assessment suggests that only 19% of stream segments were not likely in need of conservation and that 34% were likely to need non-agriculture conservation (Table 3.13; Fig. 3.6). About 46% of stream segments in Hot Continental Division were likely to need agricultural conservation, but current agricultural conservation was likely ineffective in 98% of stream segments in need (Table 3.13; Fig. 3.6). Similar to lithophils, 0.9% of stream segments in Hot Continental Division and 2% of stream segments where agriculture conservation was needed were likely to have effective agriculture conservation at the present time (Table 3.13; Fig. 3.6). Where agriculture CPs were likely to be effective, omnivore abundance declined an average of 24% (Fig. 3.7) and SEC-ha practices were, on average, in greater density than SD practices (Table 3.13).

The Prairie Division assessment suggested 74% of streams were not likely in need of agriculture conservation and 7% were likely in need of non-agriculture conservation (Table 3.14; Fig. 3.4); reference condition abundance for lithophils in this ecoregion was 0.24. Agriculture conservation was likely needed in 19% of all Prairie Division streams and current agriculture conservation was likely effective in 9% of those stream segments that needed it (1.7% of all Prairie Division streams; Table 3.14; Fig. 3.4). Lithophil abundance generally increased less than 25% in most Prairie Division streams, and very few were expected to have large increases (Fig. 3.5). Mean CP density was different among all practice types between the ineffective and effective agriculture conservation groups (Table 3.14). However, the density of SEC-m practices was most different among groups (Table 3.14).

Discussion

Guild Response to Conservation Practices

Trophic and reproductive fish guilds were useful ecological indicators. Key attributes of ecological indicators needed for this project were that indicators were distributed over large geographies, sensitive over a wide range of stressors, and indicated the likely cause of ecological change (Carignan and Villard 2002; Noss 1990). The lithophil and omnivore guilds were present over the entire assessment area with one minor exception. Lithophils were predicted to be absent in only 15% of stream segments in the Prairie Division, but were distributed broadly enough to conduct the assessment across the ecoregion. The multiple-regression models indicate that lithophils and omnivores were sensitive to multiple human induced ecological stresses. Use of ecological guilds provided a means to assess the likely stressor responsible for ecological degradation as the two guilds had opposing relationships to human threats that typically result in stream sedimentation (e.g., agriculture and urbanization) and CPs designed to reduce stream sedimentation.

Managing for fish assemblages diverse in trophic and reproductive traits requires implementing multiple types of CPs. NRCS CPs generally showed effects consistent with our hypotheses in Hot Continental Division. Lithophil guild abundance was positively related to SD and SEC-ha practices. A one unit (proportion of watershed) increase in SD practice watershed density was predicted by the model to result in a greater increase in lithophil abundance than the same increase in SEC-ha practices; although, effects of both practice groups were similar at the highest practice densities (Fig. 3.3). Our hypothesis that omnivore abundance in Hot Continental Division would

decline with implementation of CPs was variably supported. Interestingly, the predicted response of lithophil and omnivore abundance to SEC-ha practices nearly mirrored one another. This suggests that as SEC-ha practice density increases, omnivore abundance decreases by a similar proportion as lithophil abundance increases. Inconsistent with our expectation, omnivores had a positive association with SD practices. This seems to suggest that SEC-ha practices may be more effective than SD practices because both lithophil and omnivore guilds exhibited the hypothesized response. However, this relationship indicates that the lithophilous spawning species positively correlated with SD practices were omnivorous. Given that SD practices positively affected lithophils and omnivores, the reason the effects of SD practices appear stronger for lithophils is that their abundance is more affected by the addition of a few species than are omnivores. For example, adding three omnivorous lithophil species to an assemblage may increase lithophil abundance by 100%, but may only increase omnivore abundance by 33%, because omnivores are generally more species rich than lithophils. Therefore, in effect, SD practices are positively related to omnivorous lithophils and SEC-ha practices are positively related to lithophils that are specialist feeders (e.g., invertivores).

At low CP densities in Hot Continental Division, the models predicted guild abundance to slightly decline (Fig. 3.3). This was illustrated by the negative mean values of percent change from base condition abundance to conservation condition abundance. Guild abundance was predicted by the model to decline because the SD and SEC-ha practices were estimated with quadratic functions. It is unlikely that guild abundance actually declines when CPs were implemented at low density because the overall trend for guild abundance was to increase. Instead, it is more appropriate to view the decline in

guild abundance as the range, or a threshold, for which guild abundance will not be affected by CP implementation. Similarly, omnivores in Hot Continental Division were predicted by the model to slightly increase in abundance until SEC-ha practice density was 60% and then sharply decline. The range where omnivore abundance increases should also be interpreted as the range in which CPs have no effect on abundance.

Generally, CPs in Prairie Division were positively related to lithophil abundance. However, based on the model that predicts lithophil guild abundance, neither SD nor SEC-ha practices would be expected to appreciably increase lithophil abundance. If each practice type were implemented in a density of 100% of a watershed, lithophil abundance would be predicted to increase by 0.10. The small, model predicted increase in abundance could indicate that lithophil abundance is naturally low or that areas of high agriculture intensity undermine current conservation efforts. For example, a treatment watershed in Illinois had 95% of its stream length buffered, but had higher suspended sediment loads than a paired reference watershed with less buffering likely because of untreated sediment sources (Lemke and others 2011). The Prairie Division has the highest density of agricultural threats in Missouri River basin (Fore Chap. 2), and it may be unreasonable to expect large changes in guild abundance under such intense agriculture production. Surprisingly, there was a negative association between SEC-m practices and lithophil abundance. The majority of practices in the SEC-m group were terraces (practice code 600). Terraces are commonly implemented on sloped croplands to reduce erosion and excessive water runoff (Chow and others 1999; Gassman and others 2006; Reeder and Westermann 2006); they are generally effective and it seems unlikely that lithophil abundance would decline with their implementation. The likely

association of SEC-m practices with highly erodible lands is more likely responsible for their negative association with lithophil abundance, as highly erodible lands were not accounted for in the agriculture threat index. The negative relationships indicates that SEC-m practices may be ineffective at reducing soil erosion or that streams with SEC-m practices were so degraded that additional CPs are required to remediate the sedimentation issues. Alternatively, past land use practices that increased erosion on fields that are now terraced, may have influenced fish assemblage structure (Harding and others 1998).

Limitations and Improving Future Conservation Practice Assessments

Increasing the amount and types of available geospatial data would improve future CP assessments (Brenden and others 2006). The spatial coverage of fish sample data should include samples in watersheds with low agriculture and non-agricultural threats (e.g., least disturbed reference streams) and in watersheds where CPs were present, especially watersheds where CPs were implemented in high density. Addressing these issues would improve the accuracy of the models and ensure the entire spectrum of watershed characteristics are represented in the assessment.

It was possible that NRCS CP density was inaccurately estimated in some streams draining small catchments. This occurred because practice density was attributed to point locations, and when individual agriculture fields crossed local catchment polygon boundaries, we could not attribute the appropriate CP density to the neighboring catchment. Ideally, CPs would be georeferenced as polygons or lines, depending on how the practice is quantified, so that more accurate watershed densities could be calculated.

Future assessments could be improved by further research that addresses the assumptions used to conduct this assessment. The true density of all agriculture CPs was unknown because voluntarily implemented CPs were undocumented. Some estimates indicate 31% of producers adopt conservation tillage practices (similar to our SD group) and that adoption of practices increases if government assistance is provided (Soule and others 2000). Additionally, structural CPs (e.g., grassed waterways) are more likely to be adopted than practices that alter farm operations (e.g., no-till; Soule and others 2000). Documenting the prevalence of these practices will improve our understanding of ecological responses to CPs. For example, by incorporating a field-based mapping technique in the United States Agriculture Census, researchers could have a more accurate assessment of field-level management practices. Most CPs had multiple goals in their practice standards, and we assumed each practice met all goals outlined by the practice standard (e.g., a practice could be implemented to control nutrient runoff, sediment runoff, or both). Each practice was considered fully functional upon implementation (i.e., there was no lag time) and over the evaluation period. It seems plausible that many practices have the potential to be immediately effective, but ecological effects are seldom realized in short time frames (1 – 2 yrs) (Gregory and others 2007; Meals and others 2009). For example, conservation tillage practices have been shown to reduce erosion up to 90% (Reeder and Westermann 2006), but in an Illinois watershed there were no detectable changes in instream suspended sediment and nutrient export after seven years of CP implementation (Lemke and others 2011). Lag times associated with CP effectiveness could be from reworking stored channel sediment

(Nelson and Booth 2002) or from eroding banks (Burckhardt and Todd 1998; Zaimes and others 2004).

Conservation Practices Effectiveness

Conservation practices in Hot Continental Division, on average, improved fish assemblages more than CPs in Prairie Division. This was evident because stream segments in Hot Continental Division had larger percent changes from base condition abundance to conservation condition abundance than stream segments in Prairie Division. On average, stream segments in Prairie Division where CPs were considered effective had base condition abundance values close to reference condition abundance and did not require large abundance increases to be classified as effective. It is doubtful the criteria used to delineate ‘less’ and ‘more’ disturbed conditions were prohibitive to classifying stream segments as effective. The criteria used to delineate reference condition abundance values (mean guild abundance of sites below the 50th percentile for agriculture and non-agriculture threats) were less stringent than those generally used to define reference conditions (Palmer and others 2005) because we did not have enough fish samples from watersheds with low agricultural and non-agricultural threats. By using more stringent criteria (e.g., threat index scores below the 25th percentile), a greater number (or perhaps the majority) of watersheds would be classified as in need of agricultural conservation and managers would be faced with an increased number of watersheds on which to focus their efforts. For example, our criteria classified 74% of the streams segments as ‘not in need of conservation,’ even though streams in Prairie Division are some of the most agriculturally threatened in Missouri River basin (Fore

Chap. 2). This highlights the need to develop fish sample databases that cover a wide spectrum of disturbance gradients.

The most effective CPs should be those in the SD group because they prevent erosion from occurring by reducing soil disturbance and erosion. However, we observed SD had lower marginal effects than SEC practices in the Prairie Division, whereas SD practices had higher marginal effects in the Hot Continental Division. This result may reflect the relative condition of riparian habitats between the two ecoregions and indicate the importance of assessing CP effectiveness between ecoregions. Lower marginal effects of SD practices in the Prairie Division may indicate that the primary source of agricultural degradation occurred in lowlands and that grassed waterways, field borders, and riparian restoration type practices were needed. Conversely, the higher marginal effects of SD practices in the Hot Continental Division may indicate that riparian habitats were more intact than Prairie Division streams and that upland agricultural threats were the primary source of degradation. Given the prevalence of forested landcover in the Hot Continental Division, this is not surprising.

Due to the potentially additive effects CPs have on guild abundance, successful fish conservation in agriculture landscapes can be accomplished by implementing multiple types of CPs that prevent or reduce soil erosion and stream sedimentation. We commonly observed watersheds with multiple CP types implemented in individual agricultural fields and their combined effects were the primary reason we observed watersheds where agricultural conservation was effective. For example, a stream could benefit from riparian restoration and grassed waterways in no-till or reduced-till fields because the riparian zone and waterway practices can reduce sedimentation when erosion

occurs and they provide other ecological benefits (e.g., shading the stream to reduce temperature, protecting stream banks, and providing woody debris) (Gregory 1991).

The positive associations we observed among CP groups and lithophil guild abundance suggests that CPs can reduce sedimentation and result in ecologically meaningful water quality improvements. Though we could not directly measure sediment loading, the associations between SD CPs and fish guild abundance we observed likely corroborate the reported effectiveness of land retirement practices (Gilley and others 1997), conservation tillage practices (Matisoff and others 2002), and grazing management practices (Belsky and others 1999; Meehan and Platts 1978; Platts 1989; Trimble and Mendel 1995) at reducing erosion. Additionally, the associations observed between SEC-ha practices and fish guild abundance suggests CPs such as field borders, filter strips (Dosskey and others 2005; Dosskey and others 2002), cover crops (Hartwig and Ammon 2002), and riparian zone restorations (Broadmeadow and Nisbet 2004; Gregory 1991; Tingle and others 1998) prevent stream sedimentation and potentially provide ecological benefits.

NRCS CPs have the potential to improve fish assemblage condition based on their estimated effects, but our assessment indicates that current agriculture conservation efforts have often been ineffective. Most watersheds have critical areas that contribute a disproportionate amount of ecological stress, and not addressing these areas can nullify the effects of CPs implemented in other parts of the watershed (Matisoff and others 2002; Tripathi and others 2003). This may be why we observed that a large investment of CPs was necessary to affect guild abundance. Gassman et al. (2010) estimated that CP implementation reduced sediment delivery to an agricultural watershed by 50%, but

observed essentially no change in fish assemblage composition. Our study suggests that agriculture conservation would be more effective if CPs were implemented in more than 50% of a watershed's area. Conservation practices needed to be implemented in 30 to 50% of Wisconsin streams' watersheds to detect a measurable fish community response (Wang and others 2002). Zimmerman et al. (2003) predicted a 98% reduction in the number of days suspended sediment crossed the lethal threshold for fish and no reduction in sublethal days as a result of decreasing sediment loading by 84% with the implementation of permanent vegetative cover, conservation tillage, and riparian CPs in Minnesota streams. In another watershed under the same CP scenario, they predicted a 49% decrease in sediment loading, but it was not expected to reduce the number of lethal or sublethal sediment days.

Today's managers of agricultural landscapes face major challenges in improving water quality and ecological condition of lotic systems. Crop commodity prices are at an all-time high and are expected to remain there in the near-term (1-2 years), briefly decline, and remain at historically high levels (USDA 2012b). Producers are expected to take advantage of high commodity prices during 2012 and increase crop acreage by 4% (95.9 million acres) above 2011 levels and 9% above 2010 levels (USDA 2012a). As a result, many conservationists and agricultural managers expect a decrease in enrollment of agricultural CPs (notably the Conservation Reserve Program) (Lucht 2011; Peoples 2012). Additionally, it is possible that 2012 Farm Bill funding for agricultural conservation will absorb significant funding cuts in the future. If producers remove land from retirement programs such as Conservation Reserve Program and CP funding is reduced, how or to what degree will water quality be impacted? Results from this study

suggest significant amounts of additional agricultural lands need to be enrolled in CPs to improve water quality enough to impact fish communities and that current efforts have not likely resulted in improved ecological condition of most streams. This means that to maintain or improve current water quality conditions, managers of agricultural systems will likely have to do more (conservation and water quality improvement) with less (funding).

Managers who wish to increase ecological benefits in agriculture landscapes should prioritize and select watersheds to implement NRCS CPs (Walter and others 2007). Prioritization can be informed by using the models developed in this project to predict the effects of implementing CPs of various types to watersheds throughout a region of concern. Our models are useful for agricultural management programs because managers can identify the expected ecological condition (thus water quality) of streams and focus their efforts where conservation is most needed. For example, we identified over 17,000 stream segments (using the lithophil guild) where agricultural conservation is needed. Managers could strategically allocate conservation resources to those watersheds. The models can then be used to identify the ecological potential of each stream by estimating how implementation of CPs would affect guild abundance, which would allow them to determine if their CPs would have positive ecological effects. Perhaps most importantly, managers can use these models to determine the amount of CPs needed to increase guild abundance to meet a conservation goal (e.g., reference condition abundance). This is important because managers can justify and set targets for the minimum amount of land that needs to be enrolled in CPs within their target watersheds. Incorporating these elements into conservation decision-making processes

will improve the efficacy of CPs and is more likely to result in improved water quality and ecosystem function.

Ecosystem services (e.g., clean water, scenic views, and wildlife habitat) derived from agricultural lands are important to the American public (Hellerstein and others 2003), and future farm policies that address these values may increase the success and support for conservation. Multi-functional agriculture may be a way to sustain or increase farm profitability and meet environmental objectives (Boody and others 2005) as it involves diversifying commodity crops, reestablishment of wetlands and perennial vegetation, utilizing conservation tillage, and reducing fertilizer inputs. Because a large component of multi-functional agriculture is to derive non-market goods, implementing it across landscapes will require leadership from both national and local levels so that farmers and the public can develop and maintain a shared vision for agricultural landscapes (Bills and Gross 2005). Our models can aid in the implementation of agricultural conservation programs because they can provide information to both regional and local-scale managers. The broad groupings we used for NRCS CPs gives local-scale managers the flexibility needed to tailor agricultural conservation programs to the needs of rural communities and stakeholders within target watersheds. Assessing ecological need over larger regions allows national or regional level managers to more strategically allocate funding within regions where conservation is most needed (see Fore Chap. 4). Many of the soil CPs we evaluated can be used as a means to derive non-market goods by decreasing sedimentation to improve water quality and fish communities while allowing producers to maintain profitability on their lands (Jordan and others 2007).

References

- Alexander GG, Allan JD (2006) Stream Restoration in the Upper Midwest, USA. *Restoration Ecology* 14:595-604
- Alexander GG, Allan JD (2007) Ecological Success in Stream Restoration: Case Studies from the Midwestern United States. *Environmental Management* 40:245-255
- Allan JD, Castillo MM (2007) Stream ecology: Structure and function of running waters, 2nd edition. Springer, Dordrecht, The Netherlands, 436 pp
- Angermeier PL, Karr JR (1986) Applying an Index of Biotic Integrity Based on Stream-Fish Communities: Considerations in Sampling and Interpretation. *North American Journal of Fisheries Management* 6:418-429
- Angermeier PL, Schlosser IJ (1987) Assessing Biotic Integrity of the Fish Community in a Small Illinois Stream. *North American Journal of Fisheries Management* 7:331-338
- Annis GM, Sowa SP, Diamond DD, Combes MD, Doisy KE, Garringer AJ, Hanberry P (2009) Developing synoptic human threat indices for assessing the ecological integrity of freshwater ecosystems in EPA Region 7. Final report, submitted to Environmental Protection Agency, 192 pp
- Bailey RG (1980) Description of the ecoregions of the United States. 1391, U.S. Department of Agriculture, 77 pp
- Bailey RG (1983) Delineation of ecosystem regions. *Environmental Management* 7:365-373
- Balon EK (1975) Reproductive guilds of fishes: a proposal and definition. *Journal of the Fisheries Research Board of Canada* 32:821-864

- Belsky AJ, Matzke A, Uselman S (1999) Survey of livestock influences on stream and riparian ecosystems in the western United States. *Journal of Soil and Water Conservation* 54:419-431
- Berkman HE, Rabeni CF, Boyle TP (1986) Biomonitoring of stream quality in agricultural areas: Fish versus invertebrates. *Environmental Management* 10:413-419
- Berkman HE, Rabeni CF (1987) Effect of siltation on stream fish communities. *Environmental Biology of Fishes* 18:285-294
- Bills N, Gross D (2005) Sustaining multifunctional agricultural landscapes: comparing stakeholder perspectives in New York (US) and England (UK). *Land Use Policy* 22:313-321
- Boesch DF, Brinsfield RB, Magnien RE (2001) Chesapeake Bay eutrophication: Scientific understanding, ecosystem restoration, and challenges for agriculture. *Journal of Environmental Quality* 30:303-320
- Boody G, Vondracek B, Andow DA, Krinke M, Westra J, Zimmerman J, Welle P (2005) Multifunctional Agriculture in the United States. *BioScience* 55:27-38
- Bouska WW, Keane T, Paukert CP (2010) The Effects of Road Crossings on Prairie Stream Habitat and Function. *Journal of Freshwater Ecology* 25:499-506
- Bramblett RG, Fausch KD (1991) Variable Fish Communities and the Index of Biotic Integrity in a Western Great Plains River. *Transactions of the American Fisheries Society* 120:752-769
- Bramblett RG, Johnson TR, Zale AV, Heggem DG (2005) Development and Evaluation of a Fish Assemblage Index of Biotic Integrity for Northwestern Great Plains Streams. *Transactions of the American Fisheries Society* 134:624-640

- Brenden TO, Clark RDJr, Cooper AR, Seelbach PW, Wang L, Aichele SS, Bissel EG, Stewart JS (2006) A GIS framework for collecting, managing, and analyzing multiscale landscape variables across large regions for river conservation and management. In: Hughes RM, Wang L, Seelbach PW (eds), *Landscape Influences on Stream Habitat and Biological Assemblages*. American Fisheries Society, Symposium 48, Bethesda, Maryland, pp 49-74
- Broadmeadow S, Nisbet TR (2004) The effects of riparian forest management on the freshwater environment: a literature review of best management practice. *Hydrology and Earth System Sciences* 8:286-305
- Burckhardt JC, Todd BL (1998) Riparian Forest Effect on Lateral Stream Channel Migration in the Glacial Till Plains. *Journal of the American Water Resources Association* 34:179-184
- Burger Jr. LW, McKenzie D, Thackston R, Demaso SJ (2006) The Role of Farm Policy in Achieving Large-Scale Conservation: Bobwhite and Buffers. *Wildlife Society Bulletin* 34:986-993
- Burnham KP, Anderson DR (2002) *Model selection and multimodel inference: a practical information-theoretic approach*, 2nd edition. Springer, New York, New York,
- Cairns J (2003) *Biotic community response to stress*. CRC Press, Boca Raton, FL, pp 13-21
- Carignan V, Villard M (2002) Selecting Indicator Species to Monitor Ecological Integrity: A Review. *Environmental Monitoring and Assessment* 78:45-61

- Charlton R (2008) Fundamentals of fluvial geomorphology. Routledge, New York, New York, 234 pp
- Chow TL, Rees HW, Daigle JL (1999) Effectiveness of terraces/grassed waterway systems for soil and water conservation: A field evaluation. *Journal of Soil and Water Conservation* 54:577-583
- Cronan CS, Piampiano JT, Patterson HH (1998) Influence of Land Use and Hydrology on Exports of Carbon and Nitrogen in a Maine River Basin. *Journal of Environmental Quality* 28:953-961
- De'ath G, Fabricius KE (2000) Classification and Regression Trees: A Powerful Yet Simple Technique for Ecological Data Analysis. *Ecology* 81:3178-3192
- Diana M, Allan JD, and Infante D. The influence of physical habitat and land use on stream fish assemblages in southeastern Michigan. Hughes, Robert M., Wang, Lizhu, and Seelbach, Paul W. *Landscape Influences on Stream Habitats and Biological Assemblages*. 359-374. 2006. Bethesda, Maryland, American Fisheries Society, Symposium 48.
- Dosskey MG, Eisenhauer DE, Helmers MJ (2005) Establishing conservation buffers using precision information. *Journal of Soil and Water Conservation* 60:349-354
- Dosskey MG, Helmers MJ, Eisenhauer DE, Franti TG, Hoagland KD (2002) Assessment of concentrated flow through riparian buffers. *Journal of Soil and Water Conservation* 57:336-343
- Fausch KD, Karr JR, YANT PR (1984) Regional Application of an Index of Biotic Integrity Based on Stream Fish Communities. *Transactions of the American Fisheries Society* 113:39-55

- Frimpong EA, Angermeier PL (2009) Fish Traits: A Database of Ecological and Life-history Traits of Freshwater Fishes of the United States. *Fisheries* 34:487-495
- Frimpong EA, Angermeier PL (2010) Comparative Utility of Selected Frameworks for Regionalizing Fish-Based Bioassessments across the United States. *Transactions of the American Fisheries Society* 139:1872-1895
- Galat DL, Berry CR, Peters EJ, White RG (2005) Missouri River Basin. In: Benke AC, Cushing CE (eds), *Rivers of North America*. Elsevier, Oxford, pp 427-480
- Gassman PW, Tisl JA, Palas EA, Fields CL, Isenhardt TM, Schilling KE, Wolter CF, Seigley LS, Helmers MJ (2010) Conservation practice establishment in two northeast Iowa watersheds: Strategies, water quality implications, and lessons learned. *Journal of Soil and Water Conservation* 65:381-392
- Gassman PW, Osei E, Saleh A, Rodecap J, Norvell S, Williams J (2006) Alternative practices for sediment and nutrient loss control on livestock farms in northeast Iowa. *Agriculture, Ecosystems & Environment* 117:135-144
- Gilley JE, Doran JW, Karlen DL, Kaspar TC (1997) Runoff, erosion, and soil quality characteristics of a former Conservation Reserve Program site. *Journal of Soil and Water Conservation* 52:189-193
- Gomi T, Sidle RC, Richardson JS (2002) Understanding Processes and Downstream Linkages of Headwater Systems. *BioScience* 52:905-916
- Gray RL, Teels BM (2006) Wildlife and Fish Conservation Through the Farm Bill. *Wildlife Society Bulletin* 34:906-913
- Gregory S, Allen AW, Baker M, Boyer K, Dillaha T, Elliott J (2007) Realistic expectations of timing between conservation and restoration actions and

- ecological responses. In: Schnepf M, Cox C (eds), *Managing Agricultural Landscapes for Environmental Quality: Strengthening the Science Base*. Soil and Water Conservation Society, Ankeny, Iowa, USA, pp 115-146
- Gregory SV (1991) An ecosystem perspective of riparian zones. *BioScience* 41:540-551
- Harding JS, Benfield EF, Bolstad PV, Helfman GS, Jones III EBD (1998) Stream biodiversity: The ghost of land use past. *Proceedings of the National Academy of Sciences of the United States of America* 95:14843-14847
- Hartwig NL, Ammon HU (2002) Cover crops and living mulches. *Weed Science* 50:688-699
- Hatt BE, Fletcher TD, Walsh CJ, Taylor SL (2004) The Influence of Urban Density and Drainage Infrastructure on the Concentrations and Loads of Pollutants in Small Streams. *Environmental Management* 34:112-124
- Haufler, JB (2005) Fish and Wildlife Benefits of Farm Bill Conservation Programs: 2000-2005 Update. The Wildlife Society Technical Review 05-2, Bethesda, Maryland, USA
- Heard LP, Allen AW, Best LB, Brady SJ, Burger W, Esser AJ, Hackett E, Johnson DH, Pederson RL, Reynolds RE, Rewa C, Ryan M, Molleur R, Buck P (2000) A comprehensive review of Farm Bill contributions to wildlife conservation, 1985 - 2000. Technical Report WHMI-2000, U.S. Department of Agriculture, Natural Resources Conservation Service, Madison, Mississippi, USA
- Hellerstein D, Nickerson C, Cooper J, Feather P, Gadsby D, Mullarky D, Tegene A, Barnard C (2003) *Farmland Protection: The Role of Public Preferences for Rural Amenities*. 815, United States Department of Agriculture, 66 pp

- Helms BS, Schoonover JE, Feminella JW (2009) Assessing Influences of Hydrology, Physicochemistry, and Habitat on Stream Fish Assemblages Across a Changing Landscape. *Journal of the American Water Resources Association* 45:157-169
- Hughes RM, Kaufmann PR, Herlihy AT, Kincaid TM, Reynolds L, Larsen DP (1998) A process for developing and evaluating indices of fish assemblage integrity. *Canadian Journal of Fisheries and Aquatic Sciences* 55:1618-1631
- Hutchens JJr, Schuldt JA, Richards C, Johnson LB, Host GE, Breneman DH (2009) Multi-scale mechanistic indicators of Midwestern USA stream macroinvertebrates. *Ecological Indicators* 9:1138-1150
- Hynes HBN (1975) Edgardo Baldi memorial lecture. The stream and its valley. *Verhandlungen der Internationalen Vereinigung fur theoretische und angewandte Limnologie* 19:1-15
- Infante DM, Wiley MJ, Seelbach PW (2006) Relationships among channel shape, catchment characteristics, and fish in lower Michigan streams. In: Hughes RM, Wang L, Seelbach PW (eds), *Landscape Influences on Stream Habitat and Biological Assemblages*. American Fisheries Society, Bethesda, Maryland, pp 339-357
- Jacobson RB, Galat DL (2006) Flow and form in rehabilitation of large-river ecosystems: An example from the Lower Missouri River. *Geomorphology* 77:249-269
- Jordan N, Boody G, Broussard W, Glover JD, Keeney D, McCown BH, McIsaac G, Muller M, Murray H, Neal J, Pansing C, Turner RE, Warner K, Wyse D (2007) Sustainable Development of the Agricultural Bio-Economy. *Science* 316:1570-1571

- Karr JR, Fausch KD, Angermeier PL, Yant PR, Schlosser IJ (1986) Assessing Biological Integrity in Running Waters: A Method and its Rationale. Special Publication 5, Illinois Natural History Survey, Urbana, Illinois
- Karr JR (1981) Assessment of biotic integrity using fish communities. *Fisheries* 6:21-27
- Karr JR (1999) Defining and measuring river health. *Freshwater Biology* 41:221-234
- Karr JR, Chu EW (2000) Sustaining living rivers. *Hydrobiologia* 422-423:1-14
- Kondolf GM (1997) Hungry water: Effects of dams and gravel mining on river channels. *Environmental Management* 21:533-551
- Kondolf GM, Piégay H, Landon N (2002) Channel response to increased and decreased bedload supply from land use change: contrasts between two catchments. *Geomorphology* 45:35-51
- Lamouroux N, Poff NL, Angermeier PL (2002) Intercontinental Convergence of Stream Fish Community Traits along Geomorphic and Hydraulic Gradients. *Ecology* 83:1792-1807
- Lemke AM, Kirkham KG, Lindenbaum TT, Herbert ME, Tear TH, Perry WL, Herkert JR (2011) Evaluating Agricultural Best Management Practices in Tile-Drained Subwatersheds of the Mackinaw River, Illinois. *J. Environ. Qual* 40:1215-1228
- Ligon FK, Dietrich WE, Trush WJ (1995) Downstream Ecological Effects of Dams. *BioScience* 45:183-192
- Linting M, Meulman JJ, Groenen PJF, van der Koojj AJ (2007) Nonlinear principal components analysis: Introduction and application. *Psychological Methods* 12:336-358

- Lucht, G. 2011. Agriculture conservation program at crossroads. The Sioux City Journal.
Available: http://siouxcityjournal.com/business/local/agriculture-conservation-program-at-crossroads/article_f5983e41-3869-5dd1-af4e-63f93b207d0f.html.
(April 2012).
- Matisoff G, Bonniwell EC, Whiting PJ (2002) Soil Erosion and Sediment Sources in an Ohio Watershed using Beryllium-7, Cesium-137, and Lead-210. *Journal of Environmental Quality* 31:54-61
- Meals DW, Dressing SA, Davenport TE (2009) Lag Time in Water Quality Response to Best Management Practices: A Review. *Journal of Environmental Quality* 39:85-96
- Meehan WR, Platts WS (1978) Livestock grazing and the aquatic environment. *Journal of Soil and Water Conservation* 33:274-278
- Moyle PB, Yoshiyama RM (1994) Protection of Aquatic Biodiversity in California: A Five-tiered Approach. *Fisheries* 19:6-18
- Nelson EJ, Booth DB (2002) Sediment sources in an urbanizing, mixed land-use watershed. *Journal of Hydrology* 264:51-68
- Nerbonne BA, Vondracek B (2001) Effects of Local Land Use on Physical Habitat, Benthic Macroinvertebrates, and Fish in the Whitewater River, Minnesota, USA. *Environmental Management* 28:87-99
- NFHAP. 2006. National Fish Habitat Action Plan. Association of Fish and Wildlife Agencies, Washington, DC.
- Noss RF (1990) Indicators for Monitoring Biodiversity: A Hierarchical Approach. *Conservation Biology* 4:355-364

- Olden JD, Jackson DA (2002) A comparison of statistical approaches for modelling fish species distributions. *Freshwater Biology* 47:1976-1995
- Palmer MA, Bernhardt ES, Allan JD, Lake PS, Alexander G, Brooks S, Carr J, Clayton S, Dahm CN, Shah JF, Galat DL, Loss SG, Goodwin P, Hart DD, Hassett B, Jenkinson R, Kondolf GM, Lave R, Meyer JL, O'Donnell TK, Pagano L, Sudduth E (2005) Standards for ecologically successful river restoration. *Journal of Applied Ecology* 42:208-217
- Peeples, L. 2012. Farm Bill Conservation Programs Threatened By Anticipated Budget Cuts. *The Huffington Post*. Available: http://www.huffingtonpost.com/2011/12/11/farm-bill-environment-conservation-erosion-pollution_n_1142521.html. (April 2012).
- Platts WS (1989) Compatibility of livestock grazing strategies with fisheries. In: Gresswell RE, Barton BA, Kershner JL (eds), *Practical approaches to riparian resource management: an education workshop*. U.S. Bureau of Land Management, Billings, MT, pp 103-110
- Poff NL (1997) Landscape filters and species traits: Towards mechanistic understanding and prediction in stream ecology. *Journal of the North American Benthological Society* 16:391
- Poff NL, Allan JD (1995) Functional organization of stream fish assemblages in relation to hydrologic variability. *Ecology* 76:606-627
- Poff NL, Olden JD, Merritt DM, Pepin DM (2007) Homogenization of regional river dynamics by dams and global biodiversity implications. *Proceedings of the National Academy of Sciences* 104:5732-5737

- Rabeni CF, Doisy K, Zweig L (2005) Stream invertebrate community functional responses to deposited sediment. *Aquatic Sciences* 67:395-402
- Rabeni CF, Smale MA (1995) Effects of siltation on stream fishes and the potential mitigating role of the buffering riparian zone. *Hydrobiologia* 303:211-219
- Reeder RO, Westermann D (2006) Soil Management Practices. In: Schnepf M, Cox C (eds), *Environmental Benefits of Conservation on Cropland: The Status of Our Knowledge*. Soil and Water Conservation Society, Ankeny, IA, pp 1-87
- Richards C, Haro RJ, Johnson LB, Host GE (1997) Catchment and reach-scale properties as indicators of macroinvertebrate species traits. *Freshwater Biology* 37:219-230
- Roy AH, Freeman MC, Freeman BJ, Wenger SJ, Ensign WE, Meyer JL (2005) Investigating hydrologic alteration as a mechanism of fish assemblage shifts in urbanizing streams. *Journal of the North American Benthological Society* 24:656-678
- Schmutz S, Kaufmann M, Vogel B, Jungwirth M, Muhar S (2000) A multi-level concept for fish-based, river-type-specific assessment of ecological integrity. *Hydrobiologia* 422-423:279-289
- Schnepf M, Cox CA (2006) Environmental benefits of conservation on cropland: The status of our knowledge. Soil and Water Conservation Society, Ankeny, IA, 326 pp
- Soule MJ, Tegene A, Wiebe KD (2000) Land Tenure and the Adoption of Conservation Practices. *American Journal of Agricultural Economics* 82:993-1005

- Sowa SP, Annis G, Morey ME, Garringer A (2006) Developing Predicted Distribution Models for Fish Species in Nebraska. 00005007, The USGS National GAP Analysis Program, Moscow, ID 494 pp
- SPSS. SPSS Decision Trees 17.0. -146. 2007. Chicago, IL.
- Steen PJ, Zorn TG, Seelbach PW, Schaeffer JS (2008) Classification Tree Models for Predicting Distributions of Michigan Stream Fish from Landscape Variables. Transactions of the American Fisheries Society 137:976-996
- Sutherland AB, Meyer JL, Gardiner EP (2002) Effects of land cover on sediment regime and fish assemblage structure in four southern Appalachian streams. Freshwater Biology 47:1791-1805
- Tingle CH, Shaw DR, Boyette M, Murphy GP (1998) Metolachlor and Metribuzin Losses in Runoff as Affected by Width of Vegetative Filter Strips. Weed Science 46:475-479
- Trimble SW, Mendel AC (1995) The cow as a geomorphic agent -- A critical review. Geomorphology 13:233-253
- Tripathi MP, Panda RK, Raghuwanshi NS (2003) Identification and Prioritisation of Critical Sub-watersheds for Soil Conservation Management using the SWAT Model. Biosystems Engineering 85:365-379
- US Environmental Protection Agency (2000) Atlas of America's Polluted Waters. EPA 840-B00-002, Office of Water (4503F), United State Environmental Protection Agency, Washington, D.C.

- USDA (2012a) Prospective Plantings (March 2012). National Agricultural Statistics Service, Agricultural Statistics Board, United States Department of Agriculture , 36 pp
- USDA (2012b) USDA Agricultural Projections to 2021. OCE-2012-1, Office of the Chief Economist, World Agricultural Outlook Board, U.S. Department of Agriculture, 102 pp
- Utrup NJ, Fisher WL (2006) Development of a Rapid Bioassessment Protocol for Sampling Fish in Large Prairie Rivers. *North American Journal of Fisheries Management* 26:714-726
- Walter T, Dosskey M, Khanna M, Miller J, Tomer M, Wiens J (2007) The science of targeting within landscapes and watersheds to improve conservation effectiveness. In: Schnepf M, Cox C (eds), *Managing Agricultural Landscapes for Environmental Quality: Strengthening the Science Base*. Soil and Water Conservation Society, Ankeny, IA, USA, pp 63-89
- Wang L, Lyons J, Kanehl P (2002) Effects of watershed best management practices on habitat and fish in Wisconsin streams. *Journal of the American Water Resources Association* 38:663-680
- Wang L, Lyons J, Kanehl P, Bannerman R, Emmons E (2000) Watershed urbanization and changes in fish communities in southeastern Wisconsin streams. *Journal of the American Water Resources Association* 36:1173-1189
- Wang L, Lyons J, Kanehl P, Bannerman R (2001) Impacts of urbanization on stream habitat and fish across multiple spatial scales. *Environmental Management* 28:255-266

- Wang L, Lyons J, Kanehl P, Gatti R (1997) Influences of Watershed Land Use on Habitat Quality and Biotic Integrity in Wisconsin Streams. *Fisheries* 22:6-12
- Ward JV, Stanford JA (1983) The serial discontinuity concept of lotic ecosystems. In: Fontaine TD, Bartell SM (eds), *Dynamics of Lotic Ecosystems*. Ann Arbor Science, Ann Arbor, pp 29-42
- Waters TF (1995) Sediment in streams: sources, biological effects, and control. *American Fisheries Society Monograph* 7, Bethesda, Maryland, 251 pp
- Weaver LA, Garman GC (1994) Urbanization of a Watershed and Historical Changes in a Stream Fish Assemblage. *Transactions of the American Fisheries Society* 123:162-172
- Westra JV, Zimmerman JKH, Vondracek B (2004) Do Conservation Practices and Programs Benefit the Intended Resource Concern? *Agricultural and Resource Economics Review* 33:105-120
- Wolman MG, Schick AP (1967) Effects of construction on fluvial sediment, urban and suburban areas of Maryland. *Water Resour.Res.* 3:451-464
- Wood PJ, Armitage PD (1997) Biological effects of fine sediment in the lotic environment. *Environmental Management* 21:203-217
- Young KD, Thackston EL (1999) Housing Density and Bacterial Loading in Urban Streams. *Journal of Environmental Engineering* 125:1177-1180
- Zaimes GN, Schultz RC, Isenhardt TM (2004) Stream bank erosion adjacent to riparian forest buffers, row-crop fields, and continuously-grazed pastures along Bear Creek in central Iowa. *Journal of Soil and Water Conservation* 59:19-27

Zimmerman JKH, Vondracek B, Westra J (2003) Agricultural Land Use Effects on
Sediment Loading and Fish Assemblages in Two Minnesota (USA) Watersheds.
Environmental Management 32:93-105

Table 3.1. Variable loadings from categorical principal component analysis of all streams <500 link magnitude in Hot Continental Division of the Missouri River basin. The measurement scale for all variables was percent of a variable in a stream segment's watershed. Variables were discretized into 10 ordinal categories. Loadings in bold were considered representative of the corresponding principal component.

	Principal Component			
	1	2	3	4
Eigenvalue	2.68	2.01	1.70	1.13
% variance explained	26.77	20.13	16.99	11.29
Cumulative % variance	26.77	46.90	63.90	75.18
Floodplain and alluvium gravel terraces	-0.216	-0.528	0.354	0.542
Deeply weathered loess	0.722	-0.205	-0.281	-0.278
Red clay, massive clay that is generally kaolinitic	-0.482	0.693	0.047	-0.180
Soil rock fragment class 1 - 0% in watershed	0.807	-0.221	-0.232	-0.014
Soil rock fragment class 2 - 0.1-10% in watershed	-0.019	0.180	0.881	-0.185
Soil rock fragment class 3 - 10.1-20% in watershed	-.558	0.184	-0.692	0.073
Fine soil texture in watershed	-0.044	-0.303	0.009	0.598
Depth to bedrock class 5 (92-122cm)	0.183	-0.541	0.342	-0.424
Soil hydrologic group B (moderately low runoff potential)	-0.616	-0.625	-0.241	-0.263
Soil hydrologic group C (moderately high runoff potential)	0.679	0.567	0.092	0.279

Table 3.2. Variable loadings from categorical principal component analysis of all streams in Prairie Division of the Missouri River basin. The measurement scale for all variables was percent of a variable in a stream segment's watershed. Variables were discretized into 10 ordinal categories. Loadings in bold were considered representative of the corresponding principal component.

	Principal Component			
	1	2	3	4
Eigenvalue	2.88	2.02	1.52	1.15
% variance explained	28.84	20.24	15.16	11.48
Cumulative % variance	28.84	49.08	64.24	75.71
Pre-Wisconsinan drift	-0.179	-0.234	-0.563	0.623
Wisconsinan loess	0.179	0.441	0.644	-0.232
Soil hydrologic group B (moderately low runoff potential)	0.825	0.142	-0.058	-0.041
Soil hydrologic group C (moderately high runoff potential)	-0.565	-0.089	0.540	0.411
Soil hydrologic group D (high runoff potential)	-0.454	-0.116	-0.546	-0.438
Medium fine soil texture in watershed	-0.154	0.934	-0.210	0.160
Medium soil texture in watershed	0.143	-0.926	0.255	-0.106
Depth to bedrock class 5 (92-122cm)	0.172	-0.002	0.226	0.537
Soil rock fragment class 1 - 0% in watershed	-0.873	0.041	0.124	-0.085
Soil rock fragment class 5 - 40.1-60% in watershed	0.882	-0.032	-0.125	0.106

Table 3.3. NRCS conservation practices applied between 1999 and 2009 in the Missouri River basin that were included for assessment of conservation practice effectiveness. Practices group codes are soil disturbance (SD) and sediment entering stream channel (SEC). SD practices are designed to reduce or prevent soil erosion and SEC practices prevent eroded sediment from entering stream channels. There are two groups of SEC practices, and they differ by their measurement unit, SEC-ha are applied by area and SEC-m are applied linearly. The NRCS practice names, codes, and definitions are from the national NRCS practice standards.

Practice Name	NRCS Practice Code	# Applied	Amount Applied (ha)	Applied Amount (ac)	NRCS Practice Definition	Notes
SD Practices						
Conservation Cover	327	61,466	877,099	2,167,336	Establishing and maintaining permanent vegetative cover to protect soil and water resources.	
Residue and Tillage Management, No-Till/Strip Till/Direct Seed	329	24,385	575,830	1,422,892	Managing the amount, orientation and distribution of crop and other plant residue on the soil surface year round while limiting soil-disturbing activities to only those necessary to place nutrients; condition residue and plant crops.	
Residue Management, No-Till/Strip Till	329A	34,652	749,623	1,852,319	Same as 329	
Residue Management, Mulch Till	329B	29,577	662,868	1,637,948	Same as 329	
Residue Management,	329C	774	24,278	59,991	Same as 329	

Ridge Till						
Critical Area Planting	342	8,441	14,169	35,013	Establishing permanent vegetation on sites that have or are expected to have high erosion rates; and on sites that have physical; chemical or biological conditions that prevent the establishment of vegetation with normal practices.	
Residue and Tillage Management, Mulch Till	345	11,965	258,678	639,196	Managing the amount, orientation, and distribution of crop and other plant residues on the soil surface year-round, while growing crops on pre-formed ridges alternated with furrows protected by crop residue.	Reduction as opposed to moldboard plow. Soil disturbance still occurs, presumably at a lower rate. .
Use Exclusion	472	106,297	963,311	2,380,343	The temporary or permanent exclusion of animals; people or vehicles from an area.	
Prescribed Grazing	528	35,596	3,302,217	8,159,777	Managing the controlled harvest of vegetation with grazing animals.	Assuming stocking rate reductions and that grazing was present before implementation.

Prescribed Grazing	528A	23,485	2,069,044	5,112,607	Mange the harvest of vegetation with grazing and/or browsing animals	Assuming stocking rate reductions and that grazing was present before implementation.
Restoration and Management of Rare and Declining Habitats	643	8,815	111,991	276,730	Restoring and managing rare and declining habitats and their associated wildlife species to conserve biodiversity.	May involve wetlands. Somewhat insufficient information to determine to which lands this applies. National standard appears to be terrestrial oriented. Haying may occur but no tillage operations.
Upland Wildlife Habitat Management	645	107,341	2,195,349	5,424,707	Provide and manage upland habitats and connectivity within the landscape for wildlife.	Can apply to forests, cropland, and pasture/rangeland.

SEC-ha Practices

Conservation Crop Rotation	328	118,947	2,695,720	6,661,124	Growing crops in a recurring sequence on the same field.
Contour Farming	330	34,578	631,633	1,560,766	Tillage, planting, and other farming operations performed on or near the contour of the field slope.

Contour Buffer Strips	332	2,030	18,207	44,989	Narrow strips of permanent, herbaceous vegetative cover established across the slope and alternated down the slope with parallel; wider cropped strips.	
Cover Crop	340	12,031	196,425	485,366	Grasses; legumes; forbs; or other herbaceous plants established for seasonal cover and other conservation purposes.	
Residue Management, Seasonal	344	19,837	447,943	1,106,867	Managing the amount, orientation, and distribution of crop and other plant residues on the soil surface during a specified period of the year, while planting annual crops on a clean-tilled seedbed, or when growing biennial or perennial seed crops.	
Residue and Tillage Management, Ridge Till	346	99	2,403	5,939	Managing the amount, orientation, and distribution of crop and other plant residues on the soil surface year-round, while growing crops on pre-formed ridges alternated with furrows protected by crop residue.	Clean tillage is utilized; therefore, soil disturbance is not reduced.

Riparian Herbaceous Cover	390	635	3,847	9,505	Grasses; grass-like plants and forbs that are tolerant of intermittent flooding or saturated soils and that are established or managed in the transitional zone between terrestrial and aquatic habitats.
Riparian Forest Buffer	391	4,007	9,171	22,662	An area of predominantly trees and/or shrubs located adjacent to and up-gradient from watercourses or water bodies.
Filter Strip	393	20,121	29,918	73,928	A strip or area of herbaceous vegetation situated between cropland, grazing land, or disturbed land (including forestland) and environmentally sensitive areas.
Grassed Waterway	412	15,488	65,586	162,064	A natural or constructed channel that is shaped or graded to required dimensions and established with suitable vegetation.
Mulching	484	5,431	50,123	123,854	Applying plant residues; by-products or other suitable materials produced off site, to the land surface.

Wetland Restoration	657	4,821	34,656	85,636	The rehabilitation of a degraded wetland or the reestablishment of a wetland so that soils; hydrology, vegetative community, and habitat are a close approximation of the original natural condition that existed prior to modification to the extent practicable.
Wetland Creation	658	175	548	1,354	The creation of a wetland on a site that was historically non-wetland.
Wetland Enhancement	659	569	4,195	10,366	The rehabilitation or re-establishment of a degraded wetland, and/or the modification of an existing wetland.

SEC-m Practices

Field Border	386	9,724	62,478,491 (m)	19,043,444 (ft)	A strip of permanent vegetation established at the edge or around the perimeter of a field.
Terrace	600	26,054	332,844,43 2 (m)	101,450,98 3 (ft)	An earth embankment or a combination ridge and channel constructed across the field slope.

Table 3.4. Classification table for lithophil guild presence/absence model in the Prairie Division of the Missouri River basin. Model was developed using classification trees. Split-sample validation was used to assess model accuracy. Approximately 75% of the data were used in the training dataset to parameterize the model, and the remaining data were used as the test dataset.

Dataset	Observed	Predicted		Percent Correct
		Absent	Present	
Training	Absent	94	70	57.3%
	Present	25	387	93.9%
	Overall Percentage	20.7%	79.3%	83.5%
Test	Absent	24	19	55.8%
	Present	18	115	86.5%
	Overall Percentage	23.9%	76.1%	79.0%

Table 3.5 Candidate multiple-regression models used to predict lithophil guild abundance in Hot Continental Division of the Missouri River basin. Akaike's Information Criterion (AIC) values, change in AIC values (ΔAIC), and model weights (ω_i) were used to select candidate models for further evaluation. These models excluded outliers (guild abundance = 0 or > 0.55). Practices group codes are soil disturbance (SD) and sediment entering stream channel (SEC). SD practices are designed to reduce or prevent soil erosion and SEC practices prevent eroded sediment from entering stream channels. Squared variables represent quadratic effects.

Natural Model	AIC	ΔAIC	ω_i
Null (intercept only)	-268.627	0.21	0.473
Principal Components 1-4	-268.842	0.00	0.527
Threat Models	AIC	ΔAIC	ω_i
Null (intercept only)	-268.627	9.57	0.004
Natural Model; WArea*; Ag Index ² ; Urban Index ² ; Ag Index \times Urban Index	-269.266	8.93	0.006
Natural Model; WArea; Ag Index	-270.906	7.29	0.013
Natural Model; WArea; Ag Index ² ; NonAg Index ² ; Ag Index \times NonAg Index	-274.151	4.05	0.068
Natural Model; WArea; Ag Index ² ; Urban Index ² ; PntSrc Index; Index; Ag Index \times Urban Index	-274.704	3.50	0.090
Natural Model; WArea; Ag Index ² ; Urban Index ² ; Infrastructure Index ² ; PntSrc Index ² ; Ag Index \times Urban Index	-277.115	1.08	0.301
Natural Model; WArea; Ag Index ² ; Urban Index ² ; Infrastructure Index ² ; Ag Index \times Urban Index	-278.199	0.00	0.517
Conservation Practice Model	AIC	ΔAIC	ω_i
Natural Model; WArea; Ag Index ² ; Urban Index ² ; Infrastructure Index; PntSrc Index; Ag Index \times Urban Index; SEC-ha ² ; SD ²	-287.965	4.66	0.0566
Natural Model; WArea; Ag Index ² ; Urban Index ² ; Infrastructure Index ² ; PntSrc Index ² ; Ag Index \times Urban Index; SEC-ha ² ; SD ²	-291.678	0.94	0.3624
Natural Model; WArea; Ag Index ² ; Urban Index ² ; Index ² ; Ag Index \times Urban Index; SEC-ha ^{2a} ; SD ^{2b}	-292.622	0.00	0.5810

*Total watershed area

^aConservation practices implemented as unit area that were designed to reduce sediment from entering stream channels

^bConservation practices that were designed to reduce soil disturbance

Table 3.6. Final model and model-averaged parameter estimates used to predict guild abundance of lithophilous spawners in the Hot Continental Division of the Missouri River basin. Prefix Log10 indicates variable was transformed using \log_{10} , ARC indicates Arcsine transformation, and SQRT indicates square root transformation.

Parameter	Beta
Intercept	0.3957
Principal component one	0.0146
Principal component two	0.0247
Principal component three	-0.0266
Principal component four	-0.0492
Log10 Watershed Area km ²	0.0099
ARC Agr Index	0.4048
ARC Agr Index ²	-0.3673
ARC Urban Index	-0.2771
ARC Urban Index ²	0.1424
ARC Agr Index \times ARC Urban Index	0.1123
ARC Infrastructure Index	-0.0198
ARC Infrastructure Index ²	-0.0917
Point-source Index	-0.0003
Point-source Index ²	0.0000
ARC SEC-ha ^a	-0.0709
ARC SEC-ha ²	0.6110
SQRT SD ^b	-0.1011
SQRT SD ²	0.0216

^aConservation practices implemented as unit area that were designed to reduce sediment from entering stream channels

^bConservation practices that were designed to reduce soil disturbance

Table 3.7. Candidate multiple-regression models used to predict omnivore guild abundance in Hot Continental Division of the Missouri River basin. Akaike's Information Criterion (AIC) values, change in AIC values (ΔAIC), and model weights (ω_i) were used to select candidate models for further evaluation. Practices group codes are soil disturbance (SD) and sediment entering stream channel (SEC). SD practices are designed to reduce or prevent soil erosion and SEC practices prevent eroded sediment from entering stream channels. Squared variables represent quadratic effects.

Natural Model	AIC	ΔAIC	ω_i
Null (intercept only)	-187.607	15.75	0.000
Principal Components 1-4	-203.354	0.00	1.000
Threat Models	AIC	ΔAIC	ω_i
Null	-187.607	40.35	0.000
Natural Model; WArea*; Ag Index	-207.748	20.21	0.000
Natural Model; WArea; Ag Index ² ; Nonag Index ² ; Ag Index \times Nonag Index	-222.052	5.90	0.028
Natural Model; WArea; Ag Index ² ; Urban Index ² ; Ag Index \times Urban Index	-225.499	2.46	0.158
Natural Model; WArea; Ag Index ² ; Urban Index ² ; Infrastructure Index ² ; PntSrc Index ² ; Ag Index \times Urban Index	-226.600	1.36	0.274
Natural Model, Area, Ag Index ² , Urban Index ² , Index ² , Ag Index*Urban Index	-227.955	0.00	0.540
Conservation Models	AIC	ΔAIC	ω_i
Null	-187.607	37.22	0.000
Natural Model; WArea; Ag Index ² ; Urban Index ² ; Ag Index \times Urban Index; SEC-ha ² ; SD ²	-219.857	4.97	0.056
Natural Model; WArea; Ag Index ² ; Urban Index ² ; Index ² ; Ag Index \times Urban Index; SEC-ha ² ; SD ²	-223.078	1.75	0.278
Natural Model; WArea; Ag Index ² ; Urban Index ² ; Infrastructure Index ² ; PntSrc Index ² ; Ag Index \times Urban Index; SEC-ha ^{2a} ; SD ^{2b}	-224.828	0.00	0.667

*Total watershed area

^aConservation practices implemented as unit area that were designed to reduce sediment from entering stream channels

^bConservation practices that were designed to reduce soil disturbance

Table 3.8. Final model and model-averaged parameter estimates used to predict guild abundance of omnivores in the Hot Continental Division of the Missouri River basin. Prefix Log10 indicates variable was transformed using \log_{10} , ARC indicates Arcsine transformation, and SQRT indicates square root transformation.

Parameter	Beta
Intercept	0.5587
Principal component one	0.0013
Principal component two	-0.0143
Principal component three	-0.0089
Principal component four	-0.0110
Log10 Watershed Area km ²	-0.0253
ARC Agr Index	0.6631
ARC Agr Index ²	-0.4114
ARC Urban Index	-0.4716
ARC Urban Index ²	0.3526
ARC Agr Index × ARC Urban Index	0.0369
ARC Infrastructure Index	-0.2220
ARC Infrastructure Index ²	0.3345
Point-source Index	-0.0043
Point-source Index ²	0.0000
ARC SEC-ha ^a	0.6396
ARC SEC-ha ²	-0.9984
SQRT SD ^b	-0.0127
SQRT SD ²	0.0029

^aConservation practices implemented as unit area that were designed to reduce sediment from entering stream channels

^bConservation practices that were designed to reduce soil disturbance

Table 3.9. Candidate multiple-regression models used to predict lithophilous spawner guild abundance in Prairie Division of the Missouri River basin. Akaike's Information Criterion (AIC) values, change in AIC values (ΔAIC), and model weights (ω_i) were used to select candidate models for further evaluation. Practices group codes are soil disturbance (SD) and sediment entering stream channel (SEC). SD practices are designed to reduce or prevent soil erosion and SEC practices prevent eroded sediment from entering stream channels. There are two groups of SEC practices, and they differ by their measurement unit, SEC-ha are applied by area and SEC-m are applied linearly. Squared variables represent quadratic effects.

Natural Model	AIC	ΔAIC	ω_i
Null	-363.447	2.81	0.197
Principal Components 1-4	-366.254	0.00	0.803
Threat Models	AIC	ΔAIC	ω_i
Null	-363.447	86.48	0.000
Natural Model; WArea*; Ag Index	-433.431	16.49	0.000
Natural Model; WArea; Ag Index ² ; Urban Index ² ; PntSrc Index; Index; Ag Index×Urban Index	-441.596	8.33	0.010
Natural Model; WArea; Ag Index ² ; Urban Index ² ; Ag Index × Urban Index	-443.870	6.06	0.031
Natural Model; WArea; Ag Index ² ; Nonag Index ² ; Ag Index × Nonag Index	-444.301	5.62	0.038
Natural Model; WArea; Ag Index ²	-444.432	5.49	0.041
Natural Model; WArea; Ag Index ² ; Urban Index ² ; Infrastructure Index ² ; Ag Index×Urban Index	-445.519	4.41	0.071
Natural Model; WArea; Ag Index ² ; Urban Index ² ; PntSrc Index ² ; Ag Index × Urban Index	-447.277	2.65	0.170
Natural Model; WArea; Ag Index ² ; Urban Index ² ; Infrastructure Index ² ; PntSrc Index ² ; Ag Index × Urban Index	-449.925	0.00	0.639
Conservation Models	AIC	ΔAIC	ω_i
Null	-363.447	93.33	0.0000
Natural Model; WArea; Ag Index ² ; Urban Index ² ; PntSrc Index ² ; Ag Index×Urban Index;	-455.257	1.51	0.3192

SEC-ha; SD; SEC-m

Natural Model; WArea; Ag Index²; Urban
Index²; Infrastructure Index²; PntSrc Index²; Ag -456.772 0.00 0.6808
Index × Urban Index; SEC-ha^a; SEC-m^b; SD^c

*Total watershed area

^aConservation practices implemented as unit area that were designed to reduce sediment from entering stream channels

^bConservation practices implemented as unit length that were designed to reduce sediment from entering stream channels

^cConservation practices that were designed to reduce soil disturbance

Table 3.10. Final model and model-averaged parameter estimates used to predict guild abundance of lithophilous spawners in the Hot Continental Division of the Missouri River basin. Prefix Log10 indicates variable was transformed using \log_{10} , and ARC indicates Arcsine transformation, and SQRT indicates square root transformation.

Parameter	Beta
Intercept	-1.7404
Principal component one	-0.0192
Principal component two	0.0128
Principal component three	-0.0109
Principal component four	0.0088
Log10 Watershed Area km ²	-0.1071
Agr Index	-0.0069
Agr Index ²	0.0001
Log10 Urban Index	0.4291
Log10 Urban Index ²	-0.1247
Agr Index \times Log10 Urban Index	-0.0003
ARC Infrastructure Index	0.1696
ARC Infrastructure Index ²	-0.2009
Log10 Point-source Index	3.2144
Log10 Point-source Index ²	-1.1534
ARC SEC-ha ^a	0.0504
SQRT SEC-m ^b	-0.0032
ARC SD ^c	0.0146

^aConservation practices implemented as unit area that were designed to reduce sediment from entering stream channels

^bConservation practices implemented as unit length that were designed to reduce sediment from entering stream channels

^cConservation practices that were designed to reduce soil disturbance

Table 3.11. Criteria used to classify stream segments in Missouri River basin into conservation practice effectiveness groups. BCA = base condition abundance and assumes no conservation practices were implemented. RCA = reference condition abundance and was used to classify streams as ‘more’ or ‘less’ disturbed. Reference condition abundance was calculated as mean guild abundance from fish samples in ‘less’ disturbed stream segments. CCA = conservation condition abundance and accounts for the effects of currently implemented conservation practices.

Conservation Practice Effectiveness Group	Criteria	Criteria Values Used by Division		
		Hot Continental		Prairie
		Lithophils	Omnivores	Lithophils
Agriculture conservation not needed	BCA>RCA	BCA>0.38	BCA<0.48	BCA>0.24
Non-agriculture conservation needed	BCA<RCA>CCA & agr index score <50 th percentile	BCA<0.38>CCA & agr index score <30	BCA>0.48<CCA & agr index score <30	BCA<0.24>CCA & agr index score <45
Agriculture conservation practices not effective	BCA<RCA>CCA & agr index score >50 th percentile	BCA<0.38>CCA & agr index score >30	BCA>0.48<CCA & agr index score >30	BCA<0.24>CCA & agr index score >45
Agriculture conservation practices effective	BCA<RCA<CCA	BCA<0.38<CCA	BCA>0.48>CCA	BCA<0.24<CCA

Table 3.12. Mean values for each conservation practice effectiveness group of predicted lithophil guild abundance scenarios and NRCS conservation practices in Hot Continental Division of the Missouri River basin. Mean values within rows that have different subscripts are significantly different at $\alpha = 0.05$ using T-tests and Bonferroni corrections. Standard error is in parentheses.

	Likely that			
	agr cons not needed (n=4,151)	non-agr cons needed (n=3996)	agr cons not effective (n=2269)	agr cons effective (n=113)
Percent of total streams	68.93	19.47	11.05	0.55
Base condition lithophil abundance	0.4311 _a (0.0003)	0.3048 _b (0.0009)	0.2977 _c (0.0021)	0.3420 _d (0.0031)
Conservation condition lithophil abundance	0.3995 _a (0.0007)	0.2967 _b (0.0010)	0.2613 _c (0.0020)	0.5618 _d (0.0171)
Percent difference from base to conservation abundance	-7.4409 _a (0.1514)	-2.5805 _b (0.1345)	-12.6472 _c (0.3987)	66.9601 _d (5.5495)
Watershed percent SEC-ha ^a practices	0.8752 _a (0.0489)	0.0130 _b (0.0032)	1.8571 _c (0.0934)	13.8535 _d (1.7869)
Watershed percent SD ^b practices	2.9412 _a (0.0664)	0.3826 _b (0.0298)	2.5944 _a (0.0935)	31.3680 _c (2.3294)

^aConservation practices implemented as unit area that were designed to reduce sediment from entering stream channels

^bConservation practices that were designed to reduce soil disturbance

Table 3.13. Mean values for each conservation practice effectiveness group of predicted omnivore guild abundance scenarios and NRCS conservation practices in Hot Continental Division of the Missouri River basin. Mean values within rows that have different subscripts are significantly different at $\alpha = 0.05$ using T-tests and Bonferroni corrections. Standard error is in parentheses.

	Likely that			
	agr cons not needed (n=3790)	non-agr cons needed (n=6949)	agr cons not effective (n=9502)	agr cons effective (n=288)
Percent of total streams	18.46	33.85	46.29	1.40
Base condition omnivore abundance	0.4360 _a (0.0006)	0.5554 _b (0.0007)	0.5832 _c (0.0006)	0.5091 _d (0.0031)
Conservation condition omnivore abundance	0.4367 _a (0.0006)	0.5559 _b (0.0008)	0.5956 _c (0.0007)	0.4167 _d (0.0087)
Percent difference from base to conservation	0.1556 _a (0.0458)	0.0904 _a (0.0264)	2.6649 _b (0.0562)	-25.7038 _c (3.7064)
Watershed percent SEC-ha ^a practices	0.1306 _a (0.0173)	0.0575 _a (0.0108)	1.3746 _b (0.0482)	14.7932 _c (1.9203)
Watershed percent SD ^b practices	1.0468 _a (0.0548)	1.7354 _b (0.0831)	3.6786 _c (0.0879)	5.5573 _d (0.5311)

^aConservation practices implemented as unit area that were designed to reduce sediment from entering stream channels

^bConservation practices that were designed to reduce soil disturbance

Table 3.14. Mean values for each conservation practice effectiveness group of predicted lithophil guild abundance scenarios and NRCS conservation practices in Prairie Division of the Missouri River basin. Mean values within rows that have different subscripts are significantly different at $\alpha = 0.05$ using T-tests and Bonferroni corrections. Standard error is in parentheses.

	Likely that			
	agr cons likely not needed (n=62,903)	non-agr cons needed (n=5982)	agr cons not effective (n=15,051)	agr cons effective (n=1423)
Percent of total streams	73.69	7.01	17.63	1.67
Base condition lithophil abundance	0.3235 _a (0.0002)	0.1964 _b (0.0004)	0.1849 _c (0.0003)	0.2322 _d (0.0002)
Conservation condition lithophil abundance	0.3209 _a (0.0002)	0.1897 _b (0.0005)	0.1786 _c (0.0003)	0.2493 _d (0.0002)
Percent difference from base to conservation	-0.8708 _a (0.0334)	-3.3070 _b (0.0972)	-3.4068 _b (0.0670)	7.44 _c (0.1353)
Watershed percent SEC-ha ^a practices	9.0070 _a (0.0762)	8.3658 _b (0.1717)	10.9972 _c (0.1032)	13.7003 _d (0.4660)
Watershed percent SEC-m ^b practices	139.3406 _a (1.9898)	118.9317 _b (3.4714)	139.5959 _c (1.7880)	6.4598 _d (0.9009)
Watershed percent SD ^c practices	10.9665 _a (0.0749)	10.0037 _b (0.1418)	12.2990 _a (0.0861)	17.6259 _c (0.4625)

^aConservation practices implemented as unit area that were designed to reduce sediment from entering stream channels

^bConservation practices implemented as unit length that were designed to reduce sediment from entering stream channels

^cConservation practices that were designed to reduce soil disturbance

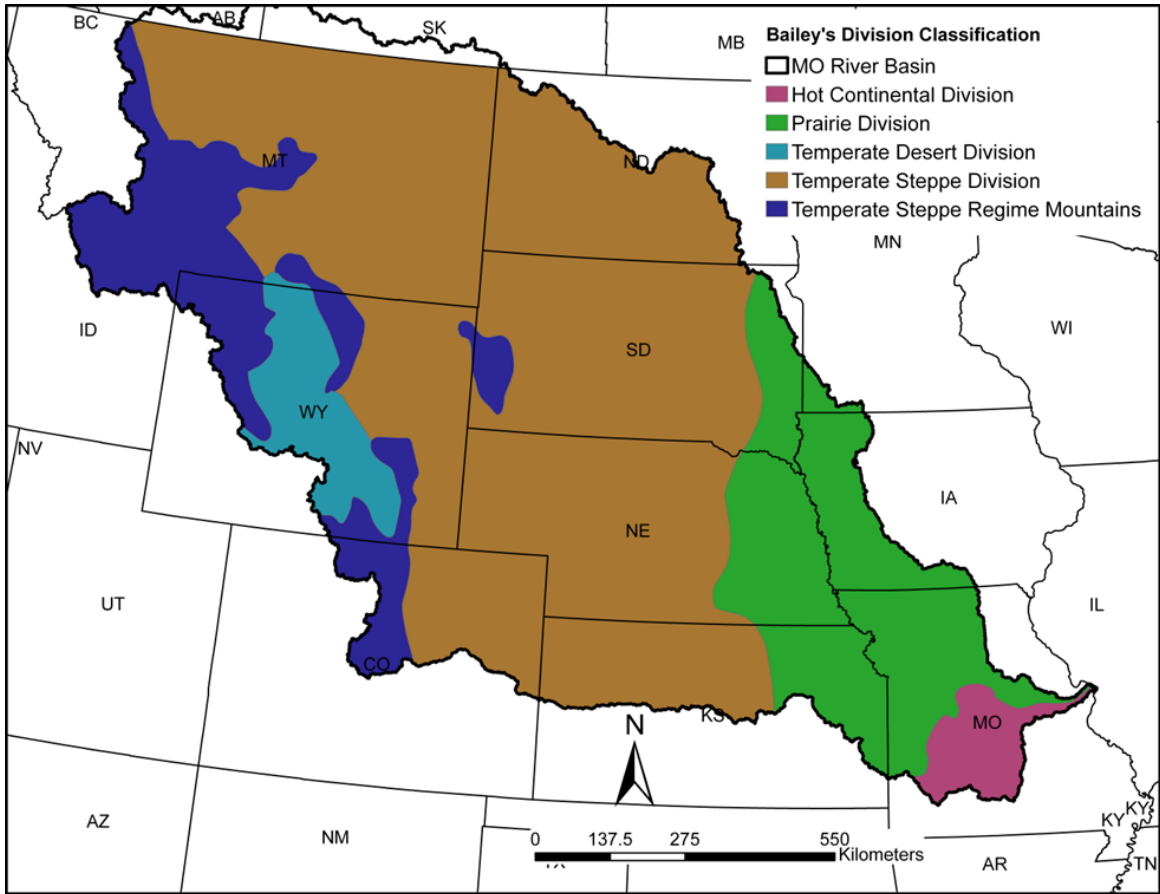

Figure 3.1. Map of Missouri River basin and Bailey's Division that were used as an ecoregion classification.

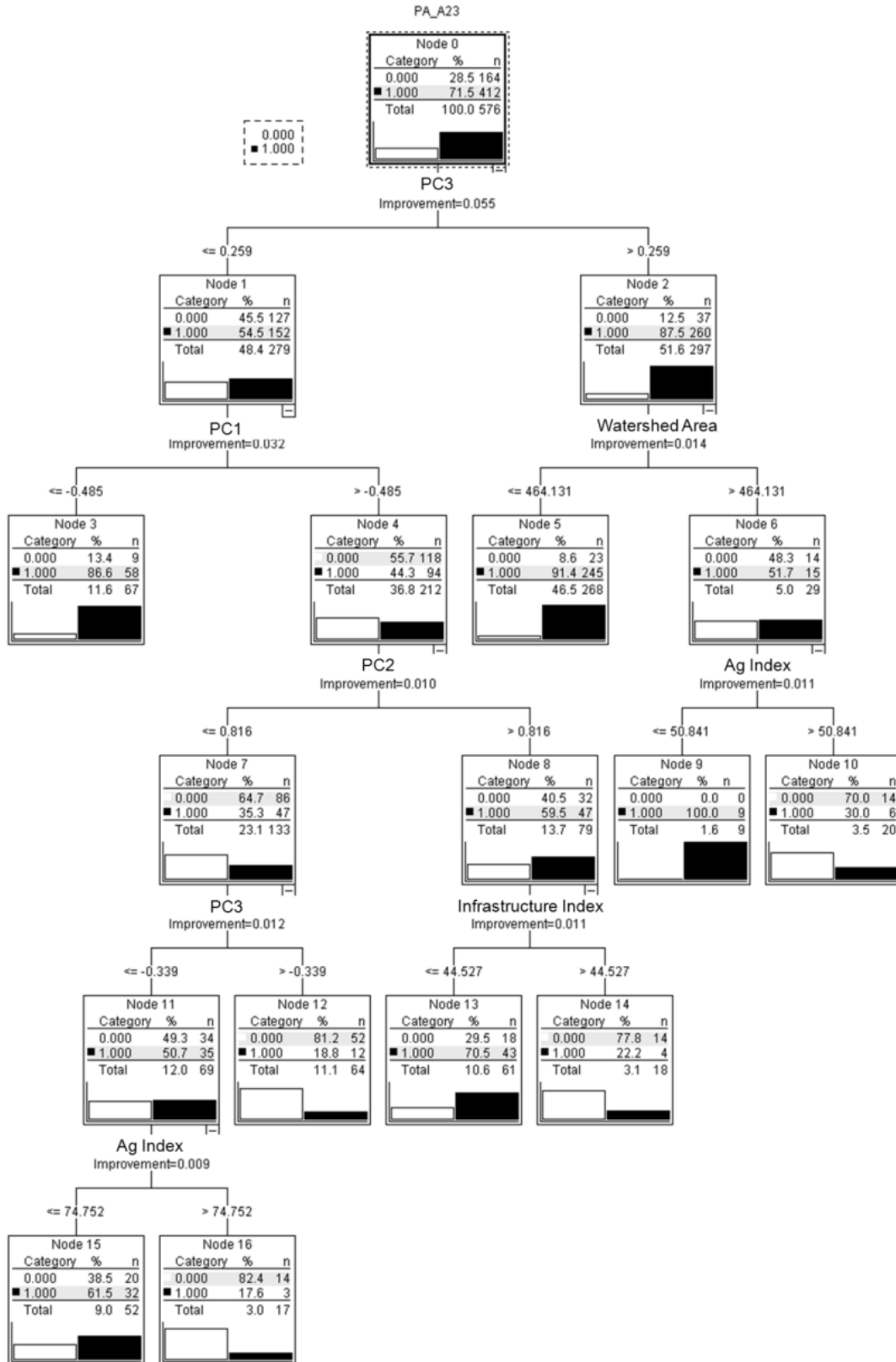

Figure 3.2. Classification tree model that was developed to predict lithophil presence and absence (PA_A23) in the Prairie Division of the Missouri River basin. Physiographic

features were summarized using categorical principal components analysis and the resulting principal components (PC 1-4) were used as model inputs (see Table 3.2). Total watershed area (km²) and five threat indices representing agricultural, urbanization, point-source pollution, infrastructure, and non-agricultural threats (Fore Chap. 2) were also used as model inputs. The bars represent the number of samples classified in its respective node. White bars and text values of zero represent absences and black bars and text values of one represent presence. The top node begins with all the data from the sample and each branch of the tree contains the variable and its values that were used to classify guild presence/absence. Terminal nodes (those with no branches) represent final classifications of presence/absence.

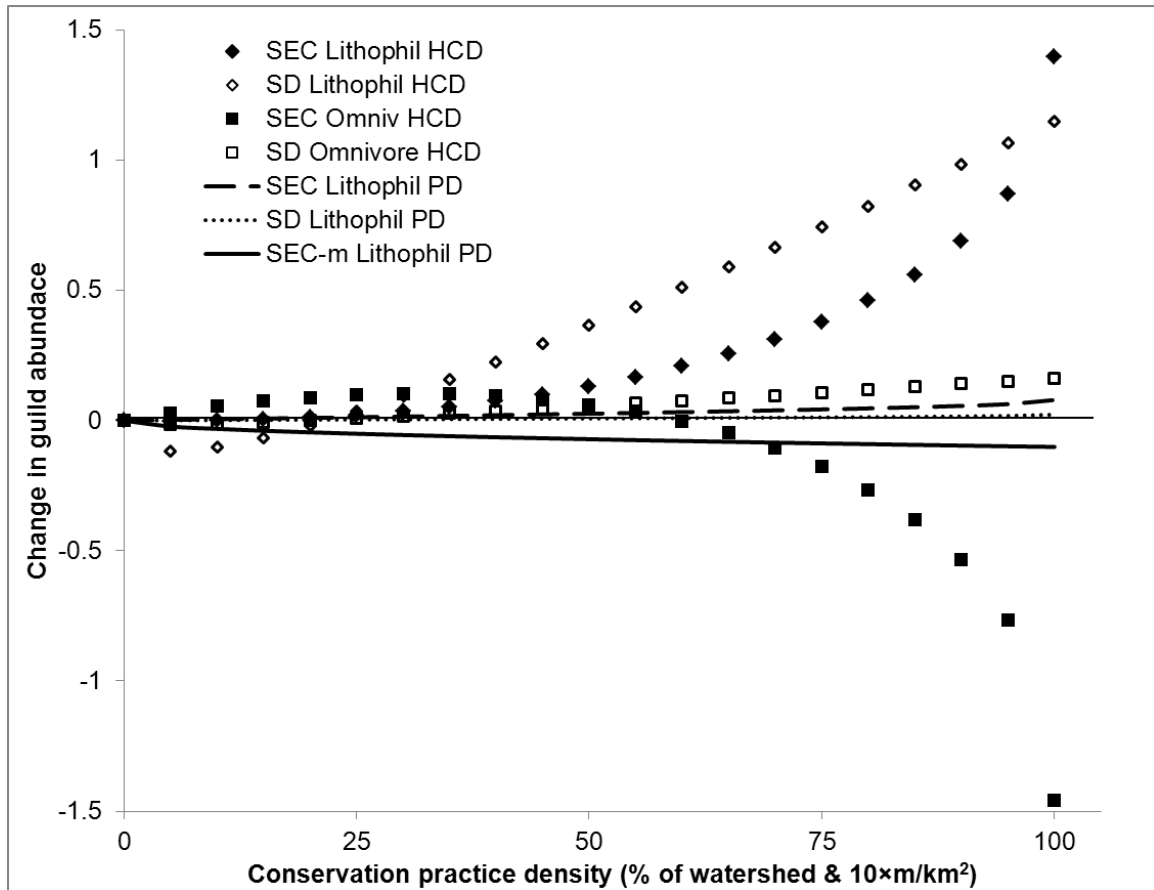

Figure 3.3. Expected change in guild abundance per unit increase of conservation practices. SEC = conservation practices designed to reduce sediment entering stream channels that were applied in hectares. SEC-m = conservation practices designed to reduce sediment entering stream channels that were applied in meters. SD = conservation practices designed to reduce soil disturbance and applied in hectares. Plots were developed by using each conservation practice's parameter estimates from its respective assessment model (Tables 3.6, 3.8, and 3.10) and excluded the effects of all other parameters. All effects in Hot Continental Division (HCD) are quadratics and those in Prairie Division (PD) are linear. The scale for SEC-m practices is 10 times the value shown and the units are m/km^2 .

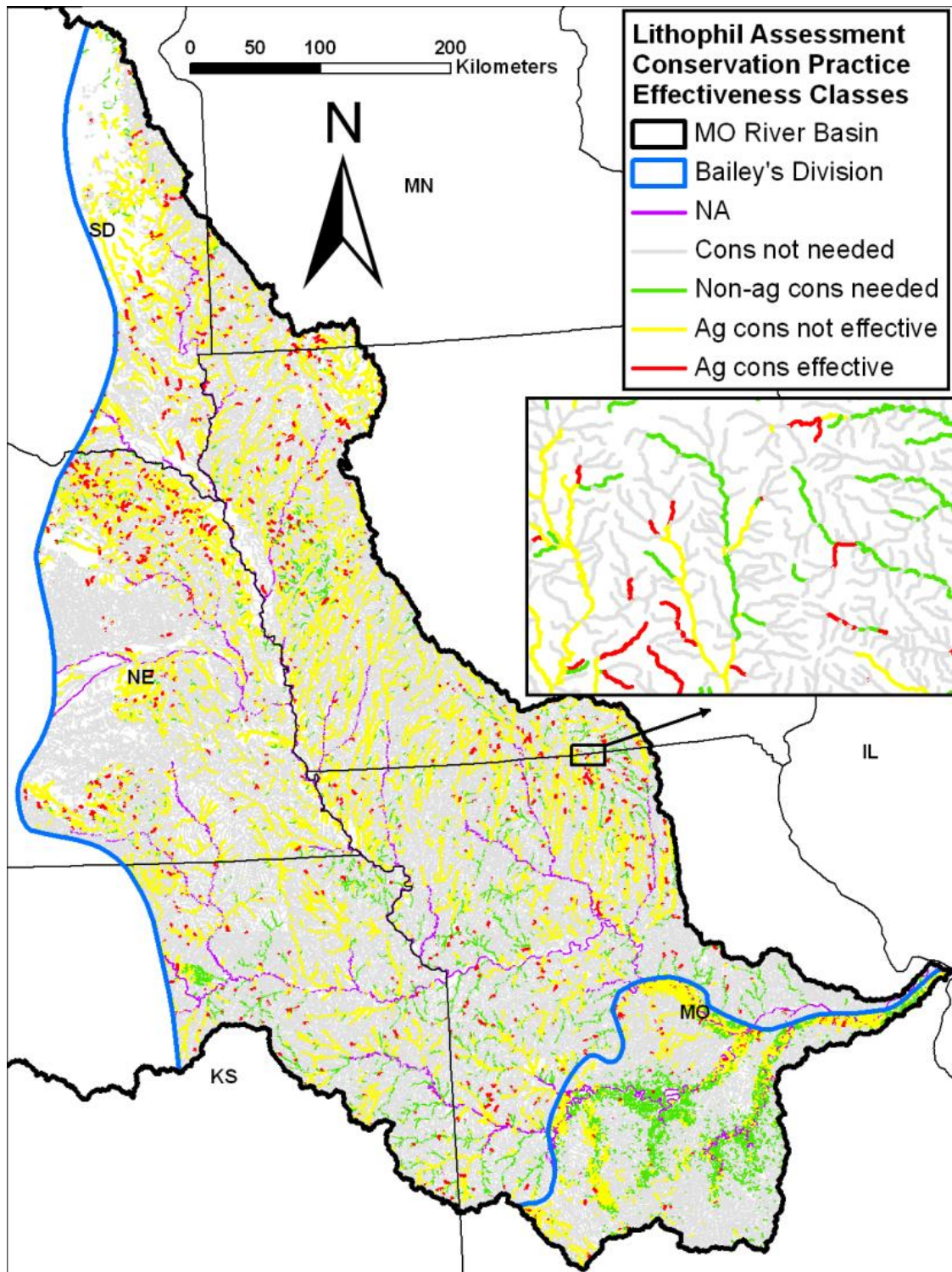

Figure 3.4. Map of stream segments <500 link magnitude classified into predicted conservation practice effectiveness groups in the Prairie and Hot Continental Divisions of the Missouri River basin. Lithophilous spawners were used as an indicator. Refer to Table 3.11 for criteria used to delineate conservation practice effectiveness groups. NA refers to streams too large for assessment (link magnitude >500).

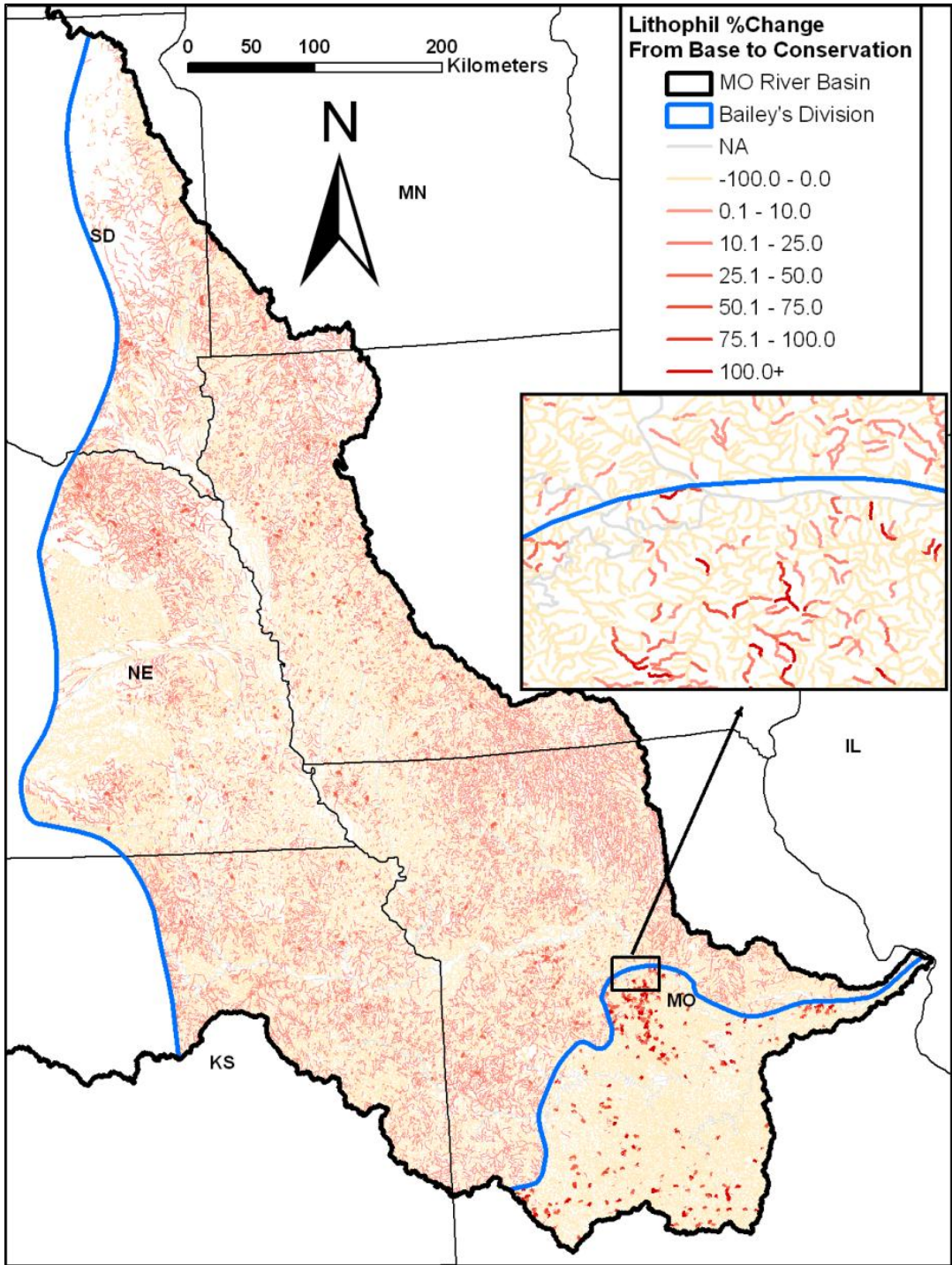

Figure 3.5. Predicted percent change in lithophil guild abundance from base condition abundance to conservation condition abundance for stream segments with link magnitude <500 in the Prairie and Hot Continental Division of the Missouri River basin. Base condition abundance was predicted assuming no conservation practices were applied on the landscape and conservation condition abundance accounted for the effects of currently applied NRCS soil conservation practices. Positive values indicate positive conservation practice effects because lithophil abundance was expected to increase with conservation practice density.

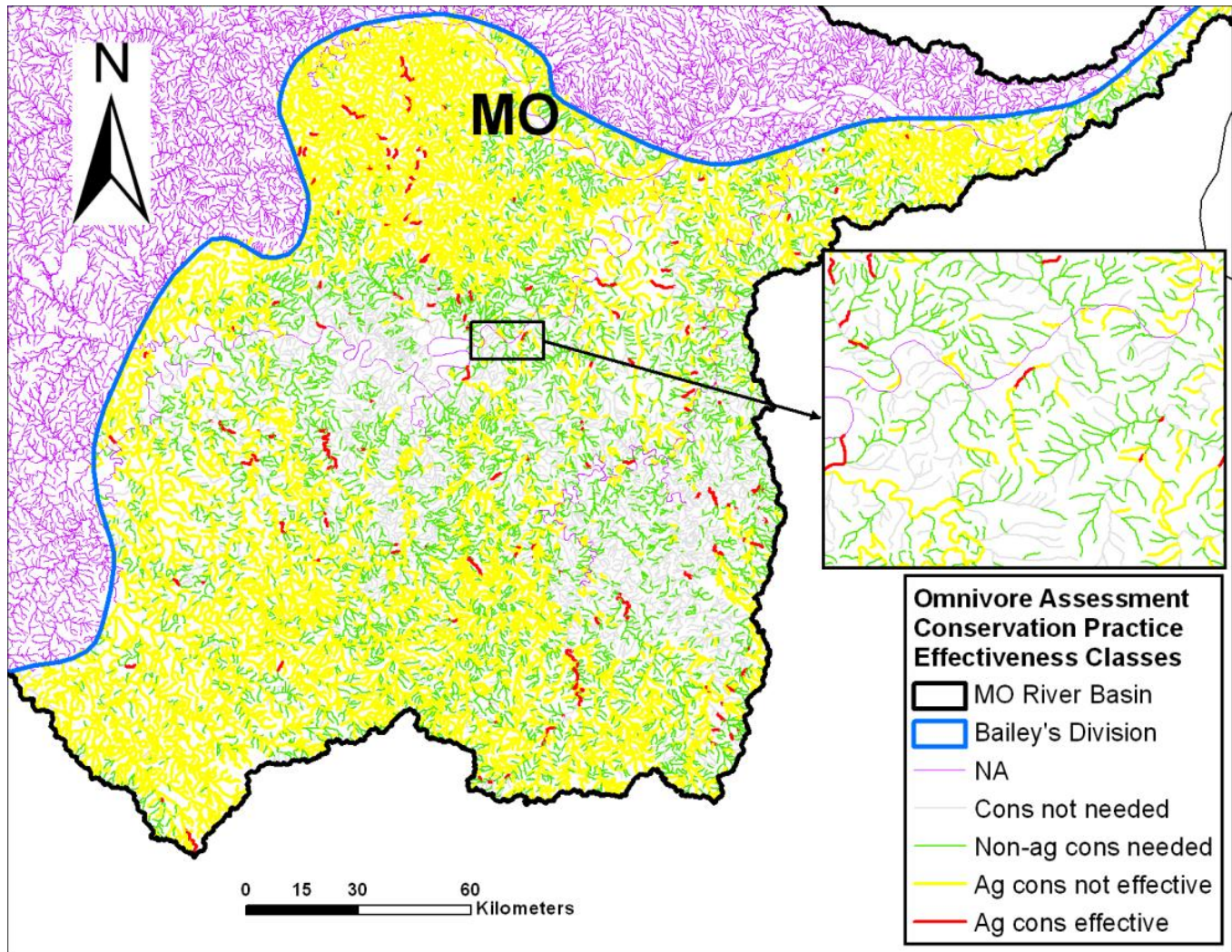

Figure 3.6. Map of stream segments in stream segments <500 link magnitude classified into predicted conservation practice effectiveness groups in the Prairie and Hot Continental Divisions of the Missouri River basin. Omnivores were used as an indicator. Refer to Table 3.11 for criteria used to delineate conservation practice effectiveness groups. NA refers to streams too large for assessment (link magnitude >500).

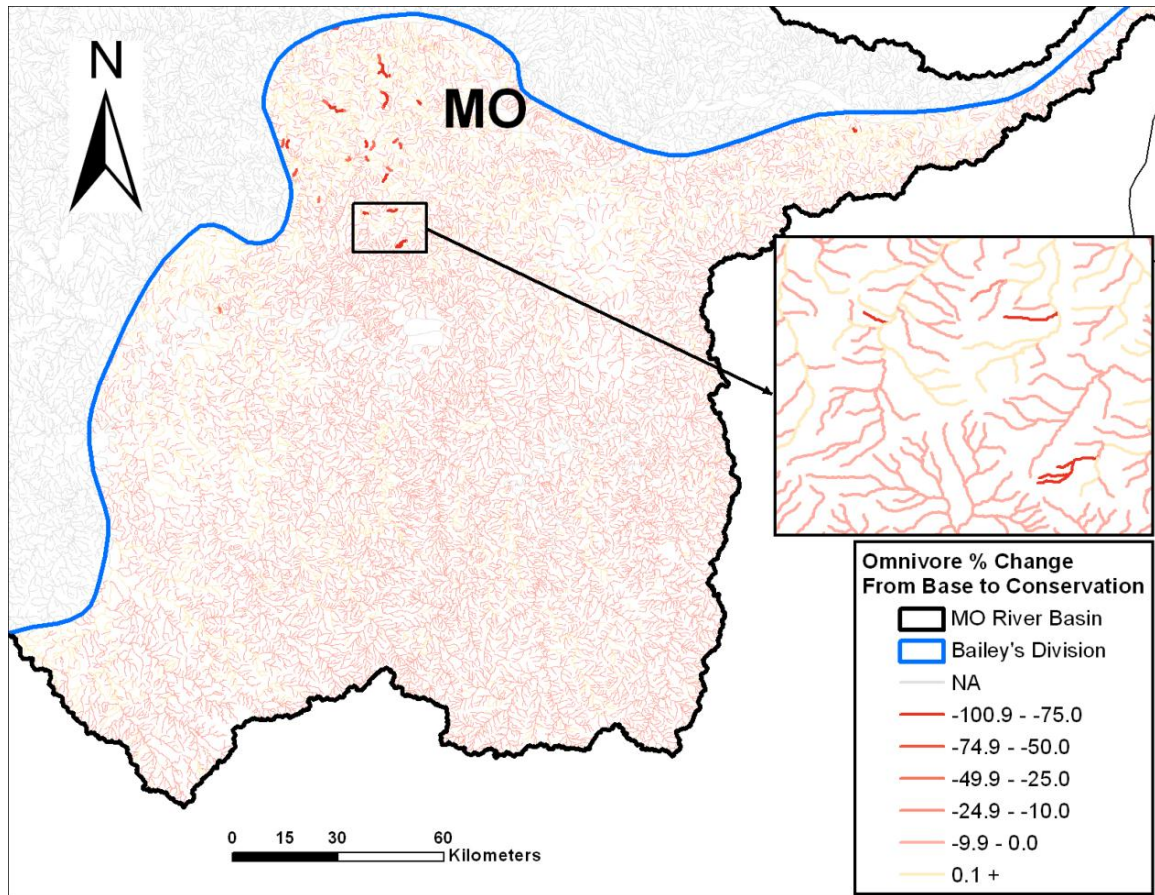

Figure 3.7. Predicted percent change in lithophil guild abundance from base condition abundance to conservation condition abundance for stream segments with link magnitude <math>< 500</math> in the Prairie and Hot Continental Division of the Missouri River basin. Base condition abundance was predicted assuming no conservation practices were applied on the landscape and conservation condition abundance accounted for the effects of currently applied NRCS soil conservation practices. Negative values indicate positive conservation practice effects because omnivore abundance was expected to decline in response to conservation practice density.

CHAPTER 4 - FRAMEWORK TO IMPROVE AGRICULTURAL CONSERVATION EFFORTS: REDUCING POTENTIAL COSTS AND INCREASING ECOLOGICAL EFFECTIVENESS

Abstract

Successful agricultural conservation will be necessary to reduce ecological degradation of aquatic ecosystems. Current research indicates that agricultural conservation efforts by U.S. Department of Agriculture's Natural Resource Conservation Service (NRCS) have been effective and that additional efforts will be required to improve the ecological condition of many watersheds. Declining conservation funding coupled with reduced producer participation in cost-share programs has created a greater demand for agencies like NRCS to strategically distribute conservation resources in an effort to maximize the ecological benefits of their conservation programs. We developed a decision support framework to improve the allocation of conservation resource and to increase the ecological effectiveness of agricultural conservation practices for private lands at regional and watershed spatial scales. The framework is comprised of three components designed to strategically identify watersheds where: 1) ecological degradation has occurred, 2) CPs are likely to be effective, and 3) the cost-benefit ratio of implementing CPs is lowest. A case study in the Missouri River basin is presented to demonstrate how the framework can be used. We identified 2,633 ecologically degraded watersheds where agricultural conservation practices were likely to be effective. Agricultural conservation practices designed to prevent soil disturbance (e.g., conservation tillage and grazing management), and thus erosion, were more cost-effective than practices designed to prevent eroded materials from entering stream channels (e.g.,

crop rotations). Cost-benefit ratios and total conservation costs differed substantially by ecoregion. Due to the likelihood that a high density of conservation practices are needed to improve ecological conditions from 'more' disturbed to reference conditions, managers should strategically allocate resources to watersheds at multiple spatial scales and actively seek producers willing to participate in cost-shared agricultural conservation practices to maximize ecological return on conservation investments.

Chapter 4 - Summary of Management Opportunities, Use Limitations, and Improvement Options for Framework to Improve Agricultural Conservation Efforts: Reducing Potential Costs and Increasing Ecological Effectiveness

Opportunities to Use the Decision Support Framework

- Strategically allocate conservation resources to improve fish assemblage condition by prioritizing stream segments in need of agricultural conservation.
 - identify stream segments where fish assemblages are likely degraded (i.e., where conservation is most needed).
 - identify segments where agricultural CPs are most likely to be effective.
 - identify CPs with lowest marginal costs (i.e., have the greatest ecological benefit and least cost).
 - **estimate total conservation costs and cost-benefit ratio of implementing CPs to restore or maintain desired fish assemblage conditions.**

Limitations and Caveats of the Decision Support Framework

- Cost estimates for watersheds do not necessarily represent the full installation and maintenance costs.
- Standardized CP scenarios were used to relativize comparisons among watersheds and to improve presentation; specific conservation needs are likely to vary among watersheds.
- Actual conservation cost estimates for watersheds may vary because our cost estimates were averaged among several states and relativized to ecoregion (Hot Continental and Prairie Divisions).
- Conservation practice data are outdated (1999 – 2008) and must be continually updated to ensure contemporary accuracy.

Options for Improvements

- Develop the decision support framework into a customized desktop or online version of an ArcGIS project that allows users to evaluate CP scenarios, their cost, and how they affect watershed conditions.
 - continual updating of applied CP data and CP costs.
 - integrate with the NRCS Practice Data and/or Cropland Assessments to generate a continual update of practice data and a reassessment of progress toward fish assemblage conservation goals.

Introduction

Improving the effectiveness of conservation efforts on agricultural lands will be critical to solving large-scale ecological problems like hypoxia in the Gulf of Mexico (Malakoff 1998; Rabalais and others 2002) as well as smaller-scale issues like sedimentation of headwater streams (Waters 1995). About 70% of the land in the U.S. is privately owned (Gray and Teels 2006) and 50% of that land is under agricultural production (Heard and others 2000). The Midwest U.S. contains some of the most productive cropland in the world, with landuse in many watersheds consisting almost entirely of crop production (Monfreda and others 2008). The major stressors from agricultural production are sediment loading of waterways, altered hydrology, and nutrient runoff. Sedimentation from agriculture is considered the largest pollutant to freshwater ecosystems (US Environmental Protection Agency 2000b; Waters 1995) and is a major threat to aquatic communities (Newcombe and MacDonald 1991; Wood and Armitage 1997). The public has recognized these issues and has widely supported conservation on agricultural lands aimed at improving water quality and ecological services (e.g., reducing sedimentation, pesticide runoff, and nutrient runoff to surface waters).

Agricultural conservation policy in the U.S. is largely accomplished through the Farm Bill and its conservation programs are administered on private agricultural lands by U.S. Department of Agriculture's Natural Resources Conservation Service (NRCS). NRCS is one of the few agencies to work with private agricultural producers to implement conservation practices (CPs) and is the agency most likely to accomplish agricultural conservation over large geographic scales. The original 1985 Farm Bill set out to reduce erosion on highly erodible lands and to reduce excess food production by

idling marginal croplands. Agricultural conservation policy has since evolved to place less focus on decreasing food production and now focuses on providing environmental benefits through water quality improvements and increasing wildlife habitat (Heard and others 2000). Today, NRCS provides technical assistance to agricultural producers by cost-sharing conservation practices that range from wetland and upland restoration, to improved tillage practices, and better management of nutrient and pesticide applications. Producers voluntarily enroll in the Conservation Reserve Program by submitting contracts to local NRCS offices. NRCS staff then use indices to prioritize the contracts and incentive payments based on highly erodible lands, potential water quality improvements, and wildlife habitat value (Walter and others 2007).

Current research suggests agricultural conservation efforts on private lands have provided environmental benefits but these benefits are often localized and fragmented and broader scale benefits will require large increases in CP implementation (Fore Chap. 2). Due to CPs implemented in the Upper Mississippi River basin, sediment loss from fields was estimated to be reduced by 69% and total nitrogen loss was reduced by 48% (U.S. Department of Agricultural, unpublished report). Similarly, in the Great Lakes region, sediment loading to rivers was estimated to be reduced by 50% and nitrogen loading by 38% (US Department of Agriculture 2011). However, both studies indicated that more CPs were needed on highly erodible lands. Sediment loading would be reduced by 11% if the 3.4 million hectares of highly erodible land and by 26% if all 14.5 million hectares of under-treated lands in Upper Mississippi River basin were treated with soil erosion practices. Similarly, implementing soil CPs on the 1.1 million hectares of highly erodible lands in the Great Lakes region would reduce sediment loading by

30%. Unfortunately, because enrollment in CPs is voluntary, NRCS has limited abilities to seek out producers or specific fields to strategically implement CPs.

NRCS conservation practices provide ecological benefits to terrestrial wildlife, primarily avifauna, by idling cropland and restoring grassland habitat (Burger, Jr. and others 2006; Ryan 2000; Schnepf and Cox 2006). Retiring croplands with the Conservation Reserve Program and planting perennial vegetation increased nest success and recruitment for five duck species in the Prairie Pothole region of the U.S. and resulted in an additional 12.4 million recruits (Reynolds and others 2001). Additionally, the Conservation Reserve Program has been cited as an important source habitat for multiple species of grassland nesting birds (McCoy and others 1999). Agricultural (e.g., contour farming and reduced tillage) and riparian CPs have been shown to improve physical stream habitat (i.e., an aggregate habitat index score), and the effects to fishes are varied but intolerant individuals generally declined in abundance with CP installation (Wang and others 2002). Lithophilous spawning fishes sensitive to impacts of stream sedimentation were positively associated with NRCS soil CPs (Fore Chap. 3). Positive ecological benefits to fishes were not commonly observed because the density of CPs within individual watersheds was too low to elicit a response (Fore Chap. 3). This research indicates that if improvements in ecological condition are desired outcomes of agricultural conservation efforts that the distribution and placement of CPs will need to be improved.

Agricultural conservation is a complex endeavor that requires planning at multiple spatial scales. Most recommendations for improving conservation strategy deal with increasing the precision at which we address conservation issues; for example,

identifying highly erodible lands or those considered hydrologically sensitive on individual farm fields can focus conservation efforts on areas most likely to contribute pollution (Walter and others 2000). Indeed, these advances in precision agriculture can be effective at reducing pollution (Delgado and others 2011) and producers can maintain or increase profitability (McConnell and Burger 2011). The downside to these methods is that they generally require intensive scientific investigation that producers are unable to perform and they often ignore larger patterns of regional conservation need.

It is important for conservation to have local support, but strategic planning should begin at coarser spatial scales such as ecoregions or watersheds. Distributing conservation funding similarly among political boundaries increases the likelihood that conservation will be less effective because water resource issues are bounded by ecoregions and watersheds. When using watersheds as the spatial unit to distribute conservation funds, managers can strategically allocate funding based on cost criteria because they can better estimate the amount of conservation needed to reduce ecological degradation. Once funding is properly allocated among watersheds, local and precision agricultural conservation could then be utilized to determine the best method to meet conservation objectives (Walter and Walter 1999).

Managers need information and decision support tools to aid them in strategic selection of conservation watersheds (Pullin and Knight 2003; Walter and others 2007). Decision support frameworks provide managers a means to formally incorporate scientific knowledge and evidence into the decision making process (Pullin and others 2004). The framework should be structured so that managers can incorporate stakeholder values into objectives that reflect desired and achievable conditions (Clemens and Reilly

2001; Keeney 1996). Decision support frameworks are also beneficial because they reduce aversion to taking management risks, yet allow managers to incorporate and account for uncertainty in the decision making process (Maguire 1991; Regan and others 2005). Conservation funding is always limited and managers are required to maximize its use by providing the greatest return for each conservation investment. Decision frameworks should be used by managers to make strategic decisions regarding conservation resource distribution. Incorporating three strategic elements – ecological prioritization, maximization of CP efficacy, and cost analysis – into a decision support framework for agricultural conservation will allow managers to make informed decisions that best utilize limited conservation resources and increases ecological benefits.

Our goal was to develop a decision support framework that improves conservation resource allocation and ecological effectiveness of agricultural conservation practices for private lands at regional and watershed spatial scales. We generally refer to conservation resources as funding for implementing CPs, but it also includes the funds required for general administrative and technical tasks that coincide with implementing a conservation practice. A case study in the Missouri River basin is used to illustrate how NRCS could implement this framework (and use the associated data and models presented in chapters 2 and 3) to allocate financial resources and agricultural conservation practices to improve fish assemblage condition. The decision support framework is intended to be flexible and because our case study is used an illustration, managers can, and should, adapt methods that best suit their needs.

The framework we apply is used as a winnowing process (Claassen 2007) that includes all producers and land area in a region (Fig. 4.1). Since the goal is to

strategically identify a subset of watersheds, each component of the framework is designed to reduce the larger subset to an idealized (as determined by a manager) group of watersheds. The framework is comprised of three components designed to strategically identify watersheds where: 1) ecological degradation has occurred (see Fore Chap. 3, Figure 3.4), 2) CPs are likely to be effective (see Fore Chap. 2, Figure 2.6), and 3) implementing CPs are cost-effective. The components of the framework are outlined below.

Allocate conservation resources to watersheds exhibiting ecological degradation

Managers may consider prioritizing watersheds based on ecological need so that conservation resources are utilized in watersheds where degradation has occurred. By using biological criteria to define reference conditions (the desired condition after conservation has occurred), managers can empirically estimate (via models) current baseline ecological condition in unsampled watersheds (Fig. 4.1; step 1). The major decision point in this step is to determine what constitutes ecological degradation and to select watersheds considered ecologically degraded for conservation (Fig. 4.1; step 1). Additionally, the models can also be used to explore relationships between biota and CPs so that the amount of conservation effort needed to reach reference condition can be estimated. Estimating the amount of conservation needed to achieve reference condition is critical for two reasons: 1) to compare the amount of conservation effort needed among watersheds and 2) to estimate the total conservation cost and cost-benefit of reaching the conservation targets for each watershed.

Increase the likelihood conservation practices are effective

Conservation agencies are likely to be more effective if they seek watersheds relatively homogenous in threats because these agencies generally work independently and their CPs only address a specific suite of threats (e.g., agriculture but not point-source pollution). Doing so requires conducting a formal threat assessment in an effort to maximize the potential ecological benefits derived from the practices and ensures conservation resources are appropriated to the proper watersheds (Fig 4.1; step 2). These watersheds can be identified if we operate under the premise that CPs are less effective in watersheds with a high prevalence of threats that the agency's CPs were not designed to mitigate (non-target threats) (Fore Chap. 2). The prevalence of non-target threats is not always self-evident when examining landcover maps because multiple threats generally affect most watersheds (Fore Chap. 2). Therefore, it is essential managers conduct threat assessments to determine the relative proportion of a watershed's target and non-target threats to identify watersheds where conservation practices are most likely to be effective without implementing CPs that address non-target threats (Fig. 4.1; step 2).

Make best use of conservation funding

Managers can use financial information to strategically utilize conservation resources in a manner that saves money and maximizes ecological benefits. At this point, a subset of watersheds has been identified that are ecologically degraded and contain threats best suited to the agency's CPs, which should increase the likelihood of conservation success. The major task in this step is to determine for each watershed the cost of implementing CPs to achieve reference conditions (Fig. 4.1; step 3). Watersheds can be strategically identified by estimating the total cost of CPs needed to achieve the

reference condition, by estimating the cost-benefit ratio of each watershed, or some combination of both approaches. Estimates of cost-benefit ratio for each watershed are expressed as dollars per unit of ecological gain (e.g., dollars per unit increase of fish guild abundance) and allow managers to avoid watersheds where CP implementation yields little ecological benefit and poorly appropriates limited conservation resources. The major decision point for this step is to develop cost criteria that use some combination of total cost and cost-benefit ratio to allocate conservation funding to watersheds (Fig. 4.1; step 3).

Methods

Study Area

The case study was performed in two ecoregions of the Missouri River basin, the Prairie Division and Hot Continental Division that are in the Humid Temperate Domain (Fig. 4.2) (Bailey 1980; Bailey 1983). Our case study was restricted to these ecoregions because prior research was conducted in them that assessed fish assemblage response to the implementation of NRCS CPs. The Prairie Division is typically associated with climates in which soil and air temperatures are high in summer and soil moisture is insufficient for tree growth. Vegetation consists of tall grasses with subdominant broad-leaf herbs. Woody species are generally absent. Soils are Mollisols, rich in organic matter. The Hot Continental Division is characterized by hot, humid summers with cool winters. Dominant vegetation is deciduous forest, with a low shrub layer, and understory of herbs in early spring. Soils are primarily Inceptisols, Utisols, and Alfisols.

General Methods

Allocate conservation resources to watersheds exhibiting ecological degradation

Watersheds in this study are represented by the stream segment of the watershed outlet. Multiple-regression models were developed to predict lithophil guild abundance and identify ecologically degraded watersheds (Table 4.1, Fig. 4.3). Lithophil guild abundance was predicted as the proportion of lithophilous species in a stream segment as a function of total watershed conditions. Models were developed for each ecoregion and were applicable to streams with a link magnitude less than 500. A three-step modeling procedure was used to account for the effects of physiography, human threats, and soil CPs (Table 4.2). Physiographic features were used to account for natural variation in lithophil guild abundance and human threat indices were used to account for contemporary watershed condition and its effect on lithophil guild abundance (Table 4.2). Three soil CP scenarios were used to identify how lithophil guild abundance responded to agricultural CPs (Table 4.2). One CP scenario represented practices designed to reduce soil disturbance. Two CP scenarios represented practices designed to reduce sedimentation and they were distinguished by practices implemented on an area basis (hectares) and practices implemented linearly (meters) (Table 4.2). Accounting for the effects of soil CPs allowed us to assess whether CP implementation improved fish assemblages from 'more' disturbed to reference conditions (i.e., ecologically degraded watersheds were improved to reference condition).

Two predictions of lithophil guild abundance from the multiple-regression model and a reference condition threshold were used to classify stream segments as ecologically degraded. 'Base' abundance was predicted by setting CP density in all watersheds to

zero and was used as a baseline to evaluate how implementation of soil CPs affected fish assemblages (Table 4.1, Fig. 4.3). ‘Conservation’ abundance was predicted by accounting for the density of currently applied CPs and was used to assess how soil CPs affected fish assemblages relative to base abundance and reference conditions (Table 4.1, Fig. 4.3). The threshold for ‘reference’ conditions was calculated separately for each ecoregion as the mean lithophil guild abundance from fish samples where agricultural and non-agricultural threat index scores were below the 50th percentile (Table 4.1). Watersheds were then classified as ecologically degraded if base and conservation abundances were below the reference condition threshold (i.e., more disturbed) because lithophils guild abundance was expected to increase with CP density (Fig 3.3). Watersheds with base abundance less than reference condition and conservation abundance greater than reference condition were not included because agricultural conservation was considered effective. The reference condition criteria are used here as an illustration. Different reference criteria should be used to suit the needs and goals of an agency.

Increase the likelihood conservation practices are effective

A threat assessment was conducted to determine watersheds under NRCS primary management capacity (Table 4.1, Fig. 4.4). Soil CPs would be more likely to be effective (at increasing lithophil guild abundance) in watersheds where NRCS primary management capacity. To conduct the threat assessment, agricultural and non-agricultural threat indices were constructed by calculating the total watershed prevalence for 17 threat metrics (Table 4.2, Fig. 4.4) (Fore Chap. 2). The individual threat metrics

were standardized relative to the watershed with the highest threat metric prevalence and were transformed to a common scale because prevalence units differed among metrics (Table 4.1) (Fore Chap. 2). The threat indices were calculated by summing their corresponding standardized threat metrics and were transformed to a common scale so that comparisons could be made across the indices (Table 4.1) (Fore Chap. 2). NRCS primary management capacity was determined by giving each watershed a quartile score for its agricultural and non-agricultural threat index score (Table 4.1; e.g., a threat index score = 0 – 25 yielded a quartile score = 1). The agricultural quartile score was then divided by the non-agricultural quartile score to yield a NRCS primary management capacity score (Table 4.1, Fig. 4.4). Stream segments with scores ≥ 2 were considered to be under primary NRCS management capacity (Table 4.1) (Fore Chap. 2).

Make best use of conservation funding

Determining *total conservation cost* for each watershed was accomplished by calculating three variables: 1) *conservation need* – the increase in guild abundance needed to reach reference condition, 2) *CP scenario density* – the density in square kilometers of each CP scenario to meet conservation need, and 3) *CP scenario cost* – the marginal cost (cost per unit) of each CP scenario per hectare (Table 4.1, Fig. 4.5). We calculated *conservation need* for individual watersheds as the difference between reference condition threshold and base abundance (Fig. 4.5). *Conservation practice scenario density* was calculated using the parameter estimates from the multiple-regression model that predicts lithophil guild abundance (Fig. 4.5). A look-up table was developed that represented the minimum *CP scenario density* needed to increase guild

abundance by units of 0.01. The look-up table was used for each watershed to link the *conservation need* field to *CP scenario density* field. The *CP scenario density* was represented in the multiple-regression model as a proportion of total watershed area, and we converted the proportions to hectares for each watershed so that total conservation costs could be estimated.

Conservation practice scenario cost was calculated independently for each ecoregion as

$$CP \text{ scenario cost} = \sum CP_{cost} \times P_{CP}$$

where CP_{cost} is the mean cost (\$USD) for each CP type that composes a scenario and P_{CP} is the percentage each CP type was implemented within an ecoregion (Fig. 4.5). Cost data were obtained from NRCS's electronic Field Office Technical Guide (US Department of Agriculture 2012) and averaged across the states of Nebraska, Missouri, Kansas, South Dakota, and North Dakota to estimate CP_{cost} (Table 4.2). Each CP scenario contains multiple CP types and their implementation rates vary, which could be problematic when estimating the CP scenario costs. To account for the variable implementation rates and to calculate P_{CP} we assumed that for each CP scenario, every hectare of CP scenario would be implemented relative to each CP type's implementation rate within the ecoregion.

Total conservation cost was then calculated by multiplying *CP scenario density* by *CP scenario cost* for each watershed (Table 4.1, Fig. 4.5). Cost-benefit ratio was calculated by dividing *total conservation cost* by the number of 0.01 units of *conservation need* for each watershed (Table 3.1, Fig. 4.5).

Case Study

Following step 1 of the decision support framework, we identified ecologically degraded watersheds by using a reference condition threshold and the base abundance and conservation abundance estimates from the multiple-regression models. Watersheds that had base and conservation abundance values less than the ecoregion's reference condition threshold were selected as a subset of all eligible watersheds (link magnitude < 500) within the ecoregion (Figs. 4.1 and 4.2).

From the subset of watersheds selected in step 1, we selected watersheds where NRCS had primary management capacity (agricultural threats approximately twice as prevalent as non-agricultural threats) (Figs. 4.1 and 4.3).

Total conservation cost and cost-benefit ratio were calculated in step 3 of the decision support framework for the remaining subset of watersheds (Fig. 4.5). Two aggregate CP scenarios were used in this study because the reduce sedimentation scenario that was applied linearly (as identified in the *General methods* section) was negatively related to lithophil guild abundance; therefore, the scenario could not increase lithophil guild abundance to reference conditions. One CP scenario was comprised of practices designed to reduce soil disturbance and erosion (hereafter 'reduce soil disturbance') (Table 4.3). The other CP scenario was comprised of practices designed to reduce sediment entering stream channels (hereafter 'reduce sedimentation') (Table 4.3). We also calculated a scenario that combined the effects of the reduce soil disturbance and reduce sedimentation scenarios (hereafter 'reduce disturbance and sedimentation'); therefore, this scenario assumes if a watershed needed 50% of its area implemented in CPs, that both scenarios were implemented in 50% of the watershed, not 25% of each

scenario. To simplify the presentation of total conservation costs, we estimated conservation costs assuming that each CP scenario was implemented irrespective of the other practice scenarios.

Cost-benefit ratios were calculated for each watershed and we calculated the 10th, 15th, 25th, 50th, and 75th percentiles to give managers a range of cost-benefit ratios to select (Fig. 4.5). The percentiles were calculated within each ecoregion to compare watersheds within each ecoregion (independent of the other) and independent of ecoregions so the watershed comparisons could be made among both ecoregions.

Results

The first step of the framework was to identify watersheds exhibiting ecological degradation. In the entire study area, 17,320 watersheds (13.8%) were classified as ecologically degraded; that is they were predicted to have values of lithophil guild abundance less than guild abundance value for reference conditions (Fore Chap. 3). Of those, 2,269 (13%) were in Hot Continental Division with the remainder in Prairie Division (87%). The number of ecologically degraded watersheds in Hot Continental Division represented 10.6% of the total watersheds in that ecoregion and the 15,051 ecologically degraded watersheds in Prairie Division represented 14.4% of watersheds in that ecoregion.

From the above subset of watersheds, we identified those where NRCS CPs were most likely to be effective; that is, NRCS had primary management capacity (Fore Chap. 2). We identified 2,663 (15%) watersheds in both ecoregions where NRCS had primary management capacity in ecologically degraded watersheds. Both criteria (i.e., watersheds were ecologically degraded from agriculture and were under NRCS management

capacity) were met in 694 Hot Continental Division watersheds (3% of all watersheds in Hot Continental Division) and in 1,964 watersheds in Prairie Division (2% of all watershed in Prairie Division). We excluded 329 watersheds because they needed less than a 0.01 increase in lithophil guild abundance to reach the least disturbed threshold; it was assumed their abundance was close enough to the threshold that conservation was not likely needed.

The composition of the CP scenarios differed between ecoregions. The reduce soil disturbance scenario in Hot Continental Division was dominated by terrestrial habitat restoration CPs and grazing management CPs (Table 4.4). Conservation tillage practices were implemented in Hot Continental Division, but were generally uncommon. The reduce soil disturbance scenario in Prairie Division was dominated by conservation tillage practices (Table 4.4). Grazing management practices (use exclusion and prescribed grazing) and upland habitat management practices in Prairie Division were implemented in nearly equal densities in the reduce soil disturbance scenario (Table 4.4).

Conservation practices with the lowest marginal costs (cost per unit) in the reduce soil disturbance scenario were residue and tillage management, mulch-till, prescribed grazing, and use exclusion. Conservation tillage and grazing management practices had lower marginal costs than practices involving restoration or retiring land from production (Table 4.4). The conservation cover practice was excluded from the reduce soil disturbance scenario cost estimate in Prairie Division because cost information for this practice could only be obtained for one of the five states (South Dakota). Had we included this practice in the scenario, the scenario's cost would have been five times higher than the cost reported in Table 4.4.

The composition of the reduce sedimentation scenarios was very similar between the two ecoregions. Conservation crop rotation was the most commonly implemented practice in both ecoregions and contour farming was the second most commonly implemented practice (Table 4.4). The only major difference between the ecoregions was seasonal residue management practices were more commonly implemented in Hot Continental Division (Table 4.4).

Conservation practice types with the lowest marginal costs in the reduce sedimentation scenario were those designed to change production operations, while CPs with restoration components had higher costs (Table 4.4). Residue management, mulch tillage, and conservation crop rotations had the lowest marginal costs while riparian zone restoration and grassed waterway practices had the highest marginal costs (Table 4.4).

The total cost of both scenarios was similar within each ecoregion (Table 4.4). However, among ecoregions, the reduce soil disturbance scenario cost about twice as much in Hot Continental Division as it did in Prairie Division and the reduce sedimentation scenario cost was more than three times as much in Hot Continental Division as it did in Prairie Division (Table 4.4). The reduce disturbance and sedimentation scenario cost \$48,706/km² in Hot Continental Division and \$18,226/km² in Prairie Division; its cost was estimated by summing the marginal cost of the reduce soil disturbance and reduce sedimentation scenarios.

The average predicted increase in guild abundance needed to shift watersheds from more to less disturbed was generally low. On average, the mean lithophil abundance increase needed for watersheds in Hot Continental Division was 0.08, and

ranged from 0.01 to 0.38 (Fig. 4.6). In Prairie Division, the mean lithophil abundance increase needed was 0.05, and ranged from 0.01 to 0.22 (Fig. 4.6).

The average total cost of implementing CPs to reach least disturbed conditions (hereafter, total conservation cost) was greater in the Prairie Division for all CP scenarios (Table 4.5). The average total conservation cost of the reduce soil disturbance scenario was lowest in both ecoregions (Table 4.5; Fig. 4.7), whereas total conservation cost for the reduce sedimentation scenario (Fig. 4.8) was on average intermediate in both ecoregions and the reduce disturbance and sedimentation scenario was highest in both ecoregions (Table 4.5; Fig. 4.9).

Percentiles for cost-benefit ratio were examined across the entire assessment area, irrespective of ecoregion. The reduce soil disturbance scenario had lowest cost-benefit ratio across the study region (Table 4.6; Fig. 4.10). The reduce sedimentation scenario was intermediate in cost-benefit ratio (Fig. 4.11) and the reduce disturbance and sedimentation scenario had the highest cost-benefit ratio (Table 4.6; Fig. 4.12). Examining the mapped output indicates that the most cost-effective ecoregion for fish conservation was Hot Continental Division (Figs. 4.10, 4.11, and 4.12). The Prairie Division had few watersheds with low cost-benefit ratios using the reduce soil disturbance scenario as most were in Hot Continental Division (Fig. 4.10). The watersheds with the lowest cost-benefit ratios for the reduce sedimentation scenario were primarily in Hot Continental Division but several were present in Prairie Division (Fig. 4.11). The pattern for cost-benefit ratios of the reduce disturbance and sedimentation scenario was similar to the reduce sedimentation scenario (Fig. 4.12).

There were differences in cost-benefit ratio for watersheds within each ecoregion. Within Hot Continental Division, the reduce soil disturbance scenario was expected to have the lowest cost-benefit ratio (Fig. 4.13), the reduce sedimentation scenario was intermediate in cost (Fig. 4.14), and the reduce disturbance and sedimentation scenario cost the most (Table 4.5; Fig. 4.15). In Prairie Division, the reduce sedimentation scenario had the lowest cost-benefit ratio (Fig. 4.14), the reduce soil disturbance scenario was intermediate in cost (Fig. 4.13), and the reduce disturbance and sedimentation scenario cost the most (Table 4.5; Fig. 4.15). Cost-benefit ratio percentiles were always less in Hot Continental Division than those in Prairie Division, indicating that conservation in Hot Continental Division as a whole is has the best cost-benefit (Table 4.5).

Discussion

Shrinking funds for fish and wildlife conservation efforts will put increasingly more pressure on managers and policymakers to maximize the use of the conservation funds to achieve ecological benefits. Because our framework involves estimating conservation costs, managers will have a tool to help them justify the distribution of conservation resources among watersheds and they will be able to influence policies to gain additional support for ecological conservation. Although not all NRCS conservation initiatives are targeted at improving ecological condition, this framework could also be used by NRCS to strategically select watersheds for their Environmental Quality Incentives Program (EQIP) that focuses on improving biological or ecological condition. Because funding for programs like EQIP is limited, we argue agencies would be best served by strategically selecting watersheds based on three tenets: 1) mitigating for

ecological degradation is more likely to result in improved water quality, 2) the effectiveness of CPs can be maximized by conducting threat assessments, and that 3) funding can be effectively allocated by estimating total conservation cost and cost-benefit ratio of implementing CPs.

Using ecological criteria to strategically select watersheds would increase the effectiveness of programs like EQIP. Biota reflect stream condition better than physical or chemical parameters because they integrate all aspects of their physiochemical environment (Karr 1999; Karr and Chu 2000). If water quality parameters are used as benchmarks for conservation success, it is possible for water quality restoration to be ‘successful’ but biological conditions remain degraded. For example, the sediment load in some watersheds is 12 times historical levels (Kelley and Nater 2000); if conservation success was defined by a 25% reduction in sediment loading and the criterion was met, the sediment load would still be nine times historical loads and could be insufficient to improve biological life. NRCS CPs are generally implemented to provide environmental benefits (e.g., reduced sediment loading and nutrient runoff), but to the best of our knowledge, are generally not implemented with the intent of making quantitative improvements to water quality parameters or ecological condition. Our decision support framework and supporting models (from Fore Chapters 2 and 3) can be used, as our case study demonstrates, as a means for NRCS to use quantitative ecological conditions as conservation outcomes as a means to implement CPs in watersheds. Doing so increases the likelihood that conservation efforts will result in water quality improvements because the amount of CPs will be scaled to ecological improvements, not water quality parameters.

Managers stand to benefit by selecting watersheds that maximize the effectiveness of their conservation practices. The unfortunate reality of conservation is that most agencies generally work independently; therefore, it may be ideal for an agency to focus their efforts in watersheds where collaborative management is less likely to be needed. It would be less productive for a management agency to implement agricultural practices in the upper end of a watershed that drains predominantly urban land; the stresses from urbanization would likely degrade ecological condition and therefore render the implementation of agricultural CPs ineffective at improving biological condition (Steffy and Kilham 2006; Wang and others 2001). A large number of watersheds within agricultural regions are impacted by non-agricultural threats (Fore Chap. 2). Programs like EQIP that have large priority watersheds could increase agricultural CP effectiveness by identifying and working in subwatersheds (within the priority watershed) that are minimally impacted by non-target threats. Demonstrating the effectiveness of conservation practices to producers is likely to increase their involvement in conservation programs and should lead to increased CP adoption and ecological benefits (Luzar and Diagne 1999; Prokopy and others 2008).

Accounting for the total conservation costs and cost-benefit of conducting conservation will improve utilization of limited conservation resources and ideally result in improved conservation effectiveness. The framework presented here is intended to provide managers flexibility in assessing the cost-benefit of differing conservation options. Managers could simply target the “low-hanging fruit” and invest in watersheds where total conservation cost is lowest. Alternatively, they could target watersheds with the lowest cost-benefit ratio so that some conservation (i.e., least disturbed conditions are

not achieved) could be achieved in a larger number of watersheds. For example, conservation funds could be distributed to watersheds below the 10th or 25th cost-benefit percentile to achieve a specified increase in guild abundance, regardless of total cost. Alternatively, managers can use this framework to identify streams so severely degraded that restoration or rehabilitation is unlikely to be successful because costs are too prohibitive. Funding could also be prioritized by ecoregion or to individual watersheds (independent of ecoregion). In the Missouri River basin case study, watersheds in Hot Continental Division generally required less total conservation funds to reach least disturbed conditions and their cost-benefit ratios were nearly always an order of magnitude lower than watersheds in Prairie Division. If a program's goal was to simply gain as much conservation as possible (i.e., increase lithophil abundance) with the least amount of conservation resources, then funding conservation in Hot Continental Division would likely yield the highest return relative to Prairie Division. Additionally, this analysis also highlights the need to increase funding opportunities in highly threatened ecoregions like the Prairie Division because the total costs of conservation are so high.

Prioritizing watersheds based on total costs or cost-benefit ratio requires making tradeoffs. Funding watersheds based on lowest total cost may conserve funding, but it is likely that they cost less because they need small increases in guild abundance. Managers would need to weigh the tradeoff of investing their resources in sites that are marginally degraded or those exhibiting greatest conservation need. The benefit of strategically selecting watersheds using the cost-benefit ratio is that ecological returns are larger per investment in conservation. Another benefit of this approach is that watersheds with low cost-benefit ratios should represent those where conservation is most effective

because they respond to small efforts of CP implementation. However, the primary issue with only using cost-benefit ratio is that it is expressed as a marginal cost, and the total conservation cost for a given watershed is ignored. This could lead to inappropriate distribution of conservation resources because of the large resource commitment to watersheds with high total costs. Therefore, it is advisable for managers to recognize tradeoffs in using cost-benefit ratios and to develop criteria that maximize the effects use of their funds.

Alternative options for prioritization of conservation on agricultural lands include protecting areas of low ecological degradation and continuing cost-share payments to producers in watersheds where current and past conservation efforts have improved (or maintained) ecological condition. Although our decision support framework was not formulated to identify these streams, additional components could be added to this framework to identify stream segments where current conservation efforts could be retained for ecological benefit. Fore (Chap. 3) identified streams where currently implemented agricultural CPs were predicted to reduce ecological degradation (in Fore Chap. 3 streams classified as “agricultural conservation effective”) and these could be targeted for protection or recurring cost-share payments. In those watersheds, and by using the methods outlined in the current chapter, managers could calculate the costs required to implement the CPs and maintain current levels CP implementation by continuing to allocate funding to the watersheds.

Utilizing CP types with low marginal costs and low cost-benefit ratios will increase the amount of conservation funds available for additional watersheds. We never observed a watershed where the more costly CP scenario (based on marginal costs) had a

lower total conservation cost than the least costly CP scenario. CP cost-benefit varied by ecoregions and was ultimately determined by the relationship of fish guild abundance increase to CP scenario density. CPs that were more ecologically effective on a marginal basis (i.e., resulted in larger guild abundance increases) were always more cost-effective than less ecologically effective practices. Perhaps it was coincidence, but we observed that the CP scenarios with the lowest marginal costs (from Table 4.4) were also those expected to have the greatest marginal increase in lithophil abundance (Fore Chap. 3).

Reductions in conservation funding, combined with record commodity prices and the concomitant reduction of producer enrollment in land retirement programs (e.g., Conservation Reserve Program), is likely to jeopardize the success of current and future agricultural conservation efforts. This will challenge agricultural conservation managers to maintain or increase CP enrollment rates. Most likely, the next iteration of the Farm Bill, and the agricultural conservation programs funded by it, will absorb significant cuts in conservation funding. This raises the issue of how future conservation funds will be utilized and implemented to provide ecological benefits if and when funding cuts occur. Current research suggests that the producer participation in cost-share conservation programs needs to increase (Fore Chap. 3; US Department of Agriculture 2011). Conservative estimates also suggest that current agricultural conservation efforts have largely been unsuccessful at improving fish assemblage condition because CP density is too low in most watersheds (Fore Chap. 3). CPs have the potential to be effective but need to be implemented in at least 50% (and usually more) of a stream's watershed to yield positive ecological benefits on fish communities (Fore Chap. 3). The low CP densities suggest the current policy of voluntary producer participation in agriculture

conservation programs is primarily responsible for the lack of ecological effectiveness and that if current CP enrollment trends continue, future conservation efforts will remain unsuccessful. NRCS needs the ability to strategically identify watersheds, allocate funding to those watersheds, and seek out producers who are willing to implement CPs in an effort to increase the ecological benefits provided by their conservation programs.

The efficacy of voluntary conservation programs to achieve ecological benefits has been called into question by other researchers. Some argue that for voluntary conservation efforts to be more effective, the producers need to perceive that CP implementation will increase profits and that the background threat of regulation overrides the consequences of not implementing CPs (Langpap and Wu 2004; Segerson and Miceli 1998). However, it is unlikely that producers fear the threat of regulation since there is currently no federal enforcement (though local regulation exists in some areas) of non-point source pollution from agriculture even though it is regarded as the largest pollutant source to freshwaters in the U.S. (US Environmental Protection Agency 2000a). Alternative conservation strategies are to reward farmers “green payments” for implementing CPs based on quantifiable (or estimated) reductions in agricultural pollution (e.g., nutrient export or sediment loading) (Winsten and Hunter 2011). Watershed level CP adoption rates remain low (Fore Chap. 3) even though most agricultural CPs are generally profit neutral and some increase farm profits (Valentin and others 2004). Research has shown that increasing outreach and education to producers about CP benefits (both agricultural and environmental) can positively affect CP enrollment rates (Lemke and others 2010; Prokopy and others 2008). Producers are more likely to adopt CPs when they perceive the practice will provide them an advantage (e.g.,

increased profit) and it is compatible with their current operation. Conversely, barriers to practice adoption are generally that CPs provide no perceived advantages and they are incompatible with the producer's operation (Reimer and others 2012). Integrating these principles into focused producer recruitment efforts is likely to improve CP implementation rates and ensure ecological benefits are realized.

Increasing producer participation in agricultural conservation programs will be essential if ecological benefits are a desired result of agricultural conservation. Using this framework to strategically identify would allow resources managers to actively seek program participants and potentially increase producer participation. Although enrollment in conservation programs would likely remain voluntary, the added opportunity for educating producers is likely to increase program participation and the increased conservation resources an area received would reduce contract rejections or increase the payment made to each producer. Managers can work with agricultural producers to provide ecological benefits on agricultural lands and increase the efficiency by which conservation resources are utilized.

References

- Bailey RG (1980) Description of the ecoregions of the United States. 1391, U.S. Department of Agriculture, 77 pp
- Bailey RG (1983) Delineation of ecosystem regions. *Environmental Management* 7:365-373
- Burger LW, Jr., McKenzie D, Thackston R, Demaso SJ (2006) The Role of Farm Policy in Achieving Large-Scale Conservation: Bobwhite and Buffers. *Wildlife Society Bulletin* 34:986-993
- Claassen R (2007) Buying environmental services: effective use of economic tools. In: Schnepf M, Cox C (eds), *Managing agricultural landscapes for environmental quality*. Soil and Water Conservation Society, Ankeny, IA,
- Clemens RT and Reilly T. *Making Hard Decisions with Decision Tools*. 2001. Pacific Grove, Calif, USA, Duxbury.
- Delgado JA, Khosla R, Mueller T (2011) Recent advances in precision (target) conservation. *Journal of Soil and Water Conservation* 66:167A-170A
- Gray RL, Teels BM (2006) Wildlife and Fish Conservation Through the Farm Bill. *Wildlife Society Bulletin* 34:906-913
- Heard LP, Allen AW, Best LB, Brady SJ, Burger W, Esser AJ, Hackett E, Johnson DH, Pederson RL, Reynolds RE, Rewa C, Ryan M, Molleur R, Buck P (2000) A comprehensive review of Farm Bill contributions to wildlife conservation, 1985 - 2000. Technical Report WHMI-2000, U.S.Department of Agriculture, Natural Resources Conservation Service, Madison, Mississippi, USA
- Karr JR (1999) Defining and measuring river health. *Freshwater Biology* 41:221-234

- Karr JR, Chu EW (2000) Sustaining living rivers. *Hydrobiologia* 422-423:1-14
- Keeney RL (1996) Value-focused thinking: A path to creative decisionmaking. Harvard Univ Press, Cambridge, MA,
- Kelley DW, Nater EA (2000) Historical Sediment Flux from Three Watersheds into Lake Pepin, Minnesota, USA. *Journal of Environmental Quality* 29:561-568
- Langpap C, Wu J (2004) Voluntary conservation of endangered species: when does no regulatory assurance mean no conservation? *Journal of Environmental Economics and Management* 47:435-457
- Lemke AM, Lindenbaum TT, Perry WL, Herbert ME, Tear TH, Herkert JR (2010) Effects of outreach on the awareness and adoption of conservation practices by farmers in two agricultural watersheds of the Mackinaw River, Illinois. *Journal of Soil and Water Conservation* 65:304-315
- Luzar EJ, Diagne A (1999) Participation in the next generation of agriculture conservation programs: the role of environmental attitudes. *Journal of Socio-Economics* 28:335-349
- Maguire LA (1991) Risk Analysis for Conservation Biologists. *Conservation Biology* 5:123-125
- Malakoff D (1998) Death by Suffocation in the Gulf of Mexico. *Science* 281:190-192
- McConnell M, Burger LW (2011) Precision conservation: A geospatial decision support tool for optimizing conservation and profitability in agricultural landscapes. *Journal of Soil and Water Conservation* 66:347-354

- McCoy TD, Ryan MR, Kurzejeski EW, Burger LW, Jr. (1999) Conservation Reserve Program: Source or Sink Habitat for Grassland Birds in Missouri? *The Journal of Wildlife Management* 63:530-538
- Monfreda C, Ramankutty N, Foley JA (2008) Farming the planet: 2. Geographic distribution of crop areas, yields, physiological types, and net primary production in the year 2000. *Global Biogeochem. Cycles* 22:GB1022
- Newcombe CP, MacDonald DD (1991) Effects of Suspended Sediments on Aquatic Ecosystems. *North American Journal of Fisheries Management* 11:72-82
- Prokopy LS, Floress K, Klotthor-Weinkauff D, Baumgart-Getz A (2008) Determinants of agricultural best management practice adoption: Evidence from the literature. *Journal of Soil and Water Conservation* 63:300-311
- Pullin AS, Knight TM (2003) Support for decision making in conservation practice: an evidence-based approach. *Journal for Nature Conservation* 11:83-90
- Pullin AS, Knight TM, Stone DA, Charman K (2004) Do conservation managers use scientific evidence to support their decision-making? *Biological Conservation* 119:245-252
- Rabalais NN, Turner RE, William JW (2002) Gulf of Mexico Hypoxia, a.k.a. "The Dead Zone". *Annual Review of Ecology and Systematics* 33:235-263
- Regan HM, Ben-Haim Y, Langford B, Wilson WG, Lundberg P, Andelman SJ, Burgman MA (2005) Robust Decision-Making under Severe Uncertainty for Conservation Management. *Ecological Applications* 15:1471-1477

- Reimer AP, Weinkauff DK, Prokopy LS (2012) The influence of perceptions of practice characteristics: An examination of agricultural best management practice adoption in two Indiana watersheds. *Journal of Rural Studies* 28:118-128
- Reynolds RE, Shaffer TL, Renner RW, Newton WE, Batt BDJ (2001) Impact of the Conservation Reserve Program on Duck Recruitment in the U.S. Prairie Pothole Region. *The Journal of Wildlife Management* 65:765-780
- Ryan MR (2000) Impact of the Conservation Reserve Program on wildlife conservation in the Midwest. USDA/NRCS/WHMI-2000, U.S. Department of Agriculture, Natural Resources Conservation Service, Wildlife Habitat Management Institute, 54 pp
- Schnepf M, Cox CA (2006) Environmental benefits of conservation on cropland: The status of our knowledge. Soil and Water Conservation Society, Ankeny, IA, 326 pp
- Segerson K, Miceli TJ (1998) Voluntary Environmental Agreements: Good or Bad News for Environmental Protection? *Journal of Environmental Economics and Management* 36:109-130
- Steffy L, Kilham S (2006) Effects of urbanization and land use on fish communities in Valley Creek watershed, Chester County, Pennsylvania. *Urban Ecosystems* 9:119-133
- U.S.Department of Agriculture (2011) Assessment of the effects of conservation practice on cultivated cropland in the Great Lakes Region. 172 pp
- U.S.Department of Agriculture. 2012. Electronic Field Office Technical Guide. Available: <http://www.nrcs.usda.gov/wps/portal/nrcs/main/national/technical/fotg>.

- U.S.Environmental Protection Agency (2000a) 2000 National Water Quality Inventory. EPA-841-R-02-001, United State Environmental Protection Agency, Office of Water, Washginton DC
- U.S.Environmental Protection Agency (2000b) Atlas of America's Polluted Waters. EPA 840-B00-002, Office of Water (4503F), United State Environmental Protection Agency, Washington, D.C.
- Valentin L, Bernardo DJ, Kastens TL (2004) Testing the Empirical Relationship between Best Management Practice Adoption and Farm Profitability. *Applied Economic Perspectives and Policy* 26:489-504
- Walter MT, Walter MF (1999) The New York City Watershed Agricultural Program(WAP): a model for comprehensive planning for water quality and agricultural economic viability. *Water Resources Impact* 1:5-8
- Walter MT, Walter MF, Brooks ES, Steenhuis TS (2000) Hydrologically sensitive areas: Variable source area hydrology implications for water quality risk assessment. *Journal of Soil and Water Conservation* 55:277
- Walter T, Dosskey M, Khanna M, Miller J, Tomer M, Wiens J (2007) The science of targeting within landscapes and watersheds to improve conservation effectiveness. In: Schnepf M, Cox C (eds), *Managing Agricultural Landscapes for Environmental Quality: Strengthening the Science Base*. Soil and Water Conservation Society, Ankeny, IA, USA, pp 63-89
- Wang L, Lyons J, Kanehl P (2002) Effects of watershed best management practices on habitat and fish in Wisconsin streams. *Journal of the American Water Resources Association* 38:663-680

- Wang L, Lyons J, Kanehl P, Bannerman R (2001) Impacts of urbanization on stream habitat and fish across multiple spatial scales. *Environmental Management* 28:255-266
- Waters TF (1995) Sediment in streams: sources, biological effects, and control. American Fisheries Society Monograph 7, Bethesda, Maryland, 251 pp
- Winsten JR, Hunter M (2011) Using pay-for-performance conservation to address the challenges of the next farm bill. *Journal of Soil and Water Conservation* 66:111A-117A
- Wood PJ, Armitage PD (1997) Biological effects of fine sediment in the lotic environment. *Environmental Management* 21:203-217

Table 4.1. Key variables, their source, and method of computation as used in each step of the decision support framework as presented in the Missouri River basin case study. Detailed methodology for each variable can be found in the citations provided.

Step in Decision Process	Key Variables	Source of Variable	Formula or Method used in Case Study
1	Reference Condition (RC)	Statistically calculated for each ecoregion from existing fish community sampling data (Fore Chap. 3)	RC = mean lithophil abundance of watersheds with ATI & NATI < 50th percentile
	Base Condition (BC)	Multiple regression model predicting lithophil abundance, assuming no CPs implemented (Fore Chap. 3)	BC = $f(\text{Physiographic variables} + \text{Human threats})$
	Conservation Condition (CC)	Multiple regression model predicting lithophil abundance, currently implemented CPs (Fore Chap. 3)	CC = $f(\text{Physiographic variables} + \text{Human threats} + \text{CPs})$
2	Agricultural Threat Index Scores (ATI)	Statistically calculated for each stream reach based on a relativized ranking of agricultural threats across each ecoregion (Fore Chap. 2)	$ATI_{i,j} = \left[\frac{Ts_{i,j} + \dots + Ts_n}{\max(Ts_{i,j} + \dots + Ts_n)} \right] \times 100$ <i>Ts</i> = standardized threat metric
	Non-Ag Threat Index Scores (NATI)	Statistically calculated for each stream reach based on a relativized ranking of non-agricultural threats across each ecoregion (Fore Chap. 2)	$NATI_{i,j} = \left[\frac{Ts_{i,j} + \dots + Ts_n}{\max(Ts_{i,j} + \dots + Ts_n)} \right] \times 100$ <i>Ts</i> = standardized threat metric

NRCS Primary
Management
Capacity
(PMC)

Calculated for each watershed based on
quartile scores ATI_Q and $NATI_Q$ (Fore Chap.
2)

$$PMC_{score} = \frac{ATI_Q}{NATI_Q}$$

$$PMC = PMC_{score} \geq 2$$

3

Total cost (TC)

Calculated using CP scenario costs and output
from multiple-regression models that predicted
needed CP scenario density. See Table 4.4

$$TC = \text{CP scenario density needed} \times \text{CP cost}$$

Cost/benefit
ratio (CB)

Calculated using total cost of conservation and
output from multiple-regression models that
were used to determine conservation need.

$$CB = TC \div \# \text{ of } 0.01 \text{ units of guild abundance increase}$$

Table 4.2. Key variables and their descriptions used in the multiple-regression model that predicted lithophil guild abundance. Human threat indices were used as inputs to the multiple-regression model and were used to calculate NRCS primary management capacity and the variables that compose each index are listed.

Key Variable	Description
Multiple-regression model to predict lithophil guild abundance	
Physiographic variables (proportion of watershed)	Soil texture classes, soil hydrologic classes, surficial geology, % rock fragment, depth to bedrock classes
Human threats (index scores 0 - 100)	Agricultural, urban, point-source pollution, infrastructure
NRCS CPs (proportion of watershed)	Reduce soil disturbance, reduce sedimentation, reduce sedimentation (m/km ²)
Human Threat Indices	
Agricultural	Row-crop, estimated grazing, channelized streams
Urban	Impervious surface, population density, population change
Point-source Pollution	Mines, CERCLIS ^a , TRI ^b , RCRA ^c , NPDES ^d , landfills
Infrastructural	Road crossings, rail crossings, dams
Non-agricultural	Impervious surface, population density, population change, mines, CERCLIS ^a , TRI ^b , RCRA ^c , NPDES ^d , landfills, road crossings, rail crossings, dams

^aCERCLIS = Comprehensive Environmental Response, Compensation, and Liability Information System sites

^bToxic Release Inventory sites

^cRCRA = Resource Conservation & Recovery Act sites

^dNPDES = National Pollutant Discharge Elimination System sites

Table 4.3. Conservation practices, their NRCS practice code, and their definitions that made up each conservation practice scenario used in the decision support framework for the Missouri River basin. The first scenario is made up of conservation practices designed 1) to reduce soil disturbance and prevent soil erosion, and the other scenario is made up of conservation practices designed 2) to reduce sedimentation by preventing eroded materials from entering stream channels.

Practice		
Code	Practice Name	Practice Definition
Practices to Reduce Soil Disturbance		
327	Conservation Cover	Establishing and maintaining permanent vegetative cover to protect soil and water resources.
329 (A, B, C)	Residue and Tillage Management, No-till, Strip Till, or Ridge Till	Managing the amount, orientation and distribution of crop and other plant residue on the soil surface year round while limiting soil-disturbing activities to only those necessary to place nutrients; condition residue and plant crops.
342	Critical Area Planting	Establishing permanent vegetation on sites that have or are expected to have high erosion rates; and on sites that have physical; chemical or biological conditions that prevent the establishment of vegetation with normal practices.
345	Mulch Till	Managing the amount, orientation, and distribution of crop and other plant residues on the soil surface year-round, while growing crops on pre-formed ridges alternated with furrows protected by crop residue.
472	Use Exclusion	The temporary or permanent exclusion of animals; people or vehicles from an area.
528(A)	Prescribed Grazing	Managing the controlled harvest of vegetation with grazing animals.
643	Restoration and Management of Rare & Declining Habitat	Restoring and managing rare and declining habitats and their associated wildlife species to conserve biodiversity.
645	Upland Wildlife	Provide and manage upland habitats and connectivity

Habitat
Management

within the landscape for wildlife.

Practices to Reduce Sedimentation

328	Conservation Crop Rotation	Growing crops in a recurring sequence on the same field.
330	Contour Farming	Tillage, planting, and other farming operations performed on or near the contour of the field slope.
344	Seasonal Residue Management	Managing the amount, orientation, and distribution of crop and other plant residues on the soil surface during a specified period of the year, while planting annual crops on a clean-tilled seedbed, or when growing biennial or perennial seed crops.
391	Riparian Forest Buffer	An area of predominantly trees and/or shrubs located adjacent to and up-gradient from watercourses or water bodies.
393	Filter Strip	A strip or area of herbaceous vegetation situated between cropland, grazing land, or disturbed land (including forestland) and environmentally sensitive areas.
412	Grassed Waterway	A natural or constructed channel that is shaped or graded to required dimensions and established with suitable vegetation.
484	Mulching	Applying plant residues, by-products or other suitable materials produced off site, to the land surface.

Table 4.4. Cost of individual conservation practices and conservation practice scenarios by ecoregion. The individual conservation practice costs are represented as the mean cost per square kilometer among the states of Nebraska, Missouri, Kansas, South Dakota, and North Dakota. Scenario costs were estimated by multiplying the “practice percentage by ecoregion” field with each practices’ mean cost and summing the respective practice costs. Practices in the reduce soil disturbance scenario are designed to prevent erosion and practices in the reduce sedimentation scenario prevent sediment from entering stream channels. The ecoregion abbreviations are HCD = Hot Continental Division and PD = Prairie Division.

Practice Code	Practice Name	Practice Percentage by Ecoregion		Practice Cost (\$USD)/km ²	Weighted Practice Cost by Ecoregion (\$USD)/ha	
		HCD	PD		HCD	PD
Reduce Soil Disturbance Scenario						
327	Conservation Cover	-	8	555,163	-	0*
329 (A, B, C)	Residue and Tillage Mgmt., No-till, Strip Till, or Ridge Till	7	43	4,576	320	1,967
342	Critical Area Planting	3	-	45,681	1,370	-
345	Mulch Till	4	6	2,447	97	146
472	Use Exclusion	7	13	6,869	480	893
528(A)	Prescribed Grazing	38	13	8,349	3,172	1,085
643	Restoration and Mgmt. of Rare & Declining Habitat	39	1	43,127	16,819	431
645	Upland Wildlife Habitat Mgmt.	-	14	39,935	-	5,590
Total Percent & Cost		98	98		22,262	10,115
Reduce Sedimentation Scenario						

328	Conservation Crop Rotation	51	62	10,326	5,266	6,402
330	Contour Farming	21	29	4,608	967	1,336
344	Seasonal Residue Mgmt.	20	6	6,202	1,240	372
391	Riparian Forest Buffer	2	-	213,391	4,267	-
393	Filter Strip	1	-	26,716	267	-
412	Grassed Waterway	4	-	352,060	14,082	-
484	Mulching	1	-	35,166	351	-
Total Percent & Scenario Cost		100	97		26,443	8,110

*Practice was excluded from cost estimate for scenario. The cost estimate was only from one state (SD) and the addition of the practice into the scenario would have increased the total scenario cost five times the reported value.

Table 4.5. Summary statistics of total cost estimates for conservation and the percentiles of cost-benefit ratio for the different conservation practice scenarios by ecoregion. The cost-benefit ratio values are expressed as the cost (\$USD) of increasing lithophil guild abundance by units of 0.01 and the percentiles were calculated within each ecoregion. The reduce disturbance and sedimentation scenario assumes equal proportions of both practice scenarios were implemented in a watershed and their effects to lithophil abundance were summed.

	Hot Continental Division			Prairie Division		
	Conservation Practice Scenario					
	Reduce Soil Disturbance	Reduce Sedimentation	Reduce Disturbance & Sedimentation	Reduce Soil Disturbance	Reduce Sedimentation	Reduce Disturbance & Sedimentation
Cost (\$USD)						
<i>n</i>	651	470	563	326	3,393	4,133
Mean	345,120	667,924	738,777	317,951	295,057	676,550
Std. Error	33,491	72,025	75,931	17,396	7,292	16,966
Minimum	51	58	107	3,027	823	1,850
Maximum	4.42×10 ⁶	7.40×10 ⁶	9.03×10 ⁶	1.48×10 ⁶	3.60×10 ⁶	10.45×10 ⁶
Cost-benefit Percentile (\$USD/lithophil guild abundance increase of 0.01)						
10	823	1,502	1,687	60,567	16,635	31,547
15	1,097	2,160	2,334	76,100	22,473	42,013
25	1,894	3,944	3,871	106,336	32,616	62,348
50	6,118	11,988	12,730	206,185	64,104	121,077
75	34,418	95,382	70,546	397,342	122,782	235,965

Table 4.6. Percentiles of cost-benefit ratio for each conservation practice scenario for the entire assessment region, irrespective of ecoregion. The cost-benefit ratio values are expressed as the cost (\$USD) of increasing lithophil guild abundance by 0.01 units and the percentiles were calculated within each ecoregion.

Cost-benefit percentiles (\$USD/lithophil guild abundance increase of 0.01)	Reduce Soil Disturbance	Reduce Sedimentation	Reduce Disturbance & Sedimentation
<i>n</i>	977	3,863	4,696
10	1,097	10,074	15,213
15	1,703	15,961	27,227
25	3,360	27,614	49,396
50	29,692	59,967	110,546
75	211,633	121,069	228,288

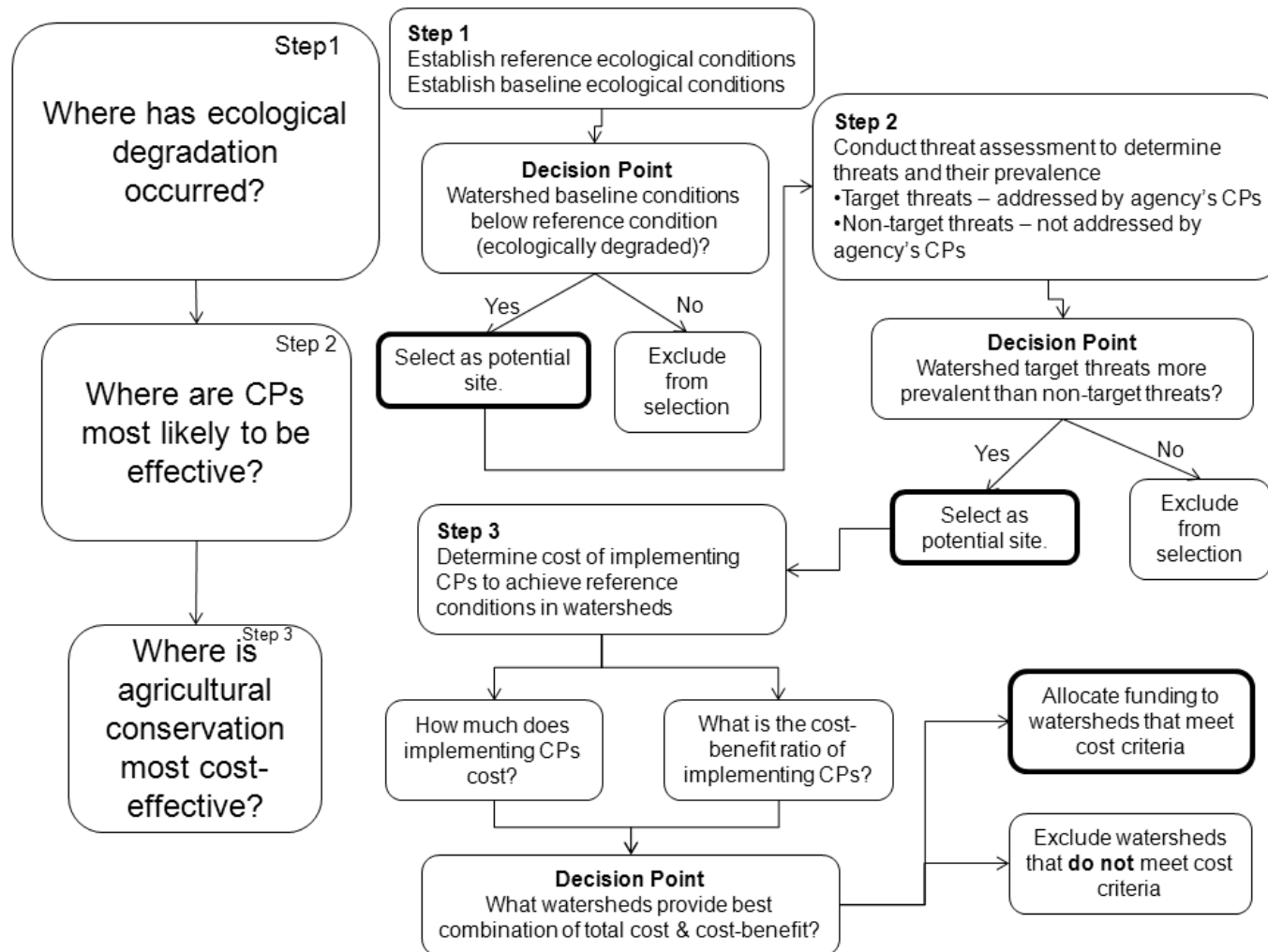

Figure 4.1. Flow diagram depicting the process of the decision support framework to prioritize and select watersheds for agricultural conservation. The leftmost diagram represents the three major components of the decision framework and the size of the boxes signifies the winnowing process of selecting watersheds. The remaining diagram represents the key components, major decision points, and outcome (boxes in bold) for each step of the framework. See Fore (chap. 3) for detailed methodology on Step 1 and Fore (Chap. 2) for details on Step 2.

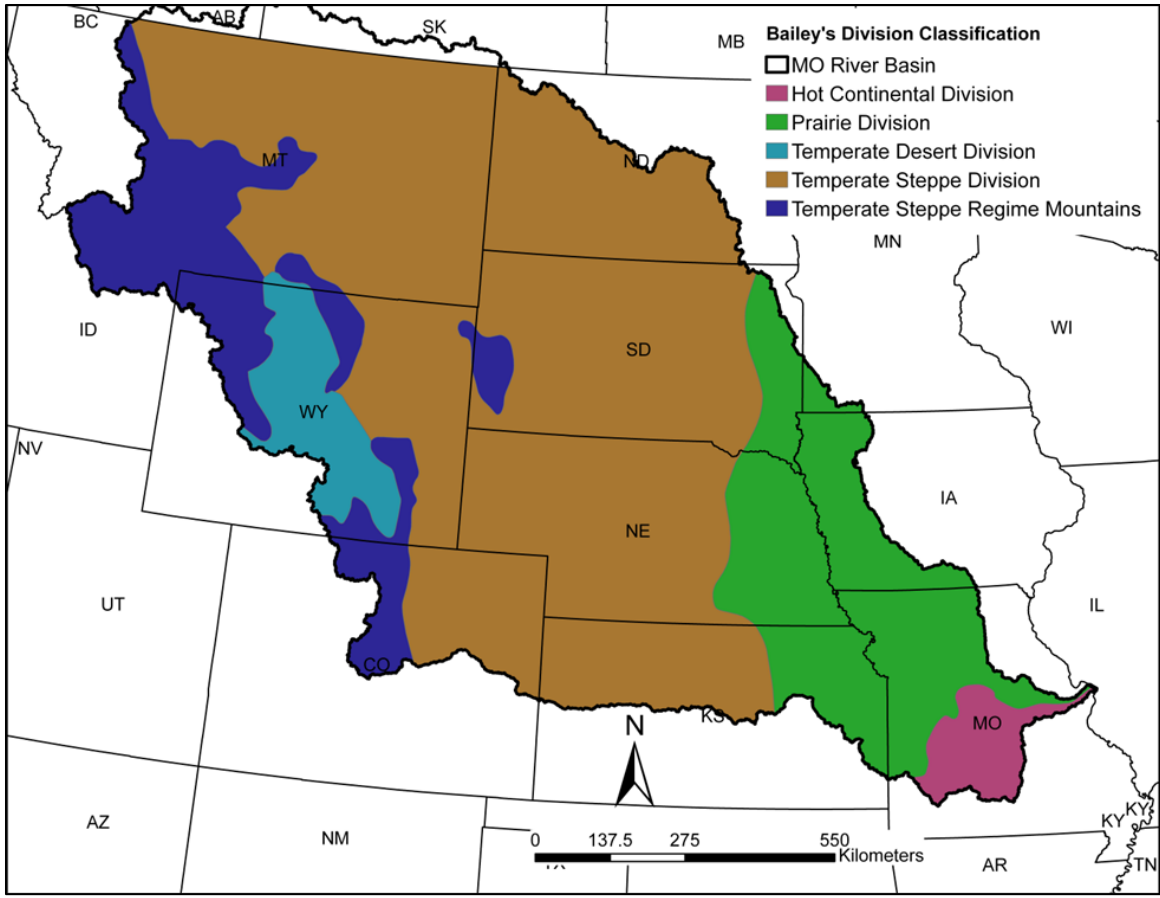

Figure 4.2. Map of Missouri River basin showing Bailey's Divisions that were used as an ecoregion classification. The case study was conducted in the Hot Continental Division and the Prairie Division.

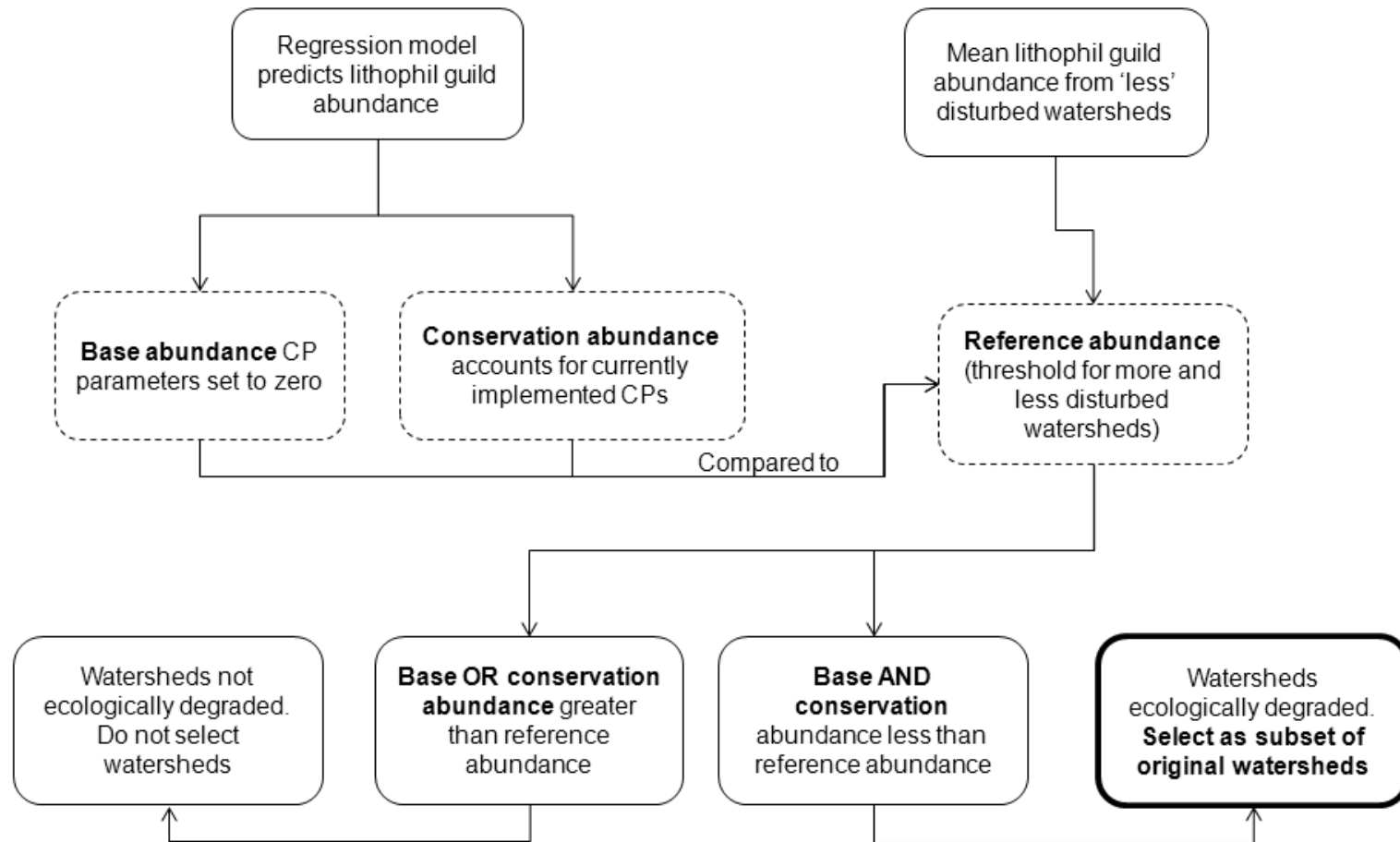

Figure 4.3. Flow diagram depicting the process of determining watersheds that were ecologically degraded (step 1 of Fig. 4.1). Dashed boxes represent key variables used to classify watersheds as ecologically degraded. The bold box represents the major output from this step. Refer to Table 4.1 for descriptions of the key variables and multiple-regression model used in this process. Refer to Table 4.2 for description of key inputs to the multiple-regression model used in this process.

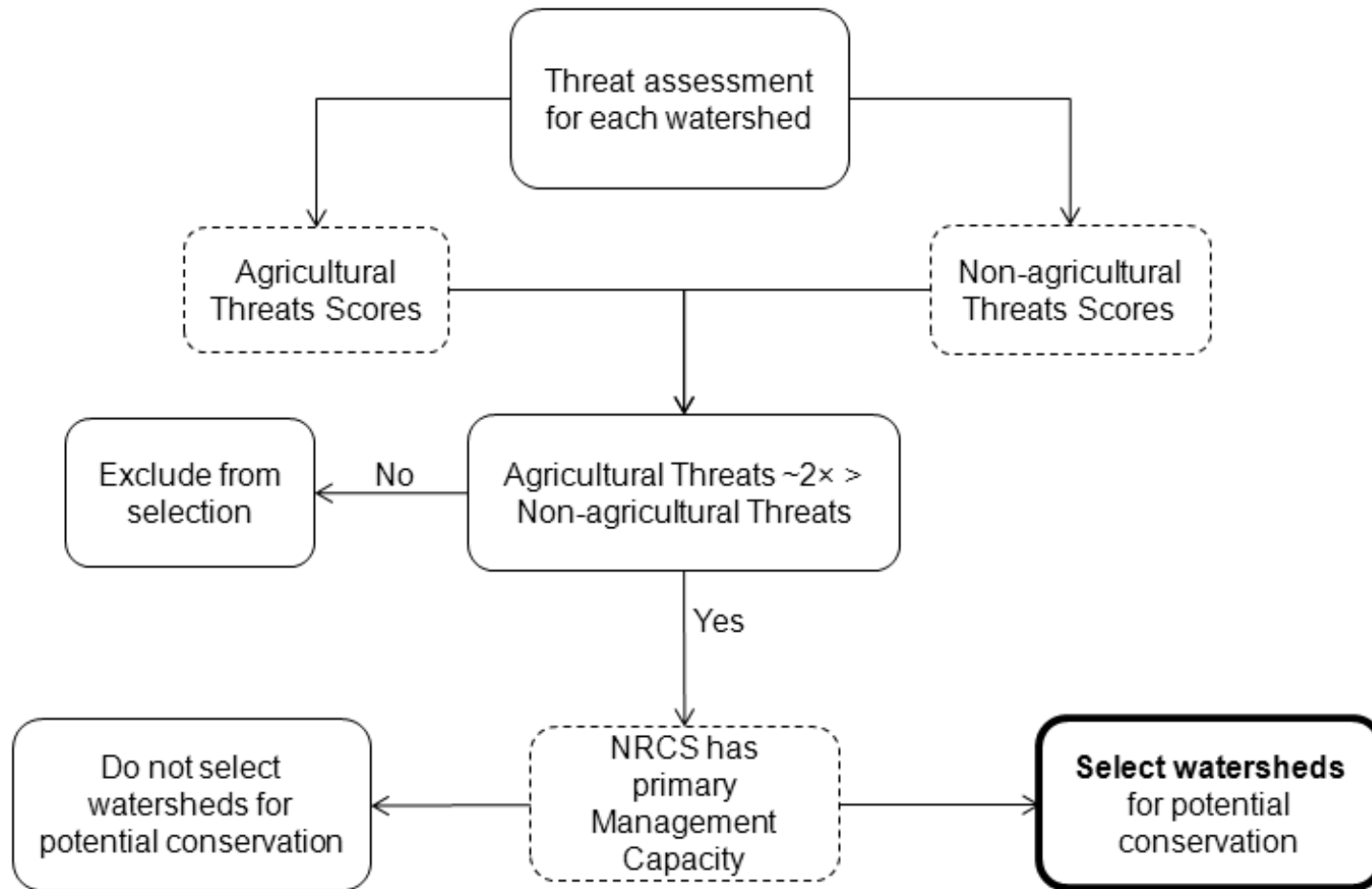

Figure 4.4. Flow diagram depicting the process of determining watersheds where NRCS had primary management capacity (step 2 of Fig. 4.1). Dashed boxes represent key variables used to determine NRCS primary management capacity. The bold box represents the major output from this step. Refer to Table 4.1 for descriptions of the threat indices used in this process. Refer to Table 4.2 for description of key inputs to the threat indices used in this process.

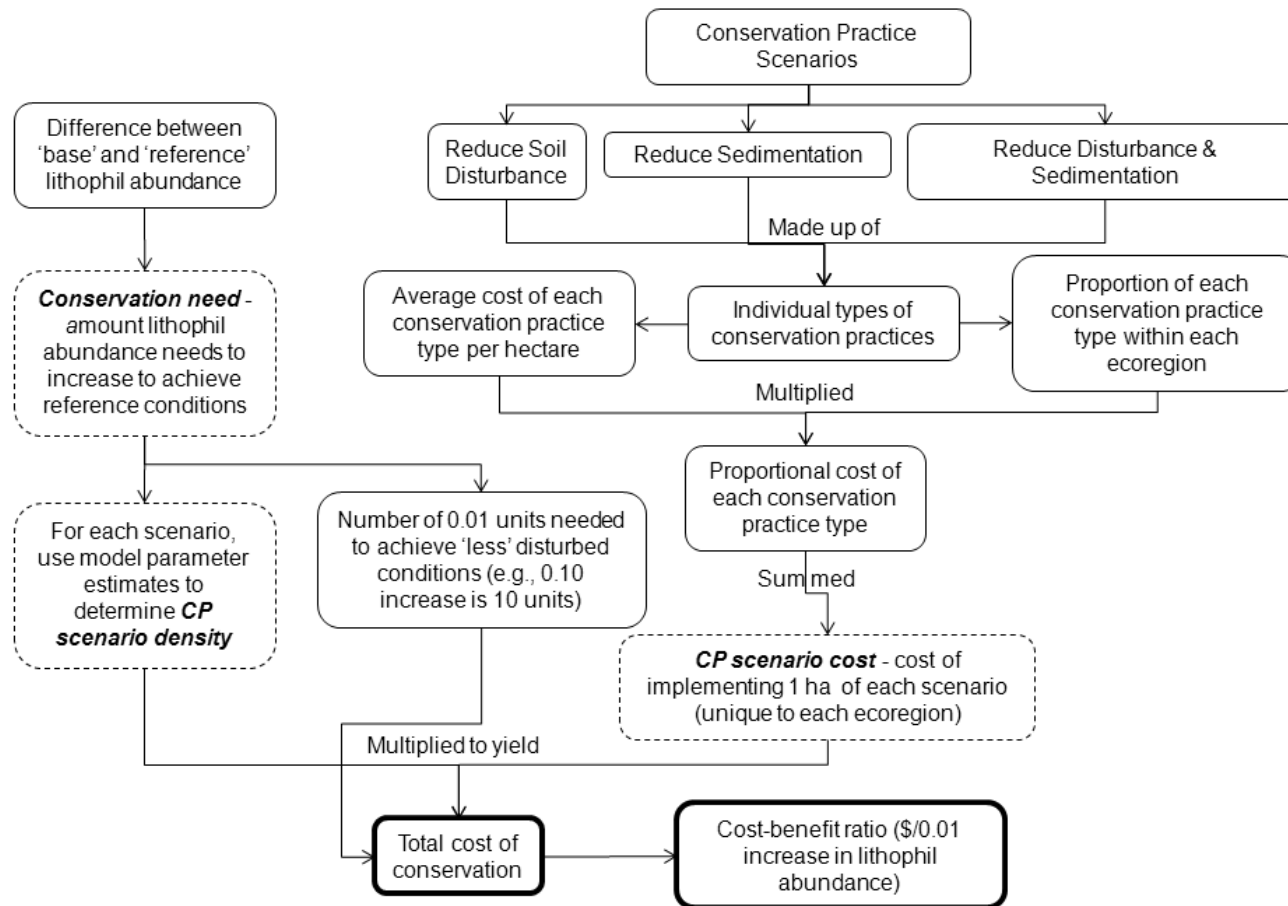

Figure 4.5. Flow diagram depicting the process of determining total conservation cost and cost-benefit ratio for each watershed in the study area (step 3 of Fig. 4.1). Dashed boxes represent the three key variables used to estimate total conservation cost for each watershed. The bold box represents the major outputs from this step. Refer to Table 4.1 for descriptions of the outputs from this process.

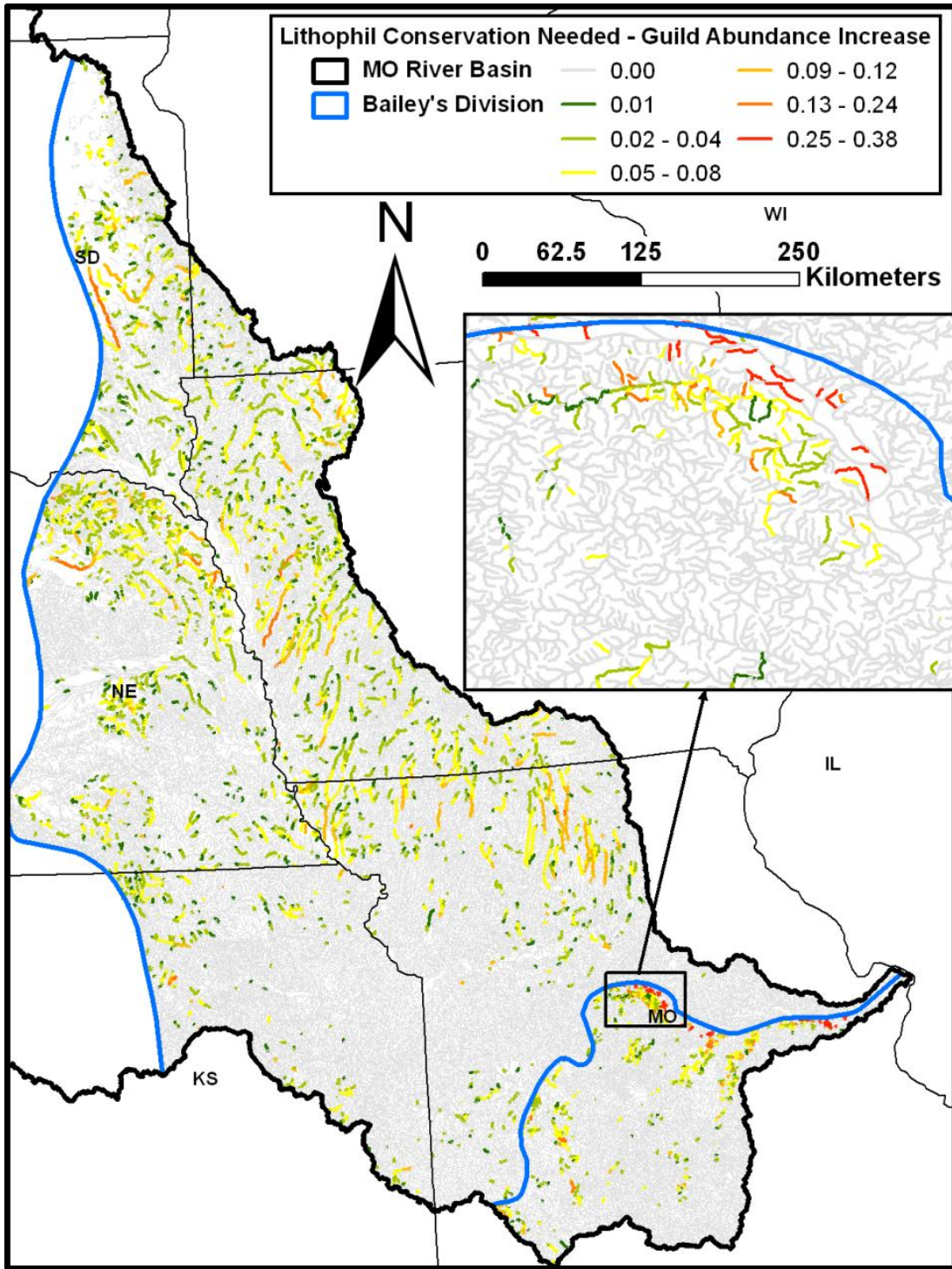

Figure 4.6. Map of predicted increase in lithophil abundance needed to shift watershed (as represented by stream segments) condition from 'more' disturbed to reference condition for all stream segments <500 link magnitude in Hot Continental and Prairie Divisions of the Missouri River basin. The abundance increase was estimated from models developed by Fore (Chap. 3).

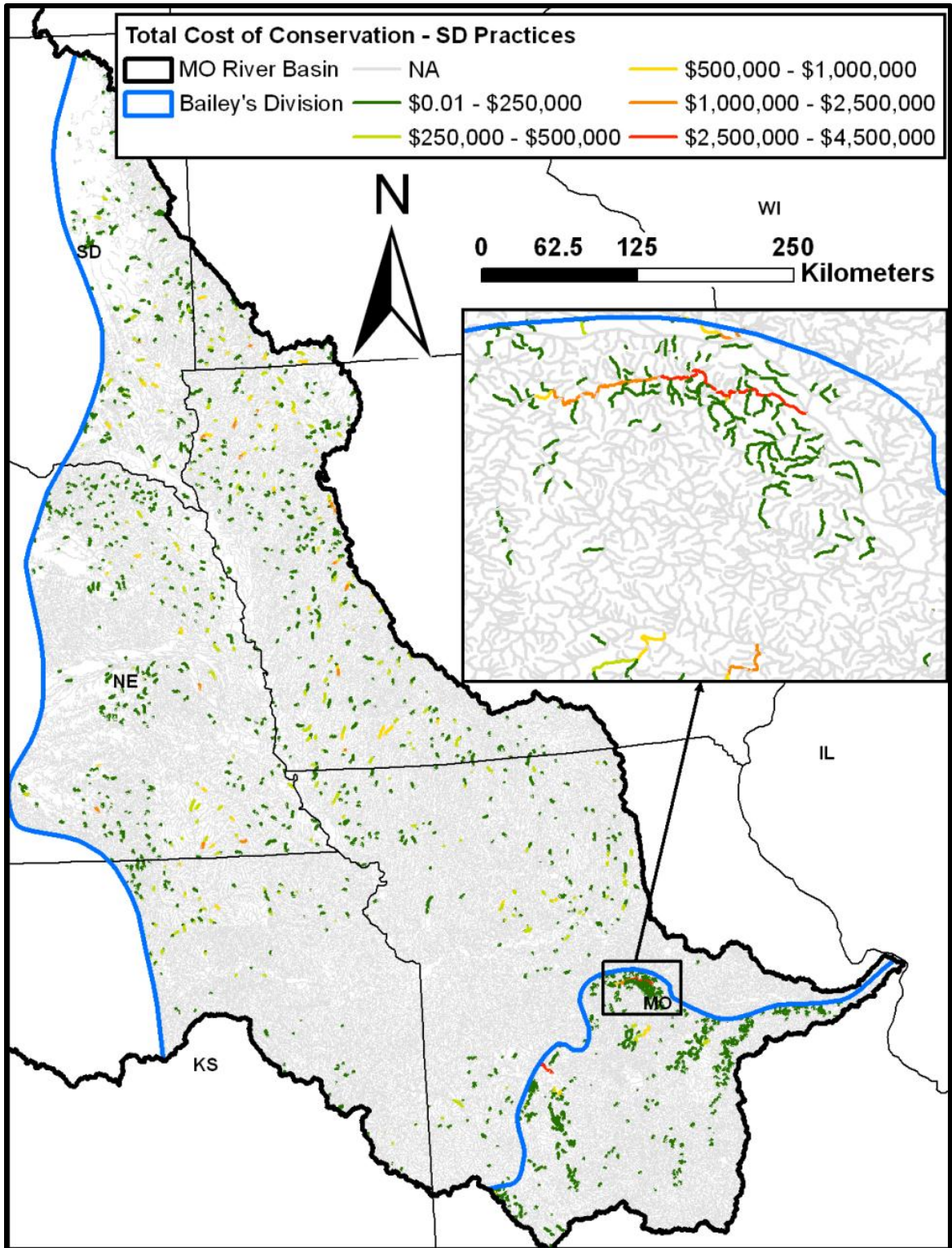

Figure 4.7. Map depicting total watershed conservation cost of improving fish assemblage condition from more disturbed to reference condition in stream segments in Hot Continental and Prairie Divisions of the Missouri River basin <500 link magnitude using the reduce soil disturbance conservation practice scenario.

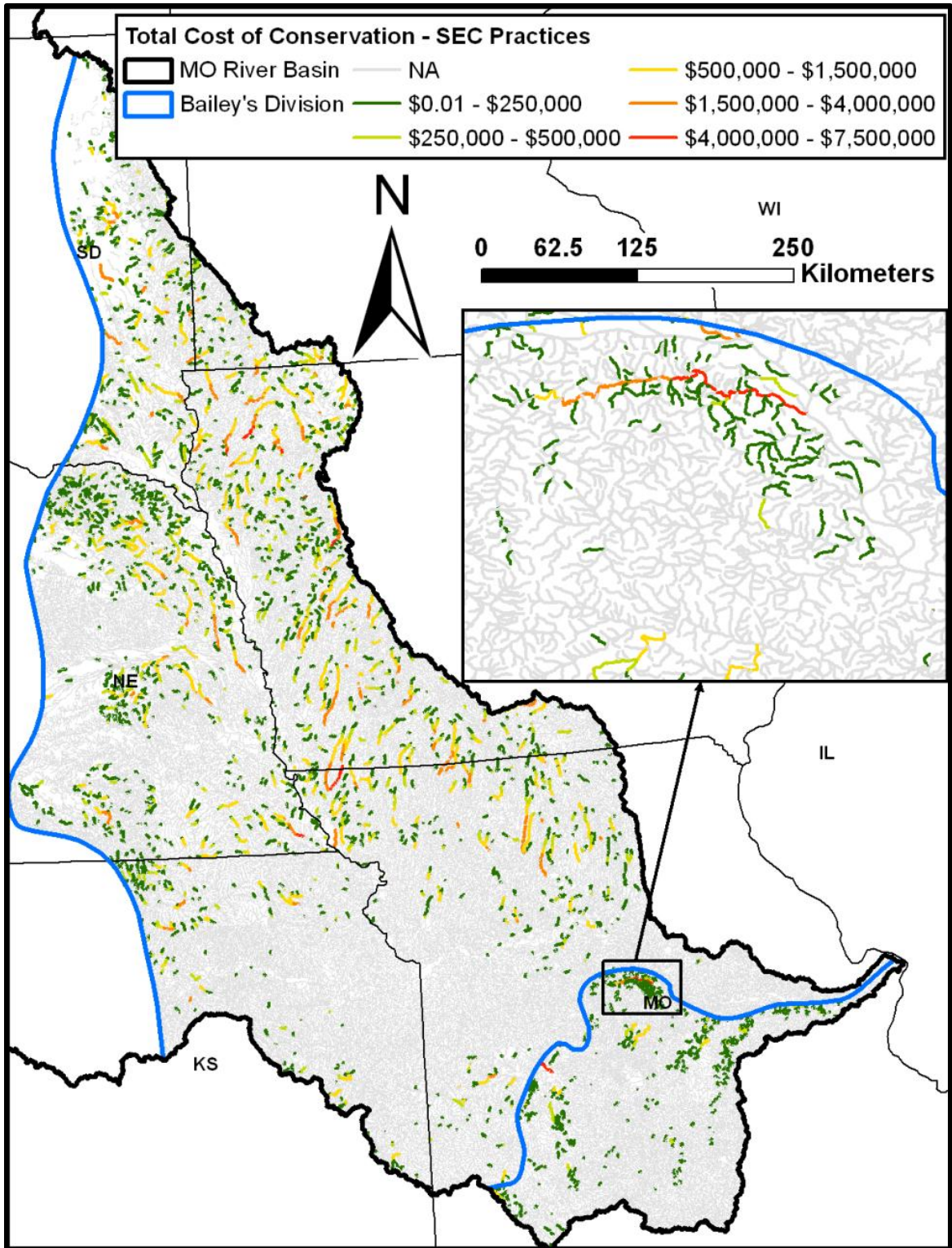

Figure 4.8. Map depicting total watershed conservation cost of improving fish assemblage condition from more disturbed to reference condition in stream segments in Hot Continental and Prairie Divisions of the Missouri River basin <500 link magnitude using the reduce sedimentation conservation practice scenario.

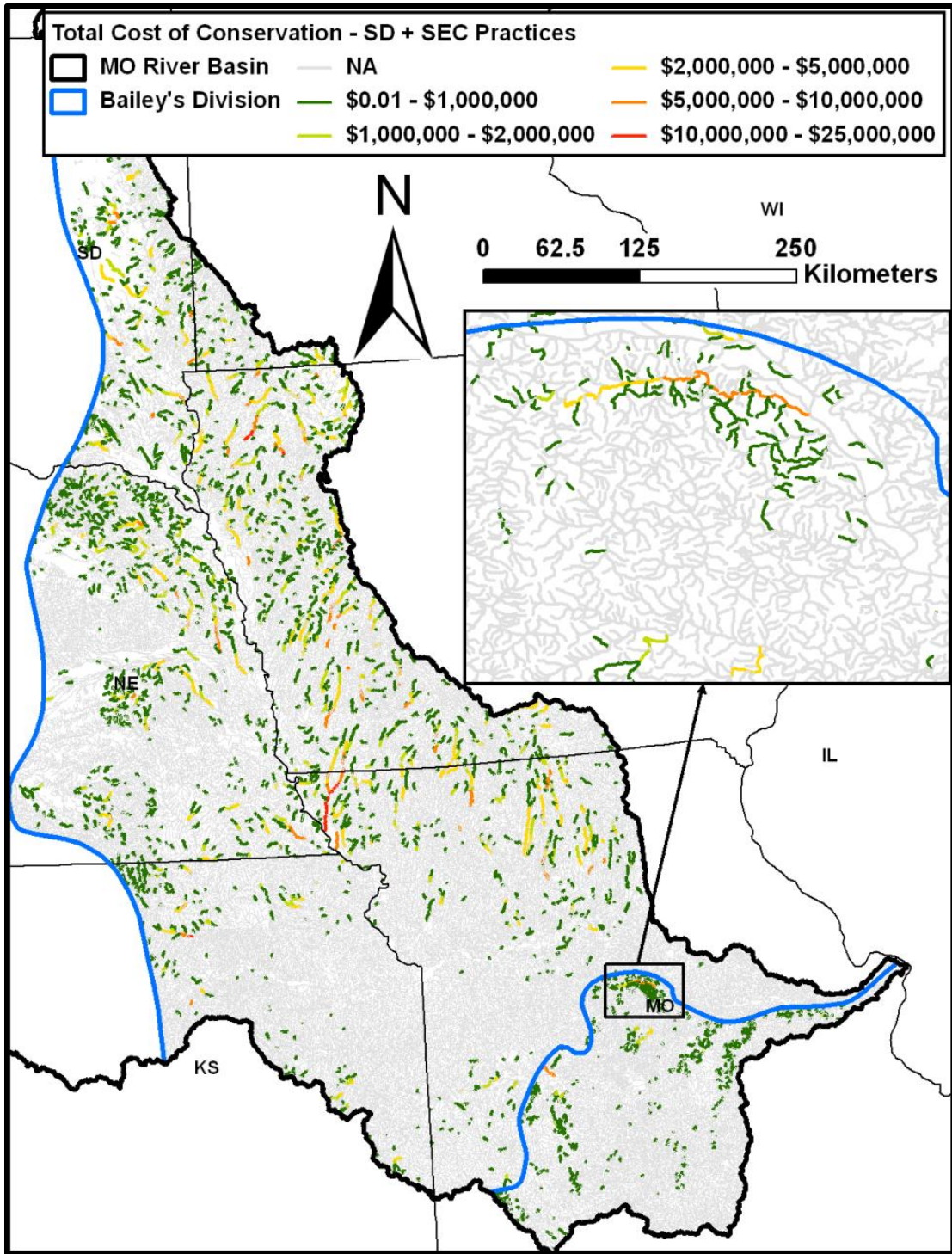

Figure 4.9. Map depicting total watershed conservation cost of improving fish assemblage condition from more disturbed to reference condition in stream segments in Hot Continental and Prairie Divisions of the Missouri River basin <500 link magnitude using the reduce disturbance and sedimentation conservation practice scenario.

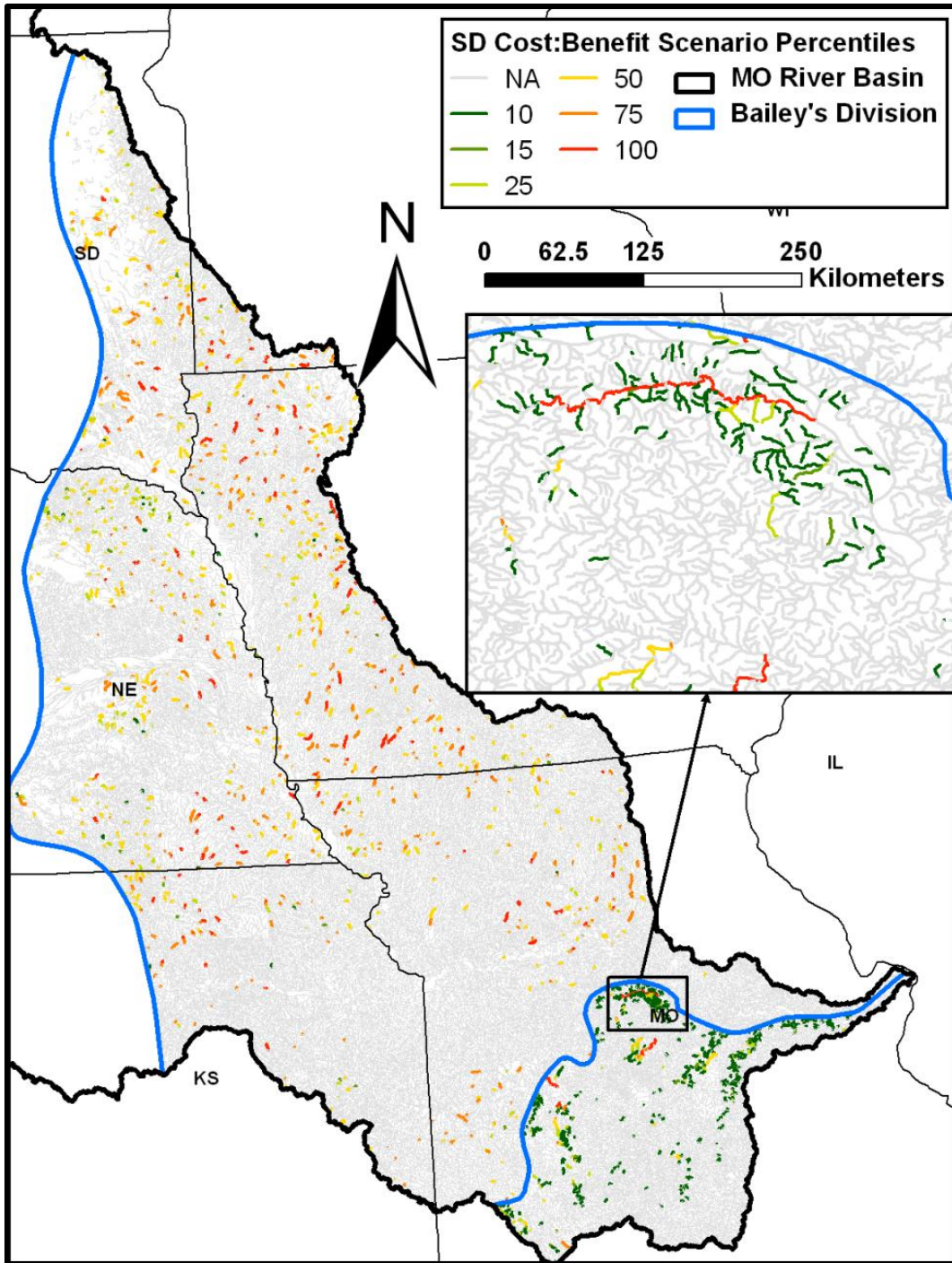

Figure 4.10. Map depicting watershed percentiles of the cost-benefit ratio in stream segments in Hot Continental and Prairie Divisions of the Missouri River basin <500 link magnitude for the reduce soil disturbance scenario. The percentiles were calculated across both the Hot Continental and Prairie Division. Refer Table 4.4 for the percentile values.

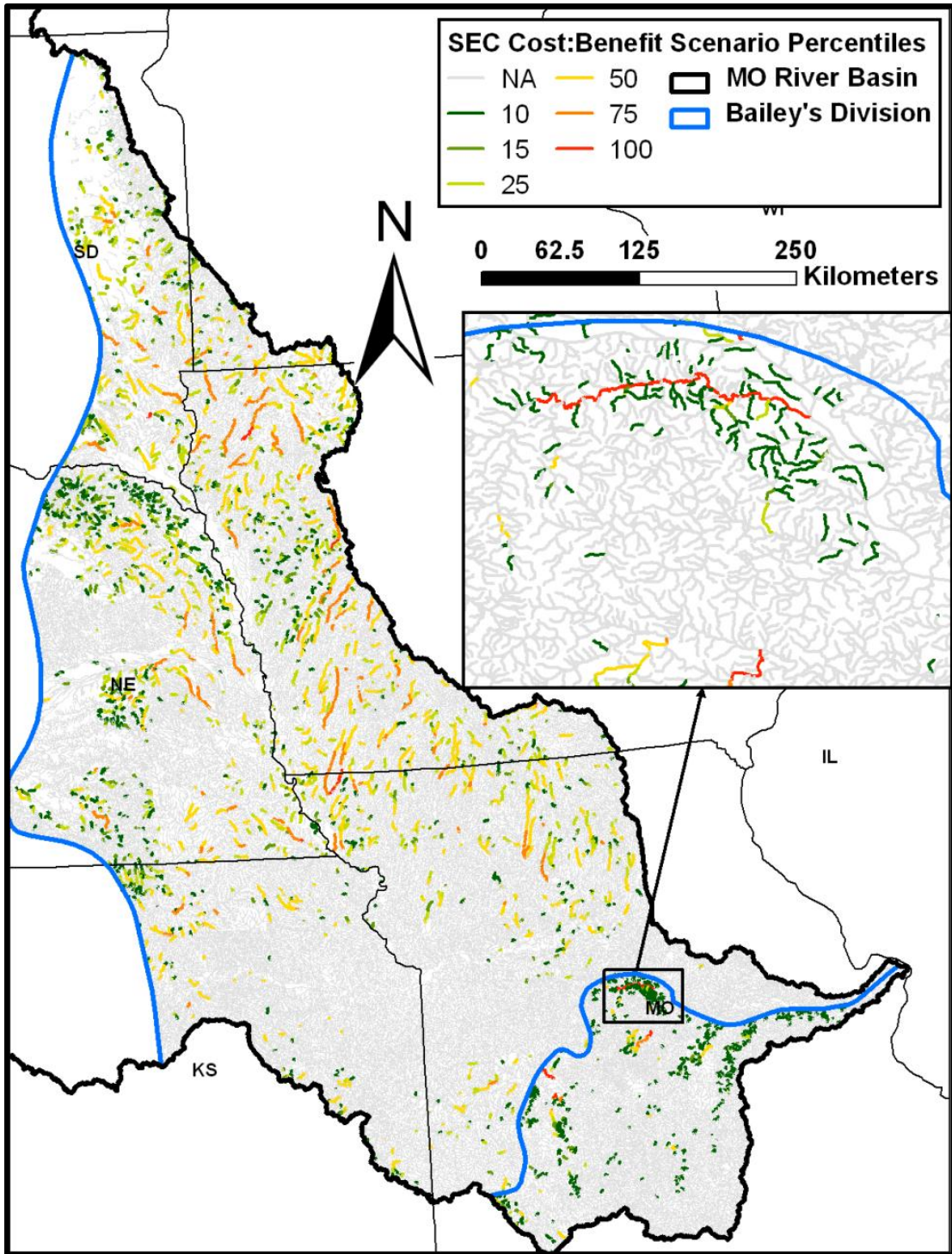

Figure 4.11. Map depicting watershed percentiles in stream segments in Hot Continental and Prairie Divisions of the Missouri River basin <500 link magnitude of the cost-benefit ratio for the reduce sedimentation scenario. The percentiles were calculated across both the Hot Continental and Prairie Division. Refer to Table 4.4 for the percentile values.

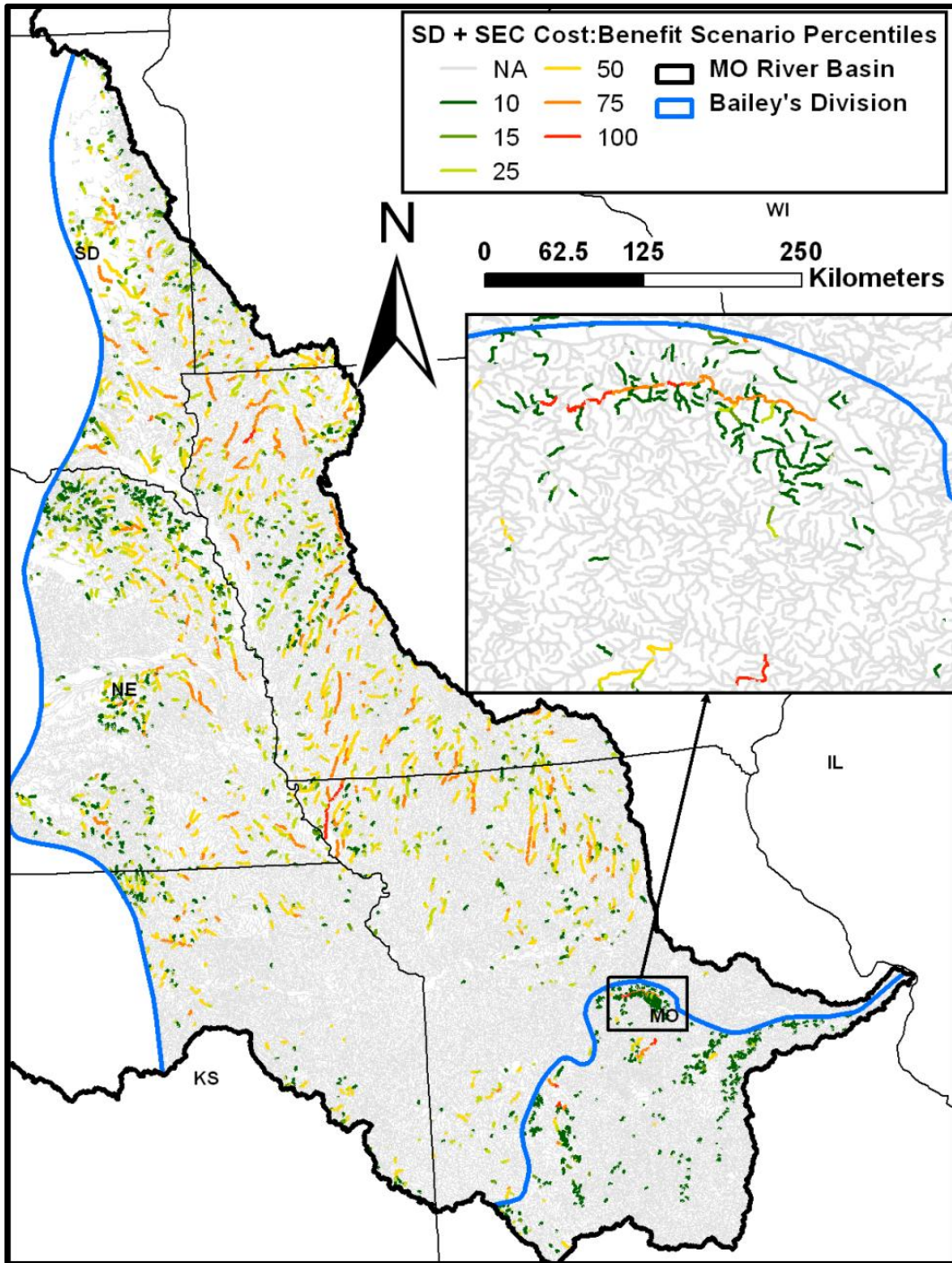

Figure 4.12. Map depicting watershed percentiles of the cost-benefit ratio in stream segments in Hot Continental and Prairie Divisions of the Missouri River basin <500 link magnitude for the reduce disturbance and sedimentation scenario. The percentiles were calculated across both the Hot Continental and Prairie Division. Refer to Table 4.4 for the percentile values.

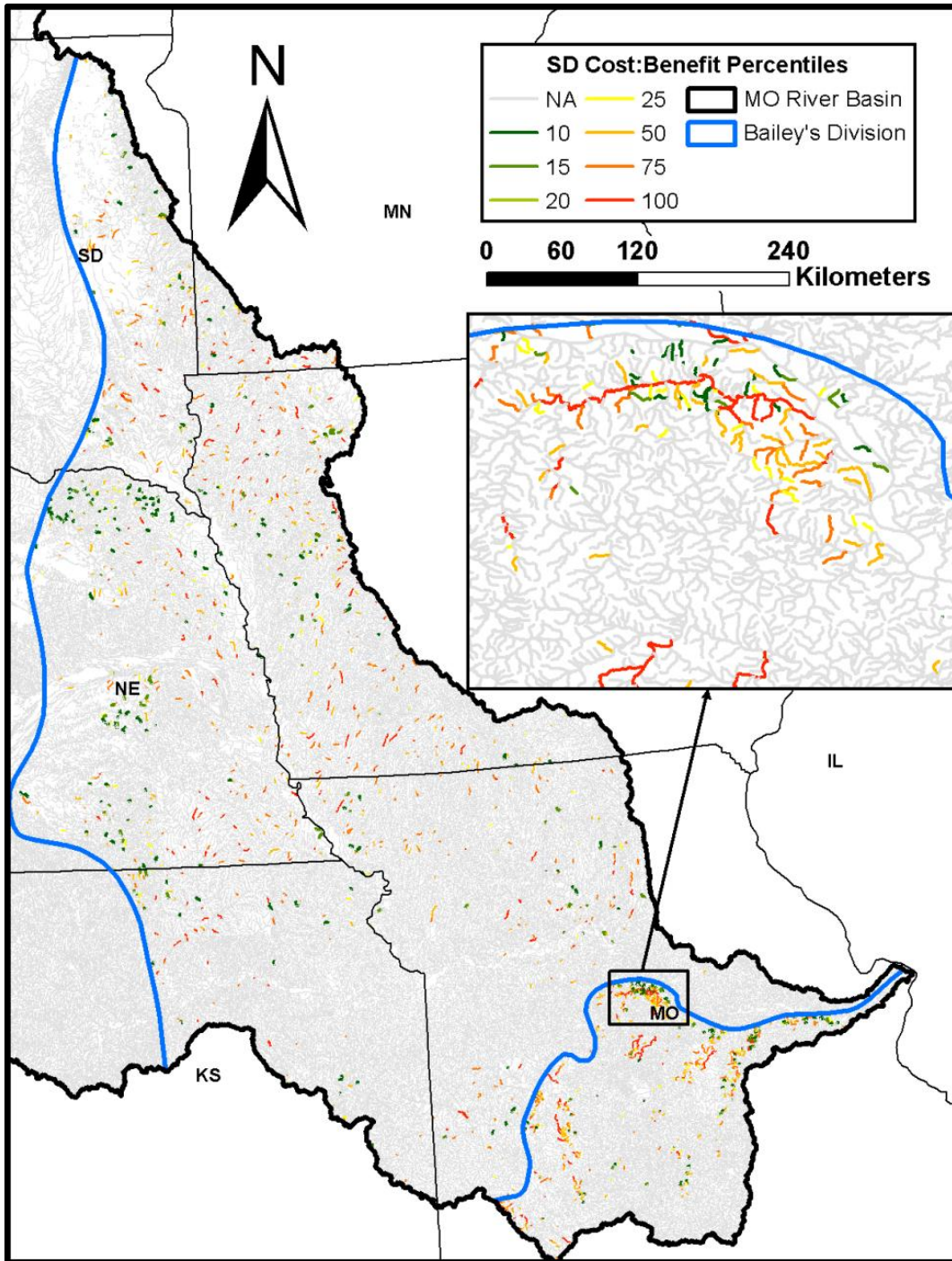

Figure 4.13. Map depicting watershed percentiles of the cost-benefit ratio in stream segments in Hot Continental and Prairie Divisions of the Missouri River basin <500 link magnitude for the reduce soil disturbance scenario. The percentiles were calculated separately for the Hot Continental Division and Prairie Division. Refer to Table 4.3 for the percentile values.

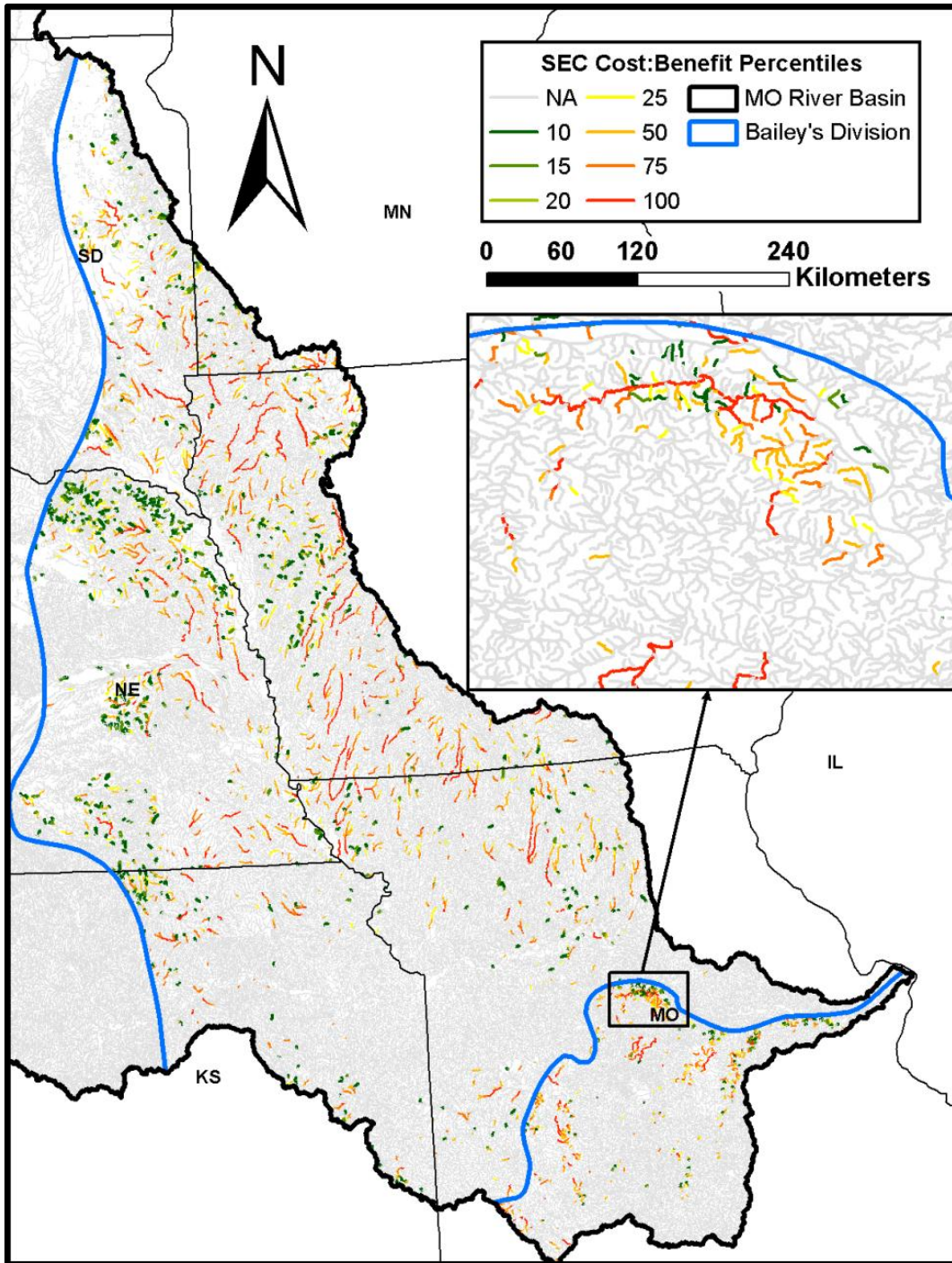

Figure 4.14. Map depicting watershed percentiles of the cost-benefit ratio in stream segments in Hot Continental and Prairie Divisions of the Missouri River basin <500 link magnitude for the reduce sedimentation scenario. The percentiles were calculated separately for the Hot Continental Division and Prairie Division. Refer to Table 4.3 for the percentile values.

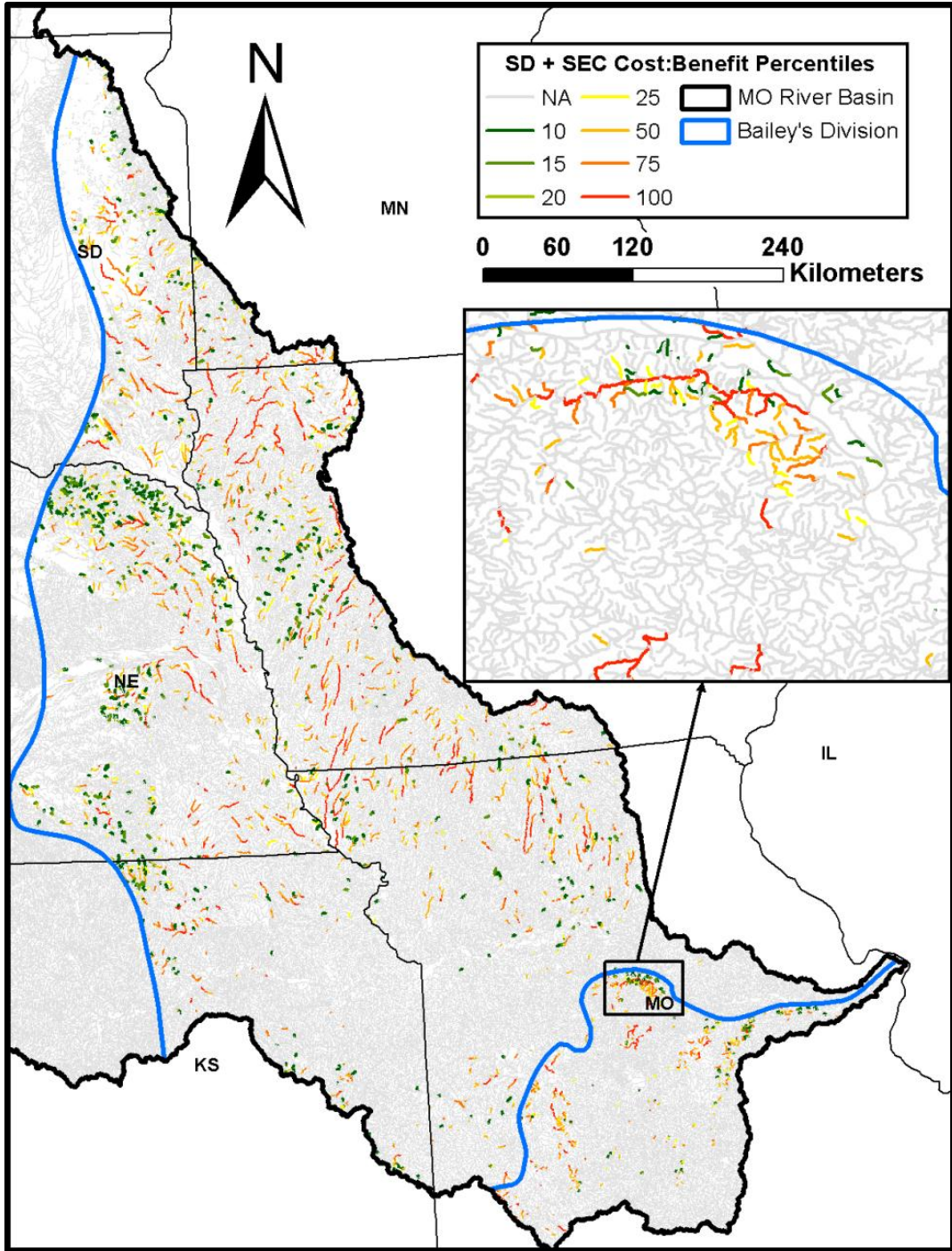

Figure 4.15. Map depicting watershed percentiles of the cost-benefit ratio in stream segments in Hot Continental and Prairie Divisions of the Missouri River basin <500 link magnitude for the reduce disturbance and sedimentation scenario. The percentiles were calculated separately for the Hot Continental Division and Prairie Division. Refer to Table 4.3 for the percentile values.

VITA

Jeffrey Fore was born on December 4, 1982 in Ponca City, OK. He obtained a B.S. in Fisheries and Wildlife Ecology from Oklahoma State University in 2006, a M.S. in Biology with an emphasis in stream ecology from Eastern Illinois University, and Ph.D. in Fisheries and Wildlife Sciences from the University of Missouri in 2012. He worked for the Oklahoma Cooperative Fish and Wildlife Research Unit and the Oklahoma Department of Wildlife Conservation during his undergraduate program. Jeff has been an active member of the American Fisheries Society throughout his career. He has served as Vice-president for the Oklahoma State University Subunit, the Founding President of the Eastern Illinois University Subunit, a member of the Continuing Education Committee, and as President of the Student Subsection of the Education Section.