

AGRICULTURAL GUIDE

Published by the University of Missouri-Columbia Extension Division

APR 05 1990
Horses-Breeding

Horse Breeding Arithmetic:

$$2 + 2 = 1$$

Wayne E. Loch and John W. Massey,
Department of Animal Science, College of Agriculture

On the average, two mares taken to the stallion for one service each and returned home for the remainder of the season will give birth to one foal—if you are lucky. The national average foal rate for mates bred is approximately 50 percent.

Under carefully controlled conditions, Andrews and McKenzie were able to get 69 percent of 110 mares settled by 2.3 stallion services and 4.7 artificial inseminations. The pasture-mated band of mares of the University of Missouri produced an 85 percent live foal rate over a 10-year period.

Scientific knowledge combined with experience will help make results of breeding practices more positive and predictable.

Role of the Mare in Reproduction

The mare's role in reproduction is to supply an internal and external environment for the new life, in addition to supplying half of its genetic material. Because of this two-fold role, complex hormonal actions and interactions require near-perfect cooperation from other body systems. When adverse conditions affect other systems, the reproductive mechanism may also be affected and may not function properly until the related condition is corrected. Even under conditions of apparent good health and care, wide variations in reproductive behavior between mares is the rule rather than the exception.

The Andrews-McKenzie research in two seasons with 35 light mares (grade Thoroughbreds) showed the following variations:

	Range	Average
	Days	Days
Duration of estrus (heat)	1-37	5.3
Appearance of foal heat*	2-30	11.4
Length of cycle	13-37	22.0
Length of interestrual period	5-33	16.0

*33 mares observed

In addition about 15 percent of the mares showed "split estrus," characterized by an initial heat period of one day or more followed by one or two days of a non-receptive period, then a subsequent return to heat for one or more days, at which time ovulation occurred.

"Silent heat" was identified in about 5 percent of the mares that were non-receptive to the stallion as determined by regular teasing.

In Tennessee tests reported by Perry, duration of heat from three to eight days was considered normal, with widest variations observed during winter months. Improved nutrition, prolonged illumination, and milder weather associated with the spring season appeared to increase reproductive capacity.

The practices of a single teasing 16 days after the last day of heat or 18 days after service were considered unsatisfactory in obtaining high settling percentages because of irregularity of duration of heat and length between cycles. A short heat period tends to be followed by a long rest period, and vice versa.

These observations emphasize to the practical horseman the importance of regular teasing and need for professional veterinary services for those mares that are problem breeders.

Physiology of the Mare

Reproductive organs of the mare are shown in Fig. 1.

The ovaries produce eggs that unite with the sperm to start the new individual. They also secrete the hormone, estrogen, which induces heat and produces other hormones that condition the reproductive tract for implantation and maintenance of the foetus.

The Fallopian tubes or oviducts are the customary site of fertilization of the ovum (egg) by the sperm and serve as a connecting link between the ovary and uterus.

The uterus consists of a body, cervix, and two horns, one of which receives the fertilized ovum for development.

The vagina receives the sperm during mating and functions as a passageway during parturition.

The practice by some breeders of "opening the mare," i.e., inserting the hand in the vagina and fingers in the cervix, is

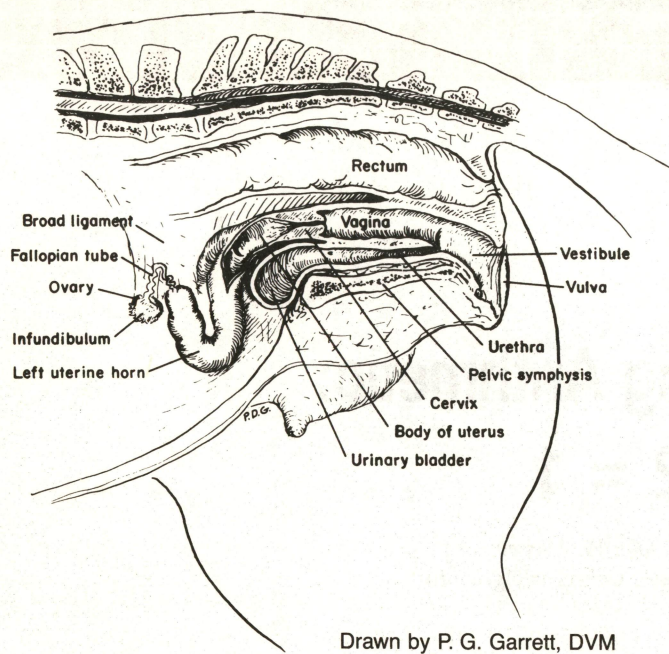

Drawn by P. G. Garrett, DVM

Figure 1. Reproductive organs of the mare.

indeed a dubious one. It serves no useful purpose and may induce temporary or permanent infection.

Plan for a Healthy Reproductive System

Maintaining health of the reproductive system is one goal of the breeder. Mares in poor condition seldom breed regularly. Adequate energy, phosphorus, and vitamin A are necessary. All of these are supplied in abundance in good pastures. If pastures are not available, feed according to UMC Guide 2807, "Feeding Horses."

Exercise may not be essential for regular breeding, but it does improve muscle tone of confined horses and tends to prevent overfatness.

A number of diseases affect the reproductive tract. Large breeding establishments usually require a health certificate from a veterinarian before breeding an outside mare.

Infection is quite common, especially with older mares. It may be detected by a qualified veterinarian on physical examination or by use of cultures. Some infections can be eliminated by appropriate treatment before breeding time.

Mares that have difficulty at parturition, retain the placenta, or show abnormal discharges should not be bred until the condition is corrected.

Foal heat is the first estrus after foaling and usually occurs 7-9 days after foaling. Breeding at foal heat is not recommended if there are any abnormalities or difficulties encountered at foaling. The reproductive tract has often not had time to return to normal, opportunity for infection is increased, and settling percentage is lowered. Andrews and McKenzie noted more than a 50 percent decrease in conception rate with mares bred at foal heat as compared to those bred at the second or later heat periods after foaling.

Taking Advantage of a Healthy Reproductive System

Mares should be at least three years old and in good condition at time of breeding. Ideally, they are bred the day the egg is released from the ovary. Knowing the day of release is a problem. We have already seen that heat may be variable in length, may come as a "split" cycle, or may be "silent."

Ovulation usually occurs about 24-48 hours before cessation of visible signs of heat. Since neither the egg nor spermatozoa live long individually at body temperature, time of breeding relative to egg release is critical. There is little wonder that low settling percentages result from the practice of "noticing signs of heat," taking the mare to the stallion, and returning her to pasture for the rest of the season.

Experienced veterinarians can predict date of ovulation quite accurately by daily palpation of the ovaries or ultrasound exam, and breeding can be synchronized with release of the egg.

According to Perry, ovulation can be effectively induced in some mares by intravenous injections of 1,000 to 2,000 international units of human gonadotropic hormone (HCG) administered after the mare has come in heat. Ovulation occurs 24 to 48 hours later.

Hormone treatment should be supervised by a competent veterinarian and should be used only when other methods fail.

Serious horse breeding involves breeding the mare daily or at least every other day until heat ceases, followed by regular and frequent teasing for at least two heat periods (45 days). Boarding the mare at the farm of the stallion owner or pasture mating is preferred.

Maiden mares should be initiated to the teasing process carefully or anxiety may mask signs of heat.

Mares with "split" cycles can be settled easily by the procedure outlined above; whereas, those with "silent" estrus must be identified by physical examination and bred by artificial insemination. In such cases, settling percentages may be quite satisfactory.

Old mares and those that are diseased require special diagnosis and treatment. Sometimes they can be restored to normal or partial fertility. Obviously, the expense incurred dictates restoration only of those of greatest value.

Role of the Stallion in Reproduction

The stallion must deliver healthy spermatozoa (which contain his genetic contribution) into the vagina of the mare at time of service. He should have enough libido (sex drive) to tease and service frequently and be able to sustain production of healthy spermatozoa throughout a concentrated breeding season.

Physiology of the Stallion

Reproductive organs of the stallion are shown in Fig. 2.

The male reproductive system consists of two testes, three accessory sex glands, and a series of tubules through which spermatozoa are transported to the female reproductive tract.

Spermatozoa are produced in small coiled seminiferous tubules in the testes that can be extended 400-500 feet in length. Since these developing cells cannot live at body temperature, heat regulation of the testes is critical. Scrotal muscles contract and expand as temperatures change in the normal process of temperature regulation. "Ridgling" or cryptorchid horses are sterile in the testis maintained in the body cavity, but are fertile in the suspended testis. Since this

condition is hereditary, it should not be propagated, as castration of a cryptorchid horse is usually a serious operation.

The accessory sex glands are the seminal vesicles, prostate, and bulbourethral gland. These furnish alkaline fluid secre-

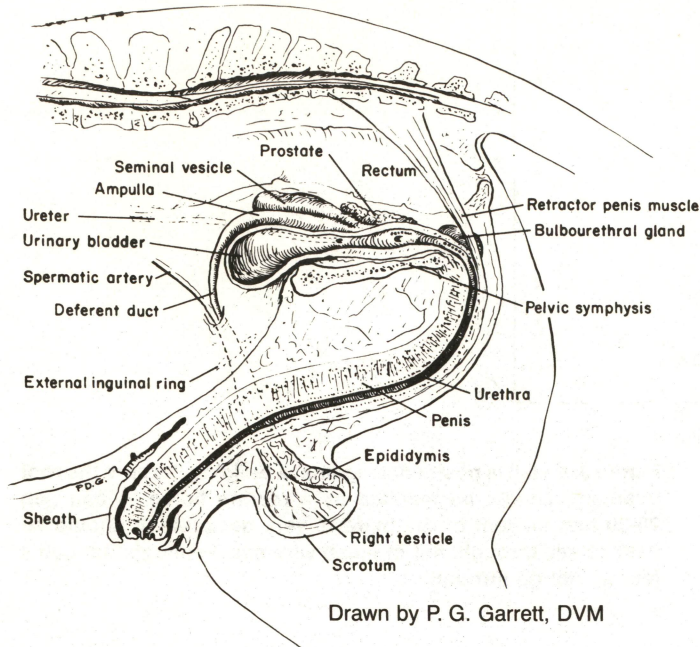

Figure 2. Reproductive organs of the stallion.

tions to transport and neutralize the uretha in which spermatozoa are transported from the epididymis through the urethra, which terminates at the end of the male genitalia glans penis.

Quantitative Data on Semen and Spermatozoa

Animal	Volume per Ejaculate in <i>MI</i>	Sperm per Cubic Millimeter	Total Sperm in Ejaculate
Stallion	25-150	60,000	6,000,000,000

The sperm life in the mare's tract is from 24 to 48 hours. Only in highly irregular or exceptional cases does it exceed this time span. Sperm has been found in the Fallopian tube 15 to 18 minutes after coitus but the normal time to travel from site of deposit to the Fallopian tube is 5 to 8 hours. The average egg life is also only 5 to 8 hours.

Because of a long estrous cycle and short life span of the spermatozoa and egg, it is not uncommon to have a lower than 50 percent conception rate.

Care and Use of a Healthy Stallion

1. Breeding Rates

Yearlings should not be depended upon for breeding. Two-year-olds may settle 10 mares, three-year-olds 30, and mature stallions 50 mares when handmated. About half of this number can be pasture-mated. A short breeding season will reduce the number, and sexual individuality of the stallion will greatly affect his siring ability.

2. Feeding and Management

The breeding stallion should be fed like a horse at hard work. An estimate is 1½ lbs. of grain and 1 lb. of hay per 100 lbs. body weight. (See UMC Guide 2807 for details.) If he is worked under saddle, more feed will be required. Because of diverted interests, a ration high in palatability may be necessary for some stallions to get adequate intake.

Regular exercise usually results in increased vigor (libido) and fertility.

Regular grazing of good grass, even for short periods of time, is recommended.

For safety's sake, fences should be strong and tall when stallions are grazed loose; and mares should not be in adjoining pastures unless extremely tall fences are used.

3. Methods of Mating

Pasture mating, hand-mating and artificial insemination are the three methods used, with variations of each. Breed registry regulations vary regarding the use of artificial insemination.

Pasture-mating reduces labor, affords convenience to the owner, "catches" shy breeding mares, and creates an opportunity for a high settling percentage. It has the disadvantage of reducing the number of mares a stallion can serve, and obscures breeding dates. Some risk to the stallion is incurred.

Stallions should be hand-mated a few times as two-year-olds, then turned in a large pasture with a few older mares when they are to be used in a pasture breeding program. Even so, they are likely to carry some scars from their experience. For this reason, pasture-mating is seldom used with breeds whose owners discriminate against blemishes; whereas, it is extensively practiced with stock horses in the range country.

A combination of hand-mating followed by pasture-mating will extend the number of mares bred and increase settling percentage.

Hand-mating is practiced under a wide variety of conditions, ranging from rather casual selection of mares and sanitation conditions to those that are highly supervised with a veterinarian in attendance.

Stallions used with hand-mating should be adept at teasing mares. This may be done at a teasing pole, over a stall door, or any other sturdy fixture that does not injure the horses or attendants.

Signs of heat are frequent urination, vaginal discharge, and intensified interest in the stallion. As ovulation approaches, hormones released by the ripening follicle cause an intensification of these signs. The character of vaginal discharge may change from limited amounts of stringy consistency to profuse amounts of liquid consistency.

After the mare has been teased and found in heat, she may be hobbled or placed in a breeding stock. Hobbles have the advantage of convenience and safety to the mare, but may entail some risk to the operator, and stallions have been known to become entangled in them.

The mare's hindquarters may be washed in mild soap and rinsed, and her tail bandaged with a roller bandage. The stallion is allowed to mount quietly from directly behind the mare when ready. A stallion should not be permitted to be rough in the process of breeding. Front shoes should be removed before the breeding season.

How to Increase Your Percent Foal Crop

1. Breed only healthy animals.
2. Breed as often in the heat cycle as possible.
3. Pasture breed when practical.
4. Don't breed at foal heat.
5. Have mares in good condition, but not fat when bred.
6. Know the characteristics of each individual's heat cycle.
7. Tease mares regularly after breeding.
8. Have them pregnancy-checked by a competent veterinarian.

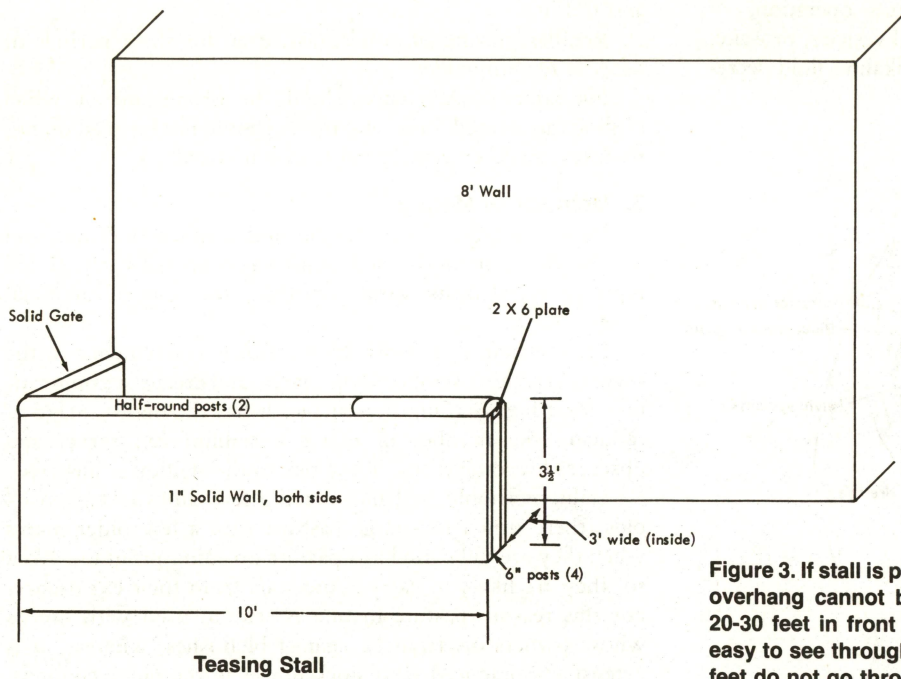

Figure 3. If stall is positioned against a building, be sure the roof overhang cannot be reached by a rearing horse. A colt pen 20-30 feet in front of the mare is very desirable. It should be easy to see through, but of mesh wire small enough that colt's feet do not go through.

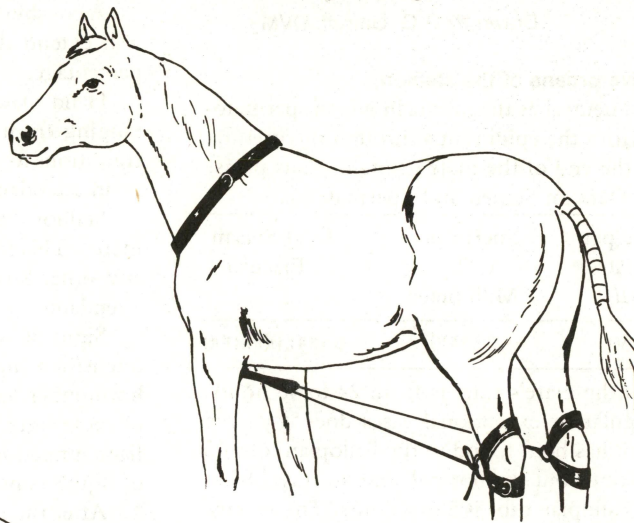
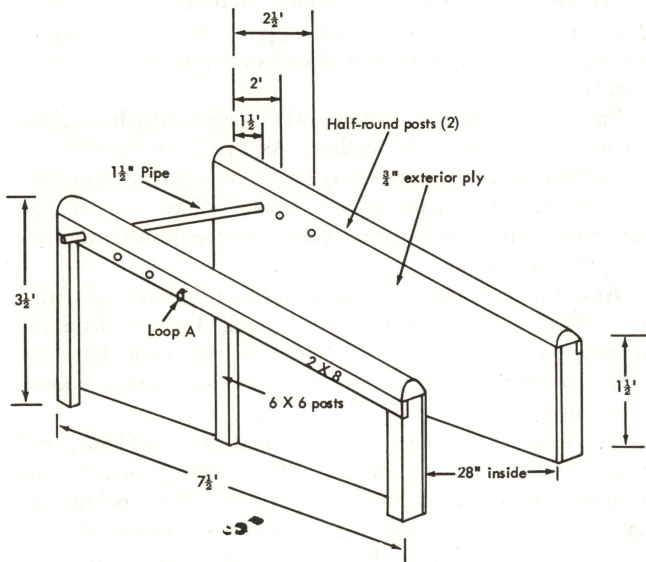

Figure 4. Most breeders use hobbles because of convenience and safety. Some insist on quick-release snaps ("panic snaps") where the rope attaches to the ring at each hock.



Breeding Stall

Figure 5. A 3/4-inch rope is attached to loop A, brought behind the mare above the hocks, and wrapped twice around the end of the pipe at the mare's right shoulder. The end of the rope is securely held by an attendant who can release it if necessary in an emergency.