

## Chimneys for Wood Stoves

Richard E. Phillips  
Department of Agricultural Engineering  
College of Agriculture

All wood burning stoves need a tight, well designed and constructed chimney to maximize efficiency and to minimize the danger of unwanted fire. Most homeowners who add a wood burning stove will also have to add a chimney. This guide explains chimney requirements and provides basic information on the construction of the two general types, masonry and prefabricated metal.

The chimney serves two major functions in stove operation. It provides a draft, or vacuum, which draws oxygen needed for combustion into the stove. It also discharges the products of combustion outside the living area. Some of the heat from the stove and occasional sparks are also discharged through the chimney. For this reason, chimneys must be carefully constructed and well maintained to prevent fires.

Draft is caused primarily by the natural rising of warm air (smoke) up the chimney. In general, the taller the chimney, the greater the draft. A warm chimney will provide greater draft than a cool chimney because a warm chimney does not cool the rising smoke. This is why stoves generally perform better after they have run long enough to warm the chimney than they do when they are first started. And for the same reason, chimneys which are located within the house have better draft than those located completely outside.

Outside air currents can affect draft if they swirl around obstructions and blow down the chimney rather than across the outlet. Eddy currents of air that affect draft are most often caused by wind blowing across nearby parts of the building roof. For this reason, certain clearances have been established to lessen the problem. A chimney must extend at least three feet above a flat roof and at least two feet above a roof ridge or any raised part of a roof within 10 feet. See Figure 1 for an illustration of these clearances.

Sometimes getting enough vertical clearance to prevent eddy currents from affecting chimney draft is impossible. This may be because of unusual heights of nearby trees. A hood or chimney cap can sometimes be used to prevent eddies from interfering with draft. Caps and hoods also minimize rain entry into the chimney during periods of non-use.

### Flue

The opening in the chimney through which smoke passes is called the flue. To provide adequate room for smoke passage and draft development, flues must be carefully sized in relation to stove capacity and chimney height. In general, flue size should be 25 percent larger than the size of the stove pipe which connects the stove to the chimney. This means a

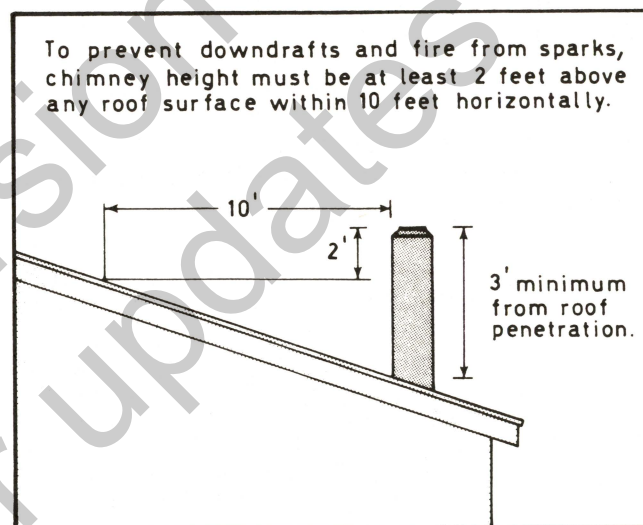

Figure 1. Required roof clearances.

stove with a six-inch diameter pipe would require at least an eight-inch flue; an eight-inch stove pipe requires a 10-inch flue, ect.

Smoke moves up the flue in a swirling pattern. Round flues are more efficient than square or rectangular ones because they offer little obstruction to the natural flow of smoke. For best performance, the inner surface of flues should be as smooth as possible.

One frequently asked question about chimneys for wood stoves is "Can a stove be connected to an existing flue that serves another appliance?" National Fire Protection Association (NFPA) requirements prohibit connecting a stove to a chimney flue serving a fireplace. This requirement has been incorporated into most building codes and insurance regulations. The NFPA recommends that each stove be connected to a separate flue. This reduces interference between units and increases the efficiency of each stove.

### Location

Maximum burning efficiency is obtained when chimneys are located as close as possible to the stove unit. The usual recommendation is to limit the length of connecting pipe between stove and chimney to 10 feet. UMC guide 1730, "Wood Stoves and Their Installation," provides additional information on connecting pipe and required clearances.

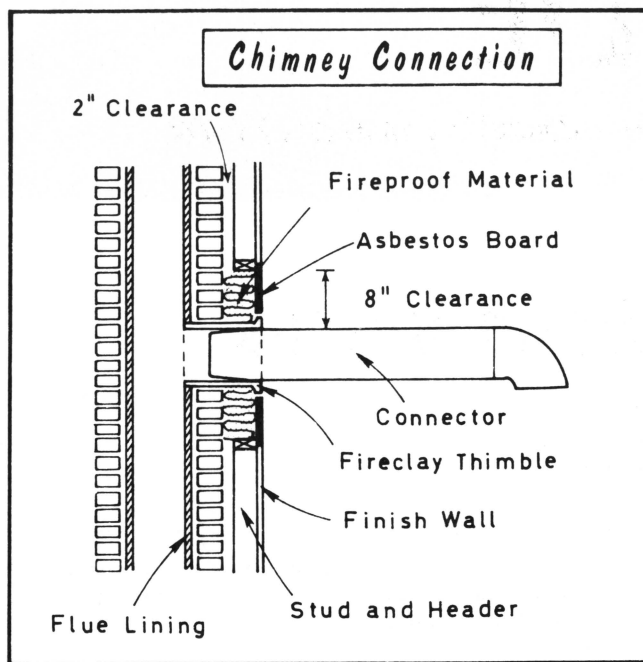

**Figure 2. Proper method of connecting stove pipe to the chimney.**

## Masonry Chimneys

Most chimneys in new and existing homes are constructed of non-combustible masonry material. This may be brick, concrete block, or some type of stone. Masonry chimneys are usually the heaviest part of the house and must be constructed on a concrete footing heavy enough to support this weight without settling. Chimney footings must extend below normal front depth and rest on undisturbed or well compacted soil. Footings should extend at least six inches beyond the edge of the chimney on all sides and should be eight inches thick for single story houses. Two story houses require chimney footings 12 inches thick to support the weight of the added height.

Masonry chimneys should be lined with vitrified fire clay tile (flue tile). This tile is designed to withstand rapid fluctuations in temperature without cracking and has a smooth surface that is easily cleaned. Flue tile should be at least  $\frac{5}{8}$  inch thick. It is available in several sizes. The most commonly used sizes in residential construction are 8 by 8 inches, 8 by 13, and 13 by 13 (outside dimensions). Flue tiles are connected together with cement mortar joints, struck smooth on the inside. There should be a one inch space between the outside of the flue tile and the surrounding masonry to reduce heat loss through the chimney and thus improve draft.

Masonry walls for chimneys less than 30 feet high must be at least four inches thick. If stone is used for the wall, a 12 inch minimum thickness is needed. A chimney which is exposed directly to the elements should have walls at least eight inches thick to provide added strength for withstanding weathering and wind.

Masonry units should be laid with cement mortar. A recommended mix is one part portland cement, one part hydrated lime, and 6 parts clean sand, measured by volume.

A chimney may contain more than one flue. Two flues may be placed side by side if the adjacent joints in the tile liners are separated vertically by at least seven inches.

Masonry chimneys must be separated from combustible material by at least two inches on all sides. This means that framing and other burnable material in walls, floors, ceilings, and roofs must stop at least two inches from the chimney. This two-inch space can be filled with asbestos cement board, sheet metal, or other non-combustible material.

Stove pipe connections to masonry chimneys are made through round masonry units called thimbles. These are constructed of fire clay and installed horizontally into the chimney wall. Thimbles must not extend into the chimney beyond the inner surface of the flue liner.

Soot and creosote will accumulate on the inner surface of chimneys. A tight fitting clean-out door should be installed at the base of the chimney to assist in cleaning.

## Prefabricated Chimney Units

Masonry chimney units cannot be easily added to many existing homes and are not practical in some new home designs. A prefabricated metal chimney unit may be the best choice for wood stoves or fireplaces in these home.

Prefabricated chimneys are easier to erect than masonry units, and although materials cost more, total unit cost will be nearly the same. These units are relatively light weight, need no heavy foundation, and can often be installed through a closet or unused room corner in an existing home. Tests by the National Bureau of Standards indicate similar performance for both prefabricated and masonry chimneys when used under similar circumstances.

Prefabricated chimneys used for wood stoves must bear the Underwriters Laboratory (UL) listed label and be designated as "all fuel" chimney units. UL listed "vent" type units are not satisfactory for use with wood stoves.

There are two general types of prefabricated chimneys available. They are the insulated unit and the triple walled unit. The insulated unit is constructed of inner and outer layers of metal (usually stainless steel) with the space between filled with one or more inches of non-combustible insulation. Triple walled units have three layers of metal and are designed so that air circulates between the layers and removes excess heat. Either type is satisfactory as long as it is UL listed.

Prefabricated chimneys are available in several sizes, and a variety of accessories are available to accommodate different types of installation. There is a required two-inch clearance between these units and combustible material, just as there is for masonry units.

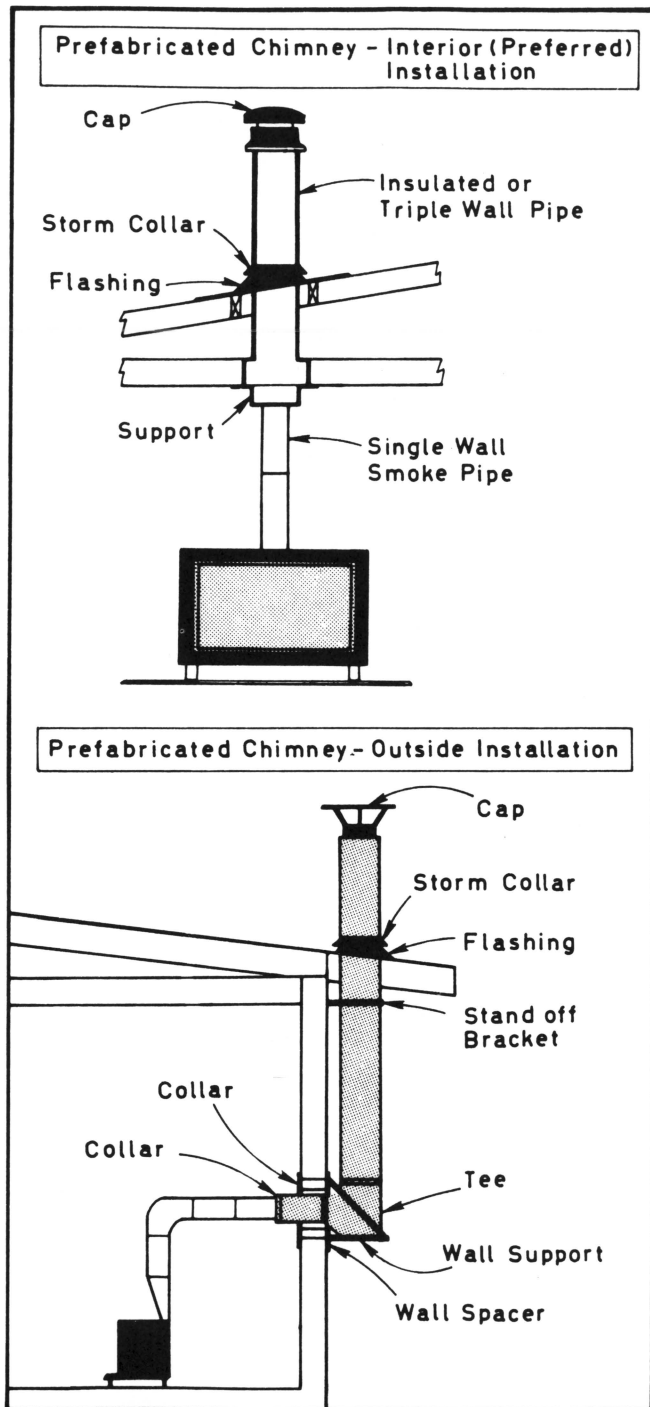

Figure 3. Two alternative methods of installing prefabricated chimneys.

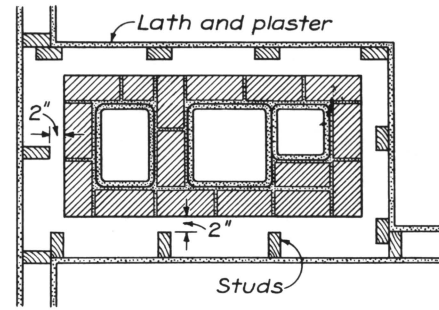

Figure 4. Chimney with proper arrangement of three flues. Bond division wall with sidewalls by staggering the joints of successive courses. Wood framing should be at least 2 inches from brickwork.

## Smoky Fires

Sometimes even properly constructed and operated stove-chimney combinations result in smoky fires. Each of the following items can cause smoky fires.

- **Chimney Obstructions.** Bird nests, fallen bricks, and a variety of other objects have all been found in chimneys. Any object which restricts the smooth flow of exhaust gases can cause smoky fires. A good cleaning is the solution to this problem.
- **Lack of Combustion Air.** Occasionally in a new, tightly constructed home or in a recently remodeled chimney unit, there will not be enough natural openings to supply air for the stove. This restricts the chimney draft and results in smoking. Opening a window slightly or providing some other source of outside air will usually eliminate this problem.
- Occasional smoking can be caused by:
  - a) **Unusual wind direction** resulting in abnormal eddy currents. If this is a persistent problem, extending chimney height or adding a cap may help.
  - b) **Burning green or wet wood or too cool a fire.** These can prevent the chimney from warming up and developing full draft. If wet or green wood must be burned, wait until the fire is going well and then mix it with dry wood to keep chimney temperature up.

■ Issued in furtherance of Cooperative Extension Work Acts of May 8 and June 30, 1914 in cooperation with the United States Department of Agriculture. Carl N. Scheneman, Vice President for Extension, Cooperative Extension Service, University of Missouri and Lincoln University, Columbia, Missouri 65211. ■ An equal opportunity institution.