

Acceleration-Induced Nonlocal Electrodynamics in Minkowski Spacetime

Uwe Muench
Friedrich W. Hehl*
Bahram Mashhoon

Department of Physics & Astronomy, University of Missouri,
Columbia, MO 65211, USA

Abstract

We discuss two nonlocal models of electrodynamics in which the nonlocality is induced by the acceleration of the observer. Such an observer actually measures an electromagnetic field that exhibits persistent memory effects. We compare Mashhoon's model with a new ansatz developed here in the framework of charge & flux electrodynamics with a constitutive law involving the Levi-Civita connection as seen from the observer's local frame and conclude that they are in partial agreement only for the case of constant acceleration. *Files kernel14.tex + kernel14a.ps + kernel14a.pst + kernel14b.ps + kernel14b.pst + kernel14c.ps, 2000-03-23*

1 Introduction

As pointed out by Einstein [1], in special relativity theory it is assumed that the rate of a fundamental (“ideal”) clock depends on its instantaneous speed and is not affected by its instantaneous acceleration. This is usually called the “clock hypothesis”; see [2, 3, 4] for more recent discussions of this

*Permanent address: Inst. Theor. Physics, Univ. of Cologne, 50923 Köln, Germany

assumption. The decay of elementary particles obeys this hypothesis very well as shown by Eisele [5] for the weak decay of the muon.

If we study electrodynamics, for instance, in an accelerated reference frame (see [6]), then we have to presuppose corresponding hypotheses for the measurement of the electric and magnetic fields, the electric charge, etc. In this way, we arrive at the *hypothesis of locality* that has been extensively investigated [7, 8, 9, 10, 11]. Replacing the curved worldline of the accelerated observer by its instantaneous tangent vector is reasonable if the intrinsic spacetime scales of the phenomena under consideration are negligibly small compared to the characteristic acceleration scales that determine the curvature of the worldline; otherwise, the past worldline of the observer must be taken into account. This would then result in a nonlocal electrodynamics for accelerated systems.

Nonlocal constitutive relations have been studied in the *phenomenological* electrodynamics of continuous media for a long time [12, 13]. In basic field theories, form-factor nonlocality has been the subject of extensive investigations. The main problem with such field theoretical approaches has been that they defy quantization. A review of nonlocal quantum field theories and their insurmountable difficulties has been given by Marnelius [14]. The present work is concerned with a benign form of nonlocality that is induced by the acceleration of the observer.

The hypothesis of locality refers directly to *acceleration*; therefore, one can develop an alternative approach in which the acceleration enters as the decisive quantity. This type of nonlocality, if it refers to time, would involve persistent memory effects. Materials with memory have been extensively studied. However, we are interested in the “material” vacuum – and in this context our paper is devoted to a comparison of two models involving acceleration-induced nonlocality.

2 Mashhoon’s model

The observational basis of the special theory of relativity generally involves measuring devices that are accelerated; for instance, static laboratory devices on the Earth participate in its proper rotation. The standard extension of Lorentz invariance to accelerated observers in Minkowski spacetime is based on the hypothesis of locality, namely, the assumption that an accelerated observer is locally equivalent to a momentarily comoving inertial observer. The

worldline of an accelerated observer in Minkowski spacetime is curved and this curvature depends on the observer's translational and rotational acceleration scales. The hypothesis of locality is thus reasonable if the curvature of the worldline could be ignored, i.e. if the phenomena under consideration have intrinsic scales that are negligible as compared to the acceleration scales of the observer. The accelerated observer passes through a continuous infinity of hypothetical comoving inertial observers along its worldline; therefore, to go beyond the hypothesis of locality, it appears natural to relate the measurements of an accelerated observer to the class of instantaneous comoving inertial observers.

Consider, for instance, an electromagnetic radiation field F_{ij} in an inertial frame and an accelerated observer carrying an *orthonormal tetrad frame* $e^i_\alpha(\tau)$ along its worldline. Here τ is its proper time, the Latin indices i, j, k, \dots , which run from 0 to 3, refer to spacetime coordinates (holonomic indices), while the Greek indices $\alpha, \beta, \gamma, \dots$, which run from $\hat{0}$ to $\hat{3}$, refer to (anholonomic) frame indices, and we choose the signature $(+, -, -, -)$. The hypothesis of locality implies that the field as measured by the observer is the projection of F_{ij} upon the frame of the instantaneously comoving inertial observer, i.e.

$$F_{\alpha\beta}(\tau) = F_{ij} e^i_\alpha e^j_\beta. \quad (1)$$

On the other hand, measuring the properties of the radiation field would necessitate finite intervals of time and space that would then involve the curvature of the worldline. The most general *linear* relationship between the measurements of the accelerated observer and the class of comoving inertial observers consistent with causality is

$$\mathcal{F}_{\alpha\beta}(\tau) = F_{\alpha\beta}(\tau) + \int_{\tau_0}^{\tau} K_{\alpha\beta}{}^{\gamma\delta}(\tau, \tau') F_{\gamma\delta}(\tau') d\tau', \quad (2)$$

where $\mathcal{F}_{\alpha\beta}$ is the *field actually measured*, τ_0 is the instant at which the acceleration begins and the kernel K is expected to depend on the acceleration of the observer. A nonlocal theory of accelerated observers has been developed [9, 10] based on the assumptions that (i) K is a convolution-type kernel, i.e. it depends only on $\tau - \tau'$, and (ii) the radiation field never stands completely still with respect to an accelerated observer. The latter is a generalization of a consequence of Lorentz invariance for inertial observers to all observers.

In the space of continuous functions, the Volterra integral equation (2) provides a unique relationship between $\mathcal{F}_{\alpha\beta}$ and $F_{\alpha\beta}$. It is possible to express (2) as

$$F_{\alpha\beta}(\tau) = \mathcal{F}_{\alpha\beta}(\tau) + \int_{\tau_0}^{\tau} R_{\alpha\beta}{}^{\gamma\delta}(\tau, \tau') \mathcal{F}_{\gamma\delta}(\tau') d\tau', \quad (3)$$

where R is the resolvent kernel and if K is a convolution-type kernel as we have assumed in (i), then so is R , i.e. $R = R(\tau - \tau')$. Assumption (ii) then implies that

$$R(\tau) = \frac{d\Lambda(\tau + \tau_0)}{d\tau} \Lambda^{-1}(\tau_0), \quad (4)$$

where R and Λ are 6×6 matrices and Λ is defined by (1) expressed as $\hat{F} = \Lambda F$ in the six-vector notation. Here \hat{F} denotes the field as referred to the anholonomic frame. This nonlocal theory, which is consistent with all observational data available at present, has been described in detail elsewhere [10].

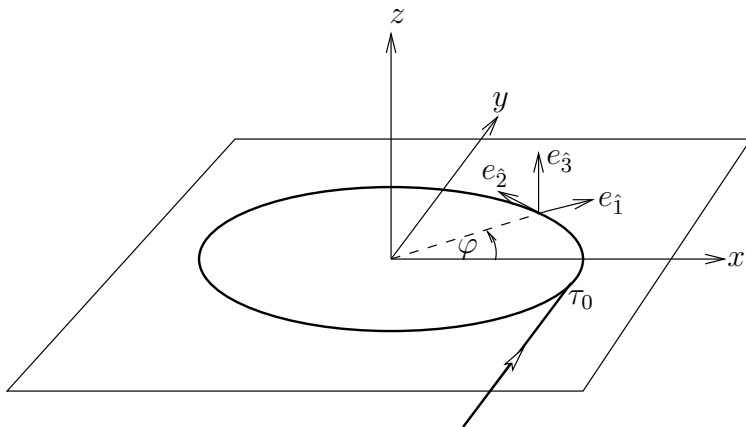

Fig.1. The path of an observer in space moving with constant angular velocity around the z -axis for $\tau > \tau_0$.

It proves interesting to provide a concrete example of the nonlocal relationship (2). Imagine an observer that moves uniformly in the inertial frame along the y -axis with speed $c\beta$ for $\tau < \tau_0$ and for $\tau \geq \tau_0$ rotates with uniform

angular speed Ω about the z -axis on a circle of radius r , $\beta = r\Omega/c$, in the (x, y) -plane, see Fig.1. In this case,

$$\begin{aligned} e_0^i &= \gamma (1, -\beta \sin \varphi, \beta \cos \varphi, 0), \\ e_1^i &= (0, \cos \varphi, \sin \varphi, 0), \\ e_2^i &= \gamma (\beta, -\sin \varphi, \cos \varphi, 0), \\ e_3^i &= (0, 0, 0, 1), \end{aligned} \tag{5}$$

in (ct, x, y, z) coordinates with $\varphi = \Omega(t - t_0) = \gamma\Omega(\tau - \tau_0)$. Here φ is the azimuthal angle in the (x, y) -plane and γ is the Lorentz factor. Using six-vector notation,

$$(F_{\alpha\beta}) \rightarrow \begin{bmatrix} \hat{\mathbf{E}} \\ \hat{\mathbf{B}} \end{bmatrix}, \quad (\mathcal{F}_{\alpha\beta}) \rightarrow \begin{bmatrix} \mathcal{E} \\ \mathcal{B} \end{bmatrix}, \tag{6}$$

one can show that with respect to the tetrad frame (5)

$$\mathcal{E} = \hat{\mathbf{E}} + \int_{\tau_0}^{\tau} \left[\boldsymbol{\omega} \times \hat{\mathbf{E}}(\tau') - \frac{\mathbf{a}}{c} \times \hat{\mathbf{B}}(\tau') \right] d\tau', \tag{7}$$

$$\mathcal{B} = \hat{\mathbf{B}} + \int_{\tau_0}^{\tau} \left[\frac{\mathbf{a}}{c} \times \hat{\mathbf{E}}(\tau') + \boldsymbol{\omega} \times \hat{\mathbf{B}}(\tau') \right] d\tau', \tag{8}$$

where \mathbf{a} is the constant centripetal acceleration of the observer and $\boldsymbol{\omega}$ is its constant angular velocity. These quantities can be expressed with respect to the triad e_A^i as $\mathbf{a} = (-c\beta\gamma^2\Omega, 0, 0)$ and $\boldsymbol{\omega} = (0, 0, \gamma^2\Omega)$. For an arbitrary accelerated observer, we expect that the relations analogous to (7) and (8) would be much more complicated.

Imagine now a general congruence of accelerated observers such that relations similar to (2) and (3) hold for each member of the congruence. The requirement that the electromagnetic field F_{ij} (or $F_{\alpha\beta}$) satisfy Maxwell's equations would then imply, via (3), that the field $\mathcal{F}_{\alpha\beta}$ would satisfy certain complicated integro-differential equations, which could then be regarded as the nonlocal Maxwell equations for $\mathcal{F}_{\alpha\beta}$. Instead of this system, we give here a different, but analogous, acceleration-induced nonlocal electrodynamics and study some of its main properties.

3 Charge & flux electrodynamics with a new nonlocal ansatz

The electrodynamics of charged particles and flux lines, see [15, 16] and the references cited therein, involves the electromagnetic field strength $F_{\alpha\beta}$ —that is defined via the Lorentz force law and is directly related to the conservation law of magnetic flux—as well as the electromagnetic excitation $\mathcal{H}^{\alpha\beta}$ that is directly related to the electric charge conservation. The corresponding Maxwell equations are metric-free and in Ricci calculus in arbitrary frames read (cf. [17, 18])

$$\partial_{[\alpha} F_{\beta\gamma]} - C_{[\alpha\beta}{}^{\delta} F_{\gamma]\delta} = 0, \quad (9)$$

$$\partial_{\beta} \mathcal{H}^{\alpha\beta} - \frac{1}{2} C_{\beta\gamma}{}^{\alpha} \mathcal{H}^{\gamma\beta} - \frac{1}{2} C_{\beta\gamma}{}^{\beta} \mathcal{H}^{\alpha\gamma} = \mathcal{J}^{\alpha}. \quad (10)$$

Here \mathcal{J}^{α} is the electric current and the C 's are the components of the object of anholonomicity:

$$C_{\alpha\beta}{}^{\gamma} := 2 e^i{}_{\alpha} e^j{}_{\beta} \partial_{[i} e_{j]}{}^{\gamma} = -C_{\beta\alpha}{}^{\gamma}. \quad (11)$$

Ordinarily for vacuum, we would have the constitutive equation

$$\mathcal{H}^{\alpha\beta} = \sqrt{-g} g^{\alpha\mu} g^{\beta\nu} F_{\mu\nu}. \quad (12)$$

However, this reformulation of electrodynamics allows for much more general constitutive relations between $\mathcal{H}^{\alpha\beta}$ and $F_{\alpha\beta}$. In particular, it is possible to develop a nonlocal *ansatz* based on a generalization of (12) along the lines suggested by Obukhov and Hehl [15]

$$\mathcal{H}^{\alpha\beta}(\tau, \xi) = \sqrt{-g} g^{\alpha\mu} g^{\beta\nu} \int \mathcal{K}_{\mu\nu}{}^{\rho\sigma}(\tau, \tau', \xi) F_{\rho\sigma}(\tau', \xi) d\tau', \quad (13)$$

where the kernel \mathcal{K} corresponds to the response of the medium and ξ^A , $A = 1, 2, 3$, are the Lagrange coordinates of the medium.

As an alternative to Mashhoon's model but along the same line of thought, see equation (2), one can develop an acceleration-induced nonlocal constitutive relation in vacuum via equation (13) by using the ansatz,

$$\begin{aligned} \mathcal{H}^{\alpha\beta}(\tau) &= \sqrt{-g} g^{\alpha\mu} g^{\beta\nu} \left[F_{\mu\nu}(\tau) \right. \\ &\quad \left. - c \int_{\tau_0}^{\tau} [\Gamma_{0\mu}{}^{\rho}(\tau - \tau') F_{\rho\nu}(\tau') + \Gamma_{0\nu}{}^{\rho}(\tau - \tau') F_{\mu\rho}(\tau')] d\tau' \right], \quad (14) \end{aligned}$$

where the integral is over the worldline of an accelerated observer in Minkowski spacetime as before. Here the response of the “medium” is simply given by the Levi-Civita connection of the accelerated observer in vacuum and the local constitutive relation (12) is recovered for *inertial* observers.

We recall that in an *orthonormal* frame the connection is equivalent to the anholonomicity, see [17]:

$$\Gamma_{\alpha\beta\gamma} := g_{\gamma\delta} \Gamma_{\alpha\beta}{}^{\delta} = \frac{1}{2} (-C_{\alpha\beta\gamma} + C_{\beta\gamma\alpha} - C_{\gamma\alpha\beta}) = -\Gamma_{\alpha\gamma\beta}. \quad (15)$$

If we invert (15), we find that $C_{\alpha\beta\gamma} = -2\Gamma_{[\alpha\beta]\gamma}$.

In the following, we explore the consequences of the new ansatz (14) for a general accelerated observer in Minkowski spacetime.

4 The new ansatz and the accelerating and rotating observer

It has been shown in [19, 20], and the references cited therein, that the *orthonormal* frame e_α of an arbitrary observer with local 3-acceleration \mathbf{a} and local 3-angular velocity $\boldsymbol{\omega}$ reads

$$\begin{aligned} e_{\hat{0}} &= \frac{1}{1 + \frac{\mathbf{a}}{c^2} \cdot \bar{\mathbf{x}}} \left[\partial_{\bar{0}} - \left(\frac{\boldsymbol{\omega}}{c} \times \bar{\mathbf{x}} \right)^{\bar{B}} \partial_{\bar{B}} \right], \\ e_A &= \partial_{\bar{A}}, \end{aligned} \quad (16)$$

where the barred coordinates are the standard normal coordinates adapted to the worldline of the accelerated observer. The coframe ϑ^α can be computed by inversion. We find

$$\begin{aligned} \vartheta^{\hat{0}} &= \left(1 + \frac{\mathbf{a}}{c^2} \cdot \bar{\mathbf{x}} \right) dx^{\bar{0}} = N dx^{\bar{0}}, \\ \vartheta^A &= dx^{\bar{A}} + \left(\frac{\boldsymbol{\omega}}{c} \times \bar{\mathbf{x}} \right)^{\bar{A}} dx^{\bar{0}} = dx^{\bar{A}} + N^{\bar{A}} dx^{\bar{0}}. \end{aligned} \quad (17)$$

In the (1 + 3)-decomposition of spacetime, N and $N^{\bar{A}}$ are known as *lapse function* and *shift vector*, respectively. The frame and the coframe are orthonormal. The metric reads as follows:

$$\begin{aligned} ds^2 = \eta_{\alpha\beta} \vartheta^\alpha \otimes \vartheta^\beta &= \left[\left(1 + \frac{\mathbf{a}}{c^2} \cdot \bar{\mathbf{x}} \right)^2 - \left(\frac{\boldsymbol{\omega}}{c} \times \bar{\mathbf{x}} \right)^2 \right] (dx^{\bar{0}})^2 \\ &\quad - 2 \left(\frac{\boldsymbol{\omega}}{c} \times \bar{\mathbf{x}} \right)_{\bar{A}} dx^{\bar{0}} dx^{\bar{A}} - \delta_{\bar{A}\bar{B}} dx^{\bar{A}} dx^{\bar{B}}, \end{aligned} \quad (18)$$

where $(\boldsymbol{\omega} \times \bar{\boldsymbol{x}})_{\bar{A}} = \epsilon_{\bar{A}\bar{B}\bar{C}} \omega^{\bar{B}} x^{\bar{C}}$, $\mathbf{a} = a^{\bar{A}} e_{\bar{A}}$, and $a^{\bar{A}} = e_i^{\bar{A}} a^i$.

Starting with the coframe, we can read off the connection coefficients (for vanishing torsion) by using Cartan's first structure equation $d\vartheta^\alpha = -\Gamma_\beta^\alpha \wedge \vartheta^\beta$ with $\Gamma_\beta^\alpha = \Gamma_{\bar{i}\beta}^\alpha dx^{\bar{i}}$. By construction, the connection projected in spacelike directions vanishes, since we have spatial Cartesian laboratory coordinates. Thus we are left with the following nonvanishing connection coefficients:

$$\begin{aligned}\Gamma_{\bar{0}\bar{0}A} &= -\Gamma_{\bar{0}A\hat{0}} = \frac{a_A}{c^2}, \\ \Gamma_{\bar{0}AB} &= -\Gamma_{\bar{0}BA} = \epsilon_{ABC} \frac{\omega^C}{c}.\end{aligned}\quad (19)$$

The first index in Γ is holonomic, whereas the second and third indices are anholonomic. If we transform the first index, by means of the frame coefficients $e^{\bar{i}}_\alpha$, into an anholonomic one, then we find the totally anholonomic connection coefficients as follows:

$$\begin{aligned}\Gamma_{\hat{0}\hat{0}A} &= -\Gamma_{\hat{0}A\hat{0}} = \frac{a_A/c^2}{1 + \mathbf{a} \cdot \bar{\mathbf{x}}/c^2}, \\ \Gamma_{\hat{0}AB} &= -\Gamma_{\hat{0}BA} = \frac{\epsilon_{ABC} \omega^C/c}{1 + \mathbf{a} \cdot \bar{\mathbf{x}}/c^2}.\end{aligned}\quad (20)$$

In general, of course, the translational acceleration \mathbf{a} and the angular velocity $\boldsymbol{\omega}$ are *functions of time*.

Let us return to (14). If we study the electric sector of the theory, we find, because of (19),

$$\mathcal{H}^{\hat{0}B}(\tau) = \eta^{\hat{0}\hat{0}} \eta^{BD} \left[F_{\hat{0}D}(\tau) - c \int_{\tau_0}^{\tau} (\Gamma_{\hat{0}\hat{0}}^C F_{CD} + \Gamma_{0D}^C F_{\hat{0}C}) d\tau' \right] \quad (21)$$

or

$$\mathbf{D} = \mathbf{E} + \int_{\tau_0}^{\tau} \left[\boldsymbol{\omega}(\tau - \tau') \times \mathbf{E}(\tau') - \frac{\mathbf{a}(\tau - \tau')}{c} \times \mathbf{B}(\tau') \right] d\tau'. \quad (22)$$

Similarly, for the magnetic sector, the corresponding relations read

$$\begin{aligned}\mathcal{H}^{AB} &= \eta^{AD} \eta^{BE} \left[F_{DE} \right. \\ &\quad \left. - c \int_{\tau_0}^{\tau} (\Gamma_{0D}^{\hat{0}} F_{\hat{0}E} + \Gamma_{0D}^C F_{CE} + \Gamma_{0E}^{\hat{0}} F_{D\hat{0}} + \Gamma_{0E}^C F_{DC}) d\tau' \right] \quad (23)\end{aligned}$$

or

$$\mathbf{H} = \mathbf{B} + \int_{\tau_0}^{\tau} \left[\boldsymbol{\omega}(\tau - \tau') \times \mathbf{B}(\tau') + \frac{\mathbf{a}(\tau - \tau')}{c} \times \mathbf{E}(\tau') \right] d\tau', \quad (24)$$

respectively. Clearly, for *constant* \mathbf{a} and $\boldsymbol{\omega}$ our nonlocal relations (22) and (24) are the same as (7) and (8) provided we identify \mathcal{H} with \mathcal{F} , i.e. we postulate that the field actually measured by the accelerated observer is the excitation \mathcal{H} . This agreement does not extend to the case of *nonuniform* acceleration, however, as will be demonstrated in the next section.

5 Nonuniform acceleration

To show that the new ansatz (14) is different from Mashhoon's ansatz (2) for the case of nonuniform acceleration even when we identify \mathcal{H} with \mathcal{F} , we proceed via contradiction. That is, let us assume that $\mathcal{F}_{\alpha\beta} = \mathcal{H}_{\alpha\beta}$ and hence from (22) and (24)

$$K(\tau) = \begin{bmatrix} K_{\boldsymbol{\omega}} & -K_{\mathbf{a}} \\ K_{\mathbf{a}} & K_{\boldsymbol{\omega}} \end{bmatrix}, \quad (25)$$

where $K_{\boldsymbol{\omega}} = \boldsymbol{\omega}(\tau) \cdot \mathbf{I}$ and $K_{\mathbf{a}} = \mathbf{a}(\tau) \cdot \mathbf{I}/c$. Here I_A , $(I_A)_{BC} = -\epsilon_{ABC}$, is a 3×3 matrix that is proportional to the operator of infinitesimal rotations about the e_A -axis. We must now prove that in general $R(\tau)$ given by (4) cannot be the resolvent kernel corresponding to $K(\tau)$ given by (25).

To this end, consider an observer that is accelerated at $\tau_0 = 0$ and note that for kernels of Faltung type in equations (2) and (3) we can write

$$\overline{\mathcal{F}} = (I + \overline{K})\overline{\widehat{\mathcal{F}}} \quad \text{and} \quad \overline{\widehat{\mathcal{F}}} = (I + \overline{R})\overline{\mathcal{F}}, \quad (26)$$

respectively, where $\overline{f}(s)$ is the Laplace transform of $f(\tau)$ defined by

$$\overline{f}(s) := \int_0^{\infty} f(\tau) e^{-s\tau} d\tau \quad (27)$$

and I is the unit 6×6 matrix. Hence, the relation between K and R may be expressed as

$$(I + \overline{K})(I + \overline{R}) = I. \quad (28)$$

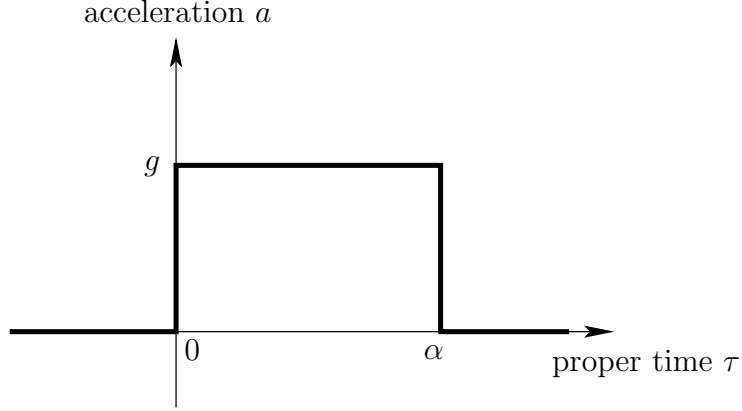

Fig.2. The acceleration of an observer that is uniformly accelerated only during a finite interval from $\tau = 0$ to $\tau = \alpha$.

Imagine now an observer that is at rest on the z -axis for $-\infty < \tau < 0$ and undergoes linear acceleration along the z -axis at $\tau = 0$ such that $a(\tau) = g > 0$ for $0 \leq \tau < \alpha$ and $a(\tau) = 0$ for $\tau \geq \alpha$ (see Fig. 2). That is, the acceleration is turned off at $\tau = \alpha$ and thereafter the observer moves with uniform speed $c \tanh(g\alpha/c)$ along the z -axis to infinity. Thus in (25), $K_{\omega} = 0$ and $K_{\mathbf{a}} = a(\tau) I_3/c$. On the other hand, one can show that (4) can be expressed in this case as

$$R(\tau) = a(\tau) \begin{bmatrix} U & V \\ -V & U \end{bmatrix}, \quad (29)$$

where $U = J_3 \sinh \Theta$, $V = I_3 \cosh \Theta$, and $(J_3)_{AB} = \delta_{AB} - \delta_{A3}\delta_{B3}$. Here we have set $c = 1$ and

$$\Theta(\tau) = \int_0^{\tau} a(\tau) d\tau = \begin{cases} g\tau, & 0 \leq \tau < \alpha, \\ g\alpha, & \tau \geq \alpha. \end{cases} \quad (30)$$

It is now possible to work out (28) explicitly and conclude that for

$$X(s) := \overline{a(\tau) \sinh \Theta}, \quad Y(s) := \overline{a(\tau) \cosh \Theta}, \quad Z(s) := \overline{a(\tau)}, \quad (31)$$

we must have

$$X = YZ, \quad Y = Z(1 + X). \quad (32)$$

These relations imply that

$$Y(s) = \frac{Z(s)}{1 - Z^2(s)}. \quad (33)$$

On the other hand, we have

$$Z(s) = \int_0^{\infty} a(\tau) e^{-s\tau} d\tau = \frac{g}{s} (1 - e^{-\alpha s}) \quad (34)$$

and

$$\begin{aligned} Y(s) &= \frac{1}{2} \int_0^{\infty} a(\tau) (e^{\Theta} + e^{-\Theta}) e^{-s\tau} d\tau \\ &= \frac{g}{2} \left[\frac{1 - e^{-(s-g)\alpha}}{s - g} + \frac{1 - e^{-(s+g)\alpha}}{s + g} \right]. \end{aligned} \quad (35)$$

We consider only the region $s > g$ in which $X(s)$ and $Y(s)$ remain finite for $\alpha \rightarrow \infty$. Comparing (35) with

$$\frac{Z}{1 - Z^2} = \frac{gs(1 - e^{-\alpha s})}{s^2 - g^2(1 - e^{-\alpha s})^2}, \quad (36)$$

we find that, contrary to (33), they do not agree except in the $\alpha \rightarrow \infty$ limit (see Fig.3). Therefore, we conclude that the two models are different if one considers *arbitrary* accelerations.

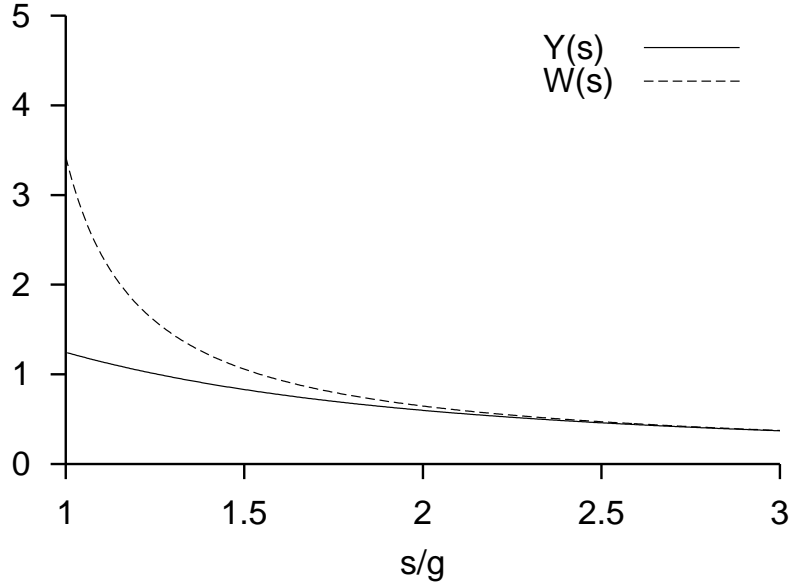

Fig.3. Plot of the functions $Y(s)$ and $W(s) := Z(s)/[1 - Z^2(s)]$ for $\alpha g = 2$.

6 Discussion

If one rewrites Mashhoon's nonlocal electrodynamics in the framework of charge & flux electrodynamics in vacuum by substituting the generalization of equation (3) for a congruence of accelerated observers in equations (9)–(12), one finds a rather complicated implicit nonlocal constitutive law. The Maxwell equations expressed in terms of the excitations (\mathbf{D}, \mathbf{H}) and field strengths (\mathbf{E}, \mathbf{B}) remain the same, a fact which is significant since otherwise the conservation laws of electric charge and magnetic flux would be violated.

In this paper, we have developed an alternative nonlocal constitutive ansatz within the framework of charge & flux electrodynamics such that the nonlocality is induced by the acceleration of the observer in a similar way as in Mashhoon's model.

An explicit example of nonuniform acceleration has been used to show that the two nonlocal prescriptions discussed here are in general different.

Acknowledgments: One of the authors (FWH) would like to thank Bahram Mashhoon and the Department of Physics & Astronomy of the University of

Missouri-Columbia for the invitation for a two-month stay and for the hospitality extended to him. This stay has been supported by the VW-Foundation of Hannover, Germany. We are grateful to Yuri Obukhov (Moscow) for highly interesting and critical discussions on nonlocal electrodynamics. Thanks are also due to Guillermo Rubilar (Cologne) for helpful correspondence.

References

- [1] A. Einstein: *The Meaning of Relativity*, 3rd ed. (Princeton University Press, Princeton, 1950). The hypothesis regarding accelerated rods and clocks is mentioned in a footnote on page 60.
- [2] S.R. Mainwaring and G.E. Stedman: *Accelerated Clock Principles in Special Relativity*. Physical Review **A47** (1993) 3611–3619.
- [3] R. Anderson, I. Vetharaniam and G.E. Stedman: *Conventionality of Synchronization, Gauge Dependence and Test Theories of Relativity*. Physics Reports **295** (1998) 94–180.
- [4] B. Mashhoon: *Electrodynamics in a Linearly Accelerated System*. Physics Letters **A122** (1987) 67–72.
- [5] A.M. Eisele: *On the Behavior of an Accelerated Clock*. Helvetica Physica Acta **60** (1987) 1024–1037.
- [6] P. Mittelstaedt und H. Heintzmann: *Laws of Physics in Accelerated Reference Frames (in German)*. Springer Tracts in Modern Physics (G. Höhler, ed.) **47** (1968) 185–225.
- [7] B. Mashhoon: *Limitations of Spacetime Measurements*. Physics Letters **A143** (1990) 176–182.
- [8] B. Mashhoon: *The Hypothesis of Locality in Relativistic Physics*. Physics Letters **A145** (1990) 147–153.
- [9] B. Mashhoon: *Nonlocal Theory of Accelerated Observers*. Physical Review **A47** (1993) 4498–4501.
- [10] B. Mashhoon: *Nonlocal Electrodynamics*. In: Proc. VII Brazilian School of “Cosmology and Gravitation” (Rio de Janeiro, August 1993), M. Novello, ed. (Editions Frontière, Gif-sur-Yvette, 1994), pp. 245–295.

- [11] B. Mashhoon: *Measurement Theory and General Relativity*. In: “Black Holes: Theory and Observation,” F.W. Hehl, C. Kiefer, and R. Metzler, eds. (Springer, Berlin, 1998), pp. 269–284; <http://arXiv.org/abs/gr-qc/0003014>.
- [12] L.D. Landau and E.M. Lifshitz: *Course of Theoretical Physics, Vol.8: Electrodynamics of Continuous Media*. Translated from the Russian. (Pergamon, Oxford, 1960), p. 249.
- [13] A.C. Eringen: *Electrodynamics of Memory-Dependent Nonlocal Elastic Continua*. *Journal of Mathematical Physics* **25** (1984) 3235–3249.
- [14] R. Marnelius: *Can the S Matrix be Defined in Relativistic Quantum Field Theories with Nonlocal Interactions?* *Physical Review* **D10** (1974) 3411–3430.
- [15] F.W. Hehl and Yu.N. Obukhov: *How does the Electromagnetic Field Couple to Gravity, in particular to Metric, Nonmetricity, Torsion, and Curvature?* In: *Testing Relativistic Gravity in Space*. Proc. 220th Heraeus Seminar (22–27 August 1999), C. Lämmerzahl, C.W.F. Everitt, and F.W. Hehl, eds. (Springer, Berlin, 2000); <http://arXiv.org/abs/gr-qc/0001010>.
- [16] Yu.N. Obukhov and F.W. Hehl: *Space-Time Metric from Linear Electrodynamics*. *Physics Letters* **B458** (1999) 466–470.
- [17] J.A. Schouten: *Tensor Analysis for Physicists*. 2nd edition. (Dover, Mineola, New York, 1989).
- [18] E.J. Post: *Formal Structure of Electromagnetics* (North Holland, Amsterdam, 1962; and Dover, Mineola, New York 1997).
- [19] F.W. Hehl and W.-T. Ni: *Inertial Effects of a Dirac Particle*. *Physical Review* **D42** (1990) 2045–2048.
- [20] F.W. Hehl, J. Lemke, and E.W. Mielke: *Two Lectures on Fermions and Gravity*. In: *Geometry and Theoretical Physics*, Proc. of the Bad Honnef School (12–16 Feb. 1990), J. Debrus, A.C. Hirshfeld, eds. (Springer, Berlin, 1991), pp. 56–140.