

PERFORMANCE IMPACTS DUE TO NUMBER PORTABILITY UNDER VARIOUS
ROUTING SCHEMES

A Thesis
IN
Computer Science

Presented to the Faculty of the University
of Missouri–Kansas City in partial fulfillment of
the requirements for the degree

MASTER OF SCIENCE

by
XUAN LIU

B. S., College of Informatics and Engineering, China University of Geosciences, Wuhan,
China, 2003

Kansas City, Missouri
2010

© 2010

XUAN LIU

ALL RIGHTS RESERVED

PERFORMANCE IMPACTS DUE TO NUMBER PORTABILITY UNDER VARIOUS
ROUTING SCHEMES

Xuan Liu, Candidate for the Master of Science Degree

University of Missouri–Kansas City, 2010

ABSTRACT

Number portability allows a user to keep her telephone number as she moves to another provider. Number portability has been adopted by more and more countries around the world. A number that has a new provider is called a ported number. Traversal of a call to a ported number may involve three different networks: the Originating Network where the call originates, the Donor Network who initially assigned the telephone number to the subscriber, and the Recipient Network that currently hosts the subscriber's number. Currently, there are four major schemes used for routing a call to ported numbers. As of now, there has been very little quantitative study on how these schemes perform as more and more numbers are ported since there has been an increasing trend of more subscribers choosing number portability; therefore, employing a more stable and efficient routing scheme is important. In this paper, we present a simulation study of the four routing schemes for number portability and discuss their performances under various

scenarios from a connection setup delay point of view. From the simulation results, we show that of the four schemes, the ACQ scheme shows more stable performance to the ported rate, and its performance is not much affected by the system load. However, at a low ported rate, other schemes can be reasonably competitive, particularly, from the total routing delay's perspective, the OR scheme shows better performance, because it has less external links and less facilities; while with a lower ported rate, the QoR scheme is less relatively affected by its components' service rate.

APPROVAL PAGE

The faculty listed below, appointed by the Dean of the School of Computing and Engineering, have examined a thesis titled “Performance Impacts Due to Number Portability Under Various Routing Schemes,” presented by Xuan Liu, candidate for the Master of Science degree, and hereby certify that in their opinion it is worthy of acceptance.

Supervisory Committee

Deep Medhi, Ph.D., Committee Chair
Department of Computer Science & Electrical Engineering

Baek-Young Choi, Ph.D.
Department of Computer Science & Electrical Engineering

Ken Mitchell, Ph.D.
Department of Computer Science & Electrical Engineering

CONTENTS

ABSTRACT	iii
LIST OF ILLUSTRATIONS	vii
LIST OF TABLES	ix
ACKNOWLEDGEMENTS	ix
Chapter	
1 INTRODUCTION	1
1.1 Overview of Number Portability	1
1.2 Problem Definition	3
1.3 Related Work	4
2 Number Portability Routing Schemes over SS7	5
2.1 SS7 Overview	6
2.2 Number Portability Routing Schemes	14
3 Modeling	23
3.1 Routing Models	23
3.2 CSIM Environment	27
3.3 Parameters	29
4 Methods and Results	33
4.1 Scenario Design	33
4.2 Simulation Methods and Tools	37
4.3 Results and Analysis	41
5 Summary	58
6 Future Work	60
Appendix	
A Various Link Delay Distribution Test	61
B Various External Link Delay Test	63
REFERENCE LIST	65
VITA	67

LIST OF ILLUSTRATIONS

Figure		Page
1	SS7 Architecture	10
2	SS7 Protocol Stack Model	11
3	Onward Routing	17
4	Call Dropback	18
5	Query on Release	19
6	All Call Query	19
7	OR Scheme Modeling	24
8	Modeling of Four Routing Schemes	26
9	States of a CSIM Process	28
10	Reference Point Scenario	42
11	Case I – Behavior of Four Schemes When Service Rate is Changed at NPDB	44
12	Case I – Relative Growth Rate of Total Routing Delay	45
13	Case II (a-1) – Behavior Pattern When Reducing Service Rate at DN	47
14	Case II (a-2) – Relative Growth Rate of Total Routing Delay Due to DN Changes Service Rate	48
15	Case II (b-1) – Delay Pattern When Reducing Service Rate at ON	49
16	Case II (b-2) – Relative Growth Rate of Total Routing Delay Due to ON Changes Service Rate	51

17	Case II (c-1) – Delay Pattern When Reducing Service Rate at RN	52
18	Case II (c-2) – Relative Growth Rate of Total Routing Delay Due to RN Changes Service Rate	53
19	Performance Impact on Onward Routing Scheme Due to Increasing Ser- vice Time at Different Facilities	54
20	Performance Impact on Query on Release Scheme Due to Increasing Ser- vice Time at Different Facilities	54
21	Performance Impact on Call Dropback Scheme Due to Increasing Service Time at Different Facilities	54
22	Performance Impact on All Call Query Scheme Due to Increasing Service Time at Different Facilities	54
23	Delay Pattern When Reducing Arrival Rate of Incoming Calls	56
24	Performance Impact Due to Different Link Delay Distributions	62
25	Performance Impact Due to Different External Link Delay	64

LIST OF TABLES

Table		Page
1	Parameter – Notations	30
2	Parameter – λ_{calls}	31
3	Parameter – μ_{dbServ}	32
4	Parameter – $\mu_{netServ}$	32
5	Reference Point Scenario Parameters	34
6	Scenario One - Case I - Parameter Values	35
7	Scenario One - Case II - Parameters Values	36
8	Scenario Two - Parameter Values	37
9	Results Obtained Based on Various Seeds	38
10	Student-t Distribution Table	40

ACKNOWLEDGEMENTS

I would like to thank my academic advisor Dr. Deep Medhi for his guidance during my thesis research. This thesis work is my first research, and Dr. Medhi gives me a valuable mentoring from finding a research topic to writing papers. On the other hand, I would like to thank Dr. Baek-Young Choi and Dr. Ken Mitchell from Department of Computer Science and Electrical Engineering for their advice on my thesis work.

I would like to thank my lab mates at the Computer Networking Research Laboratory (CoNReL) for their discussion and critiques. Specifically, I am thankful to my senior lab mate Haiyang Qian for his kindly suggestions in various aspects which helped me a lot in my thesis work.

Furthermore, I would like acknowledge my entire family for their support and encouragement during the whole study of my master study.

CHAPTER 1

INTRODUCTION

The evolution of telecommunication industry has brought considerable changes to our life day by day since the first telephone was invented. For a very long time in the past, Public Switch Telephone Network(PSTN), which provides fix communication service, was the only option for people to make calls with others. In 1980s of the Twentieth Century, Global System for Mobile Communication (GSM) offered another choice to users. It was the pioneer who introduced mobile telephony system to our world, and even today, GSM is still the most popular standard. Nowadays, no matter people are served by PSTN or GSM, Number Portability is not a fresh technology, although they might not familiar with this terminology itself. Customers has the right to switch their telephony service to another provider who offers less expense or better service plans while retaining their phone numbers.

After over two decades' development, there has been several types of Number Portability, and four primary schemes for routing calls to ported numbers are widely applied in multiple countries respectively, based on their specific requirement.

1.1 Overview of Number Portability

Wireline telecommunication industry had been significantly monopolized for a long time before the Telecommunication Act of 1996 finally was accepted as a law in

United States. [4] With a new technical terminology introduced, the 1996 Act specified all current and future local exchange providers' responsibility to implement number portability.

No matter in the traditional Public Switch Telephone Network (PSTN), or in the modern cellular network, number portability refers to the ability of subscribers to keep their telephone numbers when transferring to another service provider, moving to a new location or change their service type.

It was an significant milestone when number portability was first proposed. With the deployment of number portability, we expected a potential revolution in telecommunication service with more liberalize competitions and less monopolization. Especially for local telephony service, number portability encourages service providers to concern more proper service for their subscriber based on their demands. On the other hand, from the end-user's perspective, number portability would be more welcome, and it gives the subscribers an option that they can change service operators, service types, or location without changing their phone numbers. This benefit is more obvious in the cellular network. It brings a unique advantage of mobility and rapid activations [6]. By choosing number portability, customers can pursue better service or lower rate with a new operator, and they don't need to worry about notifying family, friends or business partners [6].

Number portability, on both landlines and mobile phones, has been available and implemented in many counties and areas all over the world. US and Hong Kong were the pioneers who first deployed local number portability for fixed-line telephone in the

world, and this was required by government as well. Since then, more and more countries took part in. Up to now, six countries in America, ten countries and areas in Asia, twenty countries in Europe, two countries in Oceania, and one country in Africa have had number portability available for landlines. For the mobile number portability, over forty countries have been or are about to implementing it. According to various the percentage of subscribers choosing number portability, and the number portability database used, different routing schemes are deployed in different country when supporting service provider portability [10], which is the primary form of number portability.

1.2 Problem Definition

The goal of our work is to study the performance impacts due to number portability under various routing schemes. Four different routing methods [10] [14] can be used for service provider number portability across the PTSN environment. We built up the models made simulation for each scheme with CSIM, which is a development toolkit for simulation and modeling. With the assumption that all calls have been successfully originated and are routed in SS7 network [15], to achieve the goal of our work, we carry out a series of tasks. (1) Understand how message traffic is routed at the MTU3 layer [15] of signalling network and how signalling network is involved in these four schemes. (2) Study the SS7 link traffic engineering and pick proper parameters which would impact the routing performance. (3) Design diverse scenarios for simulations to compare the performance between four routing schemes.

1.3 Related Work

In this section, we will briefly discuss the current literatures.

An overview of different methods in implementing number portability, and cases studies on the impacts of deploying number portability in the Netherlands, UK, and USA based on the routing model used are provided in [6]. This presents a monthly churn due to porting in various countries, but does not discuss the performance of the routing scheme used in those countries. [9] explains the reasons why the QoR and OR schemes have been used for Operator Number Portability in Switzerland, and make comparisons among the four routing schemes of number portability. But all these are very high level comparisons about cost and the routing mechanisms, and do not give much discussion about performance impact on call setup delay due to ported numbers.

In [12], the author discusses the possibility of using ENUM for number portability in VoIP and IMS networks, and addresses that ENUM service is able to potentially solve the number portability across multiple network types. [13] focuses on the AIN implementation for number portability and proposed a cache approach to make address transfer faster. By using AIN query, the network overhead can be reduced. [12] presents an idea for future number portability over multiple types of networks, and [13] presents a method to improve query performance for long-term number portability, so both aspects are not discussed in this paper.

CHAPTER 2

NUMBER PORTABILITY ROUTING SCHEMES OVER SS7

Number portability is widely implemented in PSTN, which now includes both fix-line and mobile digital telephone systems. Being the all-digital network, PSTN put forward advanced requirements on signaling system. To integrated into the existing PSTN without disturbing it, Signaling System NO.7 (SS7) was deployed by using the timeslots and trunk facilities in PSTN network. As number portability is involved, both call routing and SS7 messaging are affected.

Based on various application, number portability can be classified into different categories. The portability of toll-free 800 numbers that we are familiar with belongs to the non-geographic number portability (NGNP) [10]. Correspondingly, geographic number portability is another main type. Within this type, there are three sub-categories: operator portability or service provider portability (SPNP), location portability and service portability. According to the current deployment of number portability in the countries all over the world, we find that SPNP is the primary form. Therefore, from the routing perspective of view, we study four different schemes currently implemented over PSTN to compare their performance due to the number portability.

In order to understand how call routing is impacted within the four schemes respectively on signaling links, we will first briefly take an overview about SS7 network, and then get into the details for each number portability routing scheme.

2.1 SS7 Overview

By introducing Signaling System NO.7 to the telephone network system, the control messages are no longer sent over the trunks in PSTN, but go through the signaling links of SS7 channels. In this way, the call set up and tear down delay is shorted significantly, and it reduces the payload in the trunk network as well. [19] On the other hand, SS7 is also used for number resolution, billing mechanisms or short message service by exchanging some specific messages.

Unlike the traditional in-band signaling, SS7 uses an out-of-band signaling mechanism to build a data network which provides telecommunication signalling separated channels from the trunk network, so that this system is able to present reliable topology and stand-alone infrastructure integrated with the public switch telephone network.

2.1.1 SS7 Architecture

Similar to the Internet network, the components of Signaling System NO.7 network model are nodes and links, but in specific terms. The nodes in SS7 network are named signaling points (SPs), which can be classified into three types based on their functionalities, and they are assigned specific numbers respectively. The signaling links between two signaling points are called a link set [8].

Like the general routing mechanism in any network, there are two ways to route the signaling messages in SS7. For any two SPs, they can be directly connected by a link set. Alternately, there may be one or more intermediate SPs between them. Therefore, messages can be routed either directly to the destination or via the intermediate SPs which

transfer messages at the network later.

Next we will discuss the specific roles for each type of SPs and signaling links respectively.

2.1.1.1 SS7 Nodes

Although termed in Signaling Points, they have different names according to their responsibilities.

- **Service Switching Points (SSP)**

SSP is integrated with a telephony switch which supports SS7 protocols at any level of the telephone network. Although SS7 is a separate signaling system from the traditional trunk network and it's used to set up and tear down calls, it cannot be accessed directly from the end user. Thus, we can consider a switch with SSP interface is a signaling point in SS7, and the other interface of it receives voice calls from trunks. In other words, this signaling point type is used to convert the voice signal into digital signal and then initialize the call processing. Moreover, it also helps to route a call to its destination.

- **Service Transfer Points (STP)**

STPs act as routers in an SS7 network. Like the regular routers in IP network, STPs take the responsibility for relaying signaling messages between SSPs at the network layer. Two STPs can be either mated pair or non-mated pair, based on which region they are located.

- Service Control Points (SCP)

An SCP is another signaling point to provide database access services via upper-layer SS7 protocols. Take the 800-number services as an example, the SCPs access to the 800 Number Service Management System (SMS/800) Administration Center so that it can fetch information from SMS/800. Another example for the application of SCP is local number portability, which will be discussed later. In this case, a Number Portability Database (NPDB) is involved, which contains the routing information for the telephone numbers ported out from the Donor Network. Thus, an SCP is like an interface to access databases.

Contract with STPs, SSPs and SCPs can also be called as Signaling End Points (SEPs)

2.1.1.2 SS7 Links

In today's telephony network, setting up or tearing down calls are controlled by signaling messages, and billing management or other operator services are achieved in SS7 by sending signaling messages as well. The physical mediums between any two SPs for routing signaling messages are signaling links. The bandwidth for the signaling link is usually 64kbps or 56kbps, and higher-speed links have been introduced in recent years as well. As we mentioned earlier, to support higher bandwidth, a group of links could be between two directly connected SPs, and this group of links is given the name link set. There might be 16 links at most in a link set.

According to which two types of SPs are connected and where are they located,

there are six types of signaling links.

1. Acting as routers, STPs can stand at multiple levels in the hierarchy of SS7 networks. Three of the six types of links are used to connect STPs, and we can divide these into three sub-groups.

- Bridge link (B-link): This type of link connects STPs which are at the same level of the inter-network but not mated with each other.
- Cross link (C-link): The cross links are used to connect the mated-pair STPs
- Diagonal link (D-link): The D-links are the links between two non-mated STPs located at different hierarchy levels in SS7 network.

2. Two signaling end points can be directly connected by F-links, which refers to fully associated link. In other words, with F-link, two SSPs or an SSP and an SCP can communicate directly.

3. However, without F-link, it's necessary to have at least one STP between an SSP and an SCP. Therefore, the last two types of signaling links are introduced:

- Access link (A-link): SSPs or SCTs can access their primary home STPs by A-links.
- Extended link (E-link): With E-link, the SSP can access the STP which does not serve as its primary home STP.

Fig. 1 presents a general SS7 network architecture with all types of SPs and signaling links.

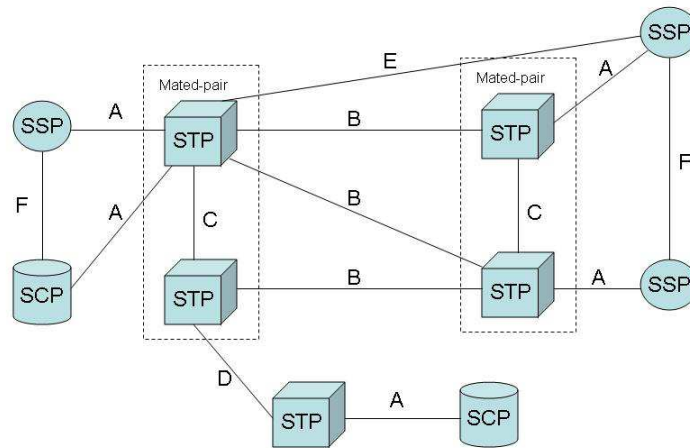

Figure 1: SS7 Architecture

2.1.1.3 Point Code

From the routing perspective of view, each signaling point is uniquely identified by an address in SS7 network, like the IP address in the IP network. The address for an SP is specifically termed as Point Code. Therefore, in the routing table, point codes might be stored as Originating Point Code (OPC) or Destination Point Code (DPC), and this depends on the roles SPs play in the SS7 network, i.e. originating the call or as the destination.

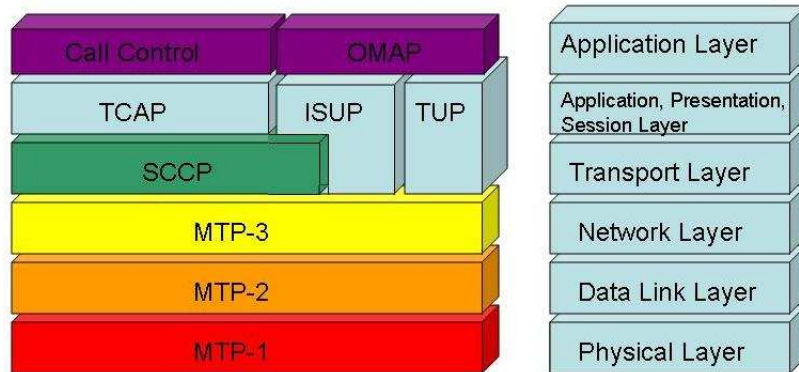

Figure 2: SS7 Protocol Stack Model

2.1.2 SS7 Protocol

In the last section, we briefly introduced primary components of SS7, which are SPs and signaling links, and each SP has a unique address. Call control information or other signaling messages are sent between SPs over signaling links, as the packets are transferred between nodes in IP network. Therefore, it's not hard to imagine that SS7 protocol stack model is somewhat similar to the OSI model. In other words, it's easier to understand SS7 protocol by comparing it to the OSI model.

Next, we will look into the model of SS7 protocol stack. Fig. 2 shows how SS7 protocol stack related to OSI. From the implementation aspect, we can divide the SS7 stack into two parts, which are Message Transfer Part (MTP) and User Part .

2.1.2.1 Message Transfer Part

The bottom three layers in SS7 stack present similar functionality as the ones in OSI model, and they belong to MTP. Namely, Message Transfer Part has three levels:

Message Transfer Part Level-1 (MTP-1), Message Transfer Part Level-2 (MTP-2), Message Transfer Part Level-3 (MTP-3), and they are equivalent to physical layer, data link layer and network layer of OSI model respectively.

MTP provides effective and reliable transport mechanism for SS7 signaling messages, and each MTP level is responsible for different task.

As described in ITU-T Q.702 [3], by specifying the requirement of both physical and electrical interfaces for signaling data links devices, MTP-1 allows bidirectional transmission, which refers "two data channels operating in opposite directions" [3] within the a signaling data link. The general bandwidth requirement for interfaces are 64kbps in digital networks, and in North America area, 56kbps bandwidth narrowband links are still common.

On top of MTP-1, MTP-2 provides error detection, retransmission mechanism and other functional methods over signaling links to make sure that signaling messages transmission is going well. Before sent out, the signaling messages are divided into multiple packets, or signal units, and then they go to the channel in sequence. The MTP-2 message units contain the transfer control information.

Over MTP-2, it is MTP-3 where routing functions are implemented based on the point codes of signaling points. The primary message unit at this layer is Message Signalling Unit (MTU), and it's length can be up to 278 bytes. Besides including the same fields in the MTP-2 packet, an MTU contains one more field for various call services in details. However, no matter what kind of service information it's about, there are three basic elements are always needed for the network layer, which are destination point

code (DPC), originating point code (OPC) and signaling link selection (SLS). Those three pieces of information consist a routing label. Thus, the MTU indicates the source and destination SPs when making the routing choices. On the other hand, by implement signaling network management functions [8], on MTP-3 the link status and routing tables can be monitored and updated.

2.1.2.2 User Part

The User Part, which is also the fourth layer of SS7 protocol stack, is more correspond to the application layer, presentation layer or other upper layers of the OSI model. Directly on top of MTP-3 are Signaling Connection Control Part (SCCP), ISDN User Part (ISUP) and Telephone User Part (TUP). From Fig 2.2, we can see that part of ISUP is over SCCP. The last user part is Transaction Capabilities Application Part (TCAP), and it's completely over SCCP. TCAP messages consist the primary traffic flow to Number Portability Database (NPDB), so we will briefly introduce SCCP and TCAP in this section.

Signaling Connection Control Part (SCCP) is like a transport layer protocol. From the connection control perspective, SCCP is equivalent to both TCP and UDP, which provide connection-oriented and connectionless network service respectively. With those services, SCCP is able to support both circuit-related or noncircuit-related transmission. Moreover, it allows extended routing methods that not limited to one address type. At this layer, in addition to indicate the code points for routing purpose, two more options for the address type are available. The first is Subsystem Number (SSN) [8], and the other

is Global Title (GT). Thus, in SCCP signaling messages, three pieces of information are included: Address Type, source address and destination address, and meanwhile, the messages will be embedded into the Signaling Information Field of MSU packets.

As an application layer protocol, TCAP provides transaction services and management for subsystems like SCPs.

2.2 Number Portability Routing Schemes

Our goal is to compare the performance impacts due to the different number portability routing schemes. Thus, we need to study the delay for routing a call to a ported number, and it is part of the post dial delay. When a subscriber choose number portability, how to route a call to his number will directly affect the delay. In this section, we will look into details about number portability routing schemes.

2.2.1 Terminologies

Before getting into the routing schemes, we need to be familiar with several facilities involved.

2.2.1.1 Network Operators

There are three components when we consider number portability routing. To simplify the model, we assume that there is no intermediate network between any two network operators [10].

- Donor Network: The network operator who initially assigned the telephone number to the subscriber.

- **Originating Network:** The network operator which originates the calls.
- **Recipient Network:** The network operator where the subscriber transfers to host his telephone number.

Based on the definition above, we can see that the Donor Network of a number is never changed, but the Recipient Network does not need to be fixed, depending on which network actually hosts the number.

Sometimes one network operator can play multiple roles. Donor network and originating network could be the same operator, for example, User A and B are both AT&T subscribers, so AT&T is the donor network for both of them. After user B ports his number to Sprint service, when A makes a call to B, AT&T is also the originating network. This is the specific case. To simulate a more general situation, we consider donor network, originating network and recipient network are different network operators.

2.2.1.2 Number Portability Database

Number Portability Database (NPDB) stores the ported number information including the routing information, i.e. Location Routing Number (LRN) used in the North America Numbering Plan (NANP). When NPDB receives the query request, it will send back the ported dialed number and corresponding routing number. The routing numbers are returned as routing addresses in the network.

Two kinds of NPDB can be applied for the number portability service: internal number portability database (Internal NPDB) and centralized number portability database (Centralized NPDB). Being named as Internal NPDB, it is an NPDB within the donor

network, and contains the information about numbers that were ported out from the donor network only. From the SS7 network components' perspective, the Internal NPDB is integrated with the donor network's SCP, which accepts TCAP messages from STP or SSP directly. However, the Centralized NPDB is more independent. It is managed and maintained by a third party, and contains the ported number information from multiple network operators. Thus, the TCAP traffic could be somewhat high at the centralized NPDB.

2.2.2 Routing Schemes

Number portability brought dynamic routing issue to our telecommunication networks, so four basic routing schemes for SPNP, the primary form of number portability, were deployed to ensure effectively delivering calls to ported number based on different cases.

As illustrated in the internet draft about NP overview [10], all intermediate or transit networks are not considered. Thus, only the five basic components are included: donor network, originating network, recipient network and two forms of NPDB. Let's assume that User #A makes a call to User #B, #B used to be with donor network, but currently moves to the recipient network.

2.2.2.1 Onward Routing (OR)

OR scheme, as shown in Fig. 3, uses internal NPDB instead of centralized NPDB. When generating a call from #A to #B, the originating network will firstly deliver the call to the Donor Network as if #B were not ported out. The Donor Network realizes that the

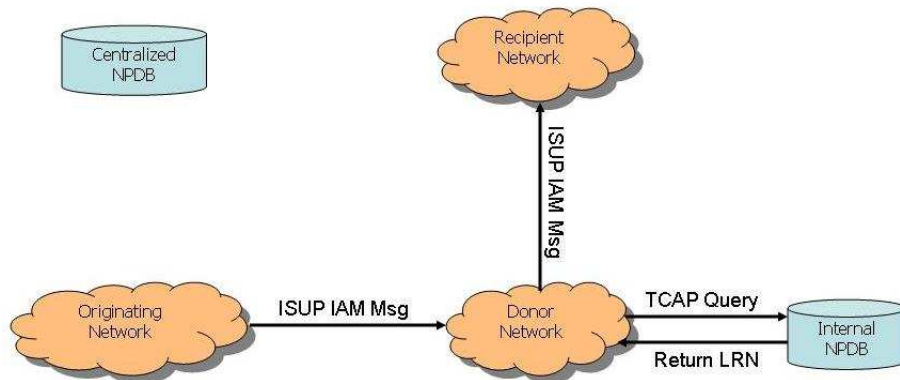

Figure 3: Onward Routing

#B has been ported out, so it sends a query request to its Internal NPDB. The Internal NPDB then returns a message containing the dialed ported number and its routing numbers to the Donor Network. After that, the Donor Network uses the routing information to forward that call to the Recipient Network and finally set up the call from #A to #B.

2.2.2.2 Call Dropback (CD)

The Call Dropback scheme is somewhat similar to OR as shown in Fig. 4. The only difference is the Donor Network won't forward the call to Recipient Network after getting the routing information from Internal NPDB, but it will send an SS7 REL message back to the Originating Network to release the circuit, and inform it the routing information as well. Then the Originating Network will route the call to the Recipient Network where #B resident.

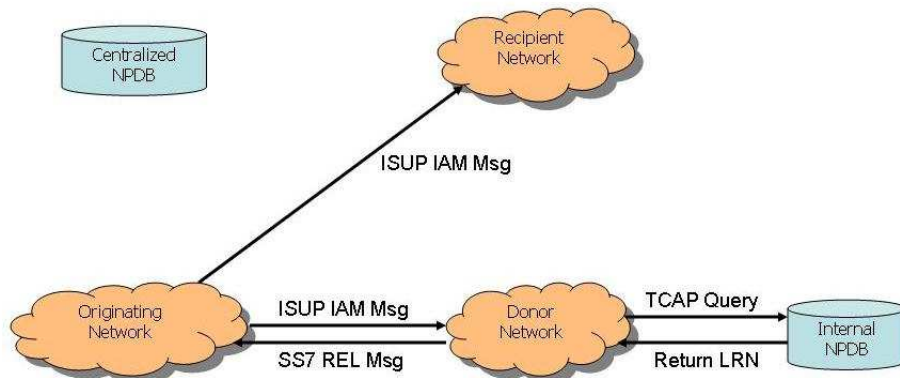

Figure 4: Call Dropback

2.2.2.3 Query on Release (QoR)

Fig. 5 shows the delivering steps in QoR scheme. The Originating Network generates a call to #B, and routes it to the Donor Network by assuming it were not ported yet. After detecting that #B has been ported out, Donor Network informs Originating Network that #B is no longer subscribed, and sends SS7 REL messages back to release the circuit. Then the Originating Network sends TCAP messages to query Centralized NPDB, and the Centralized NPDB responds with the routing number of #B. By learning routing information from the NPDB, the Originating Network forwards the call to the Recipient Network where #B stays.

2.2.2.4 All Call Query (ACQ)

Fig. 6 shows the fourth routing scheme. In ACQ scheme, both Donor Network and Internal NPDB are not involved, but Centralized NPDB is used instead. Therefore, when the Originating Network generates a call to #B, it will send a TCAP message to the

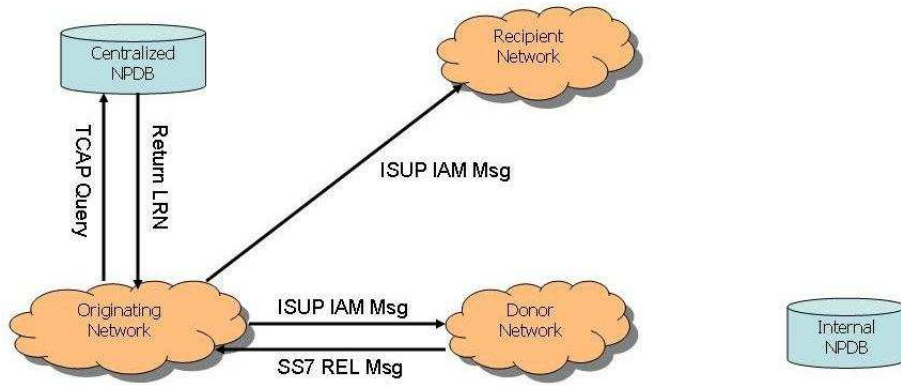

Figure 5: Query on Release

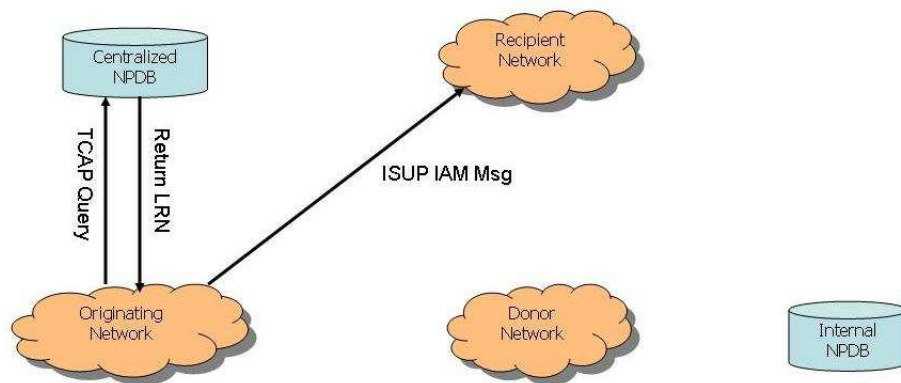

Figure 6: All Call Query

Centralized NPDB to retrieve the routing information associated with the dialed number #B, and then the Originating Network route the call to the Recipient Network directly. We can see that ACQ scheme doesn't check if #B is ported or not, but just send query to Centralized NPDB where contains the routing information for all numbers. This might cause a high traffic on the links between Originating Network and Centralized NPDB.

2.2.3 Qualitative Comparison

In last section, we have introduced four different routing schemes for number portability, but what are their benefits and drawbacks respectively? Next we will briefly compare those four schemes from three different aspects.

- Facilities cost

Initiating a call requires a series of facilities to be prepared simultaneity both in trunk network and SS7 network. For example, holding a call segment would reserve trunks and circuits as well as multiple switches resources. From the routing schemes we introduced above, except for the ACQ scheme, the other three schemes all have to set up two call segments, and for QoR and Dropback schemes, the call segment between Originating Network and Donor Network is temporary, while in OR scheme, the circuits have to be reserved all the time, until the call is routed to the Recipient Network. However, ACQ scheme doesn't involve the Donor network, so it only initiates one call segment from Originating Network to Recipient Network directly after fetching routing information of ported number from Centralized NPDB. Therefore, ACQ is the most efficient scheme if we consider the expense of

transmission facilities, and OR is the most expensive one.

- Sustainability

Number portability is an developing technology, we can expect more and more subscribers would like to choose this service in the coming future in countries all over the world, so which scheme will be a better long-term solution? We already know that OR and Dropback schemes both use Internal NPDB as the storage for routing information of numbers ported from Donor Network, so as more numbers are ported out from Donor Network, the traffic to the Internal NPDB would be significantly increased, which will cause much more delay in that scheme. Compared to the OR and Dropback schemes, QoR and ACQ schemes both use Centralized NPDB instead. As a third-party provided service, "Centralized NPDB contains the ported number information from multiple network" [10], so it would be keeping updated when a new number is ported. In this way, QoR and ACQ have better Sustainability than the other two schemes.

- Performance impacts

Currently, most comparisons about the four schemes are from a very high level like the cost or efficiency as we discussed above. However, the performance impact is an important consideration for routing perspective. Therefore, in our work, we would take packet delay as the main factor. Packet link delay consists four essential parts [15]:processing delay, transmission delay, propagation delay and queueing delay, and Queueing delay is the dominant of the four. The arrival rate of calls

and processing rates at the facilities will directly affect the queueing delay, and the ratio of choosing number portability is another important factor to impact the performance of each scheme. Therefore, in next chapter, we would build a model for each routing scheme and simulate the traffic flow under multiple situations, and find out the most stable and efficient routing scheme.

CHAPTER 3

MODELING

In our work, all simulations were processed by using CSIM, a toolkit for traffic modeling in computer or telecommunication networks. Thus, in this chapter, we will present how the models are built up within CSIM environment and how the parameters are chosen.

3.1 Routing Models

As we mentioned earlier, SS7 supports message exchanging and routing functionalities in telecommunication networks, so to compare the performance impact within each routing scheme, we only consider the call processing in SS7 network. Because number portability occurs among at least two telephone network operators, so the call routes of inter-networks are given higher priority when we build the model.

Before drawing models from the routing models, we first comprehend the details about the processes in local number portability within the multiple provider environment, from the SS7 perspective. Generally, the originating network, donor network and recipient network belong to disparate telephone companies, but the architecture inside are similar. Service Switching Points (SSPs), Signal Transfer Points (STPs), Service Control Points (SCPs) and Internal Number Portability Database (NPDB) are the basic components inside each network operator. In ACQ and QoR schemes, a third-party supported

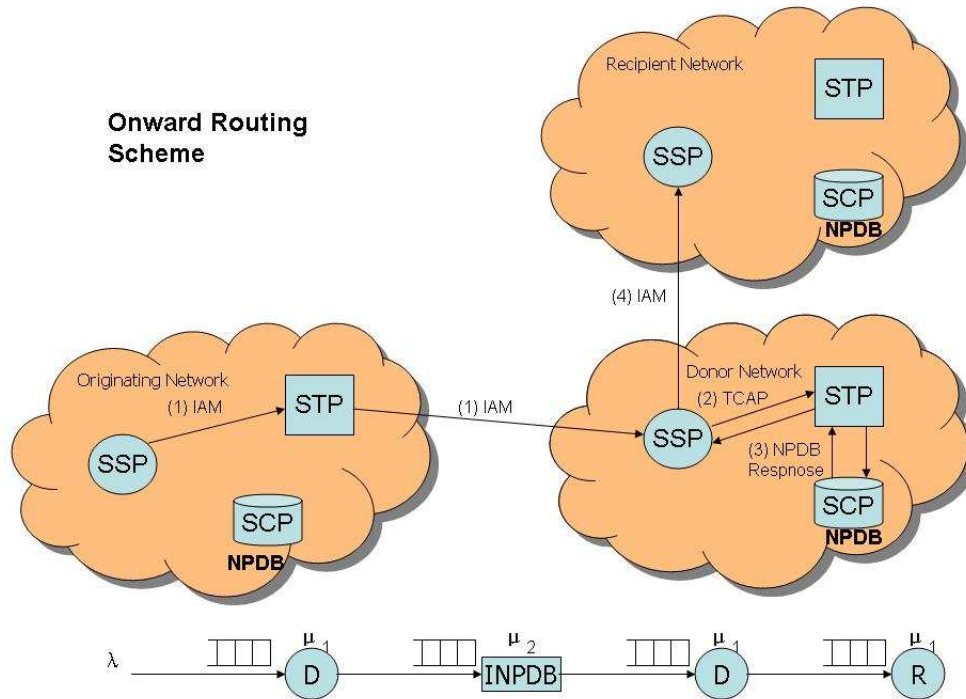

Figure 7: OR Scheme Modeling

NPDB, namely centralized NPDB, is applied instead of internal NPDB, and it's originating network who would send query to the centralized NPDB to get the LRN for ported numbers.

Take the Onward Routing scheme as an example, as presented in Fig. 7, we show how the scheme is simplify into a model for our simulation purpose. When a call is generated, the originating SSP generates an ISUP IAM message to the donor SSP to set up a call segment. Carrying information which includes the called party number and the routing label emphasizing OPC and DPC for the routing purpose, the IAM message might go through at least one STP to reach donor SSP. Then the donor SSP will first check

whether the called party directory number is in the portable domain [13], if so, the donor SSP will generate an SS7 TCAP message to the internal NPDB (SCP) at donor network. The NPDB responds with the LRN of called party number back to the donor SSP. With the updated routing information (LRN), the call is forwarded to recipient network. In other words, the donor SSP generates an ISUP IAM message to recipient SSP directly or through at least one STP, and the call is completed.

STPs' primacy task is routing the message to its destination, while SSP and SCP are the signaling points where the data transaction mainly take place. Therefore, we can model the scheme by ignoring the STPs during delivering messages, and only take SSP of each network as the main facility. In the above example, we only study the data transaction at originating SSP, donor SSP and recipient SSP within each network provider respectively, and model each network as a facility. The internal NPDB is another facility requiring transaction, which occurs at the SCP. Thus we model the donor SCP as Internal NPDB. Similarly, we can model the other three schemes in the same way.

Fig. 8 presents the models for the four number portability routing schemes. The circles marked by "D", "O", "R" represent Donor Network, Originating Network and Recipient Network respectively. The rectangles with tag "INPDB" and "CNPDB" mean Internal NPDB and Centralized NPDB respectively. Within each scheme model, λ means the arrival rate of calls, while μ_1 and μ_2 refer to the service rate at network operators and NPDBs.

Whenever a call is generated at originating network, an ISUP IAM is triggered at originating SSP. Thus, the inter-arrival of SS7 messages follow the same process as

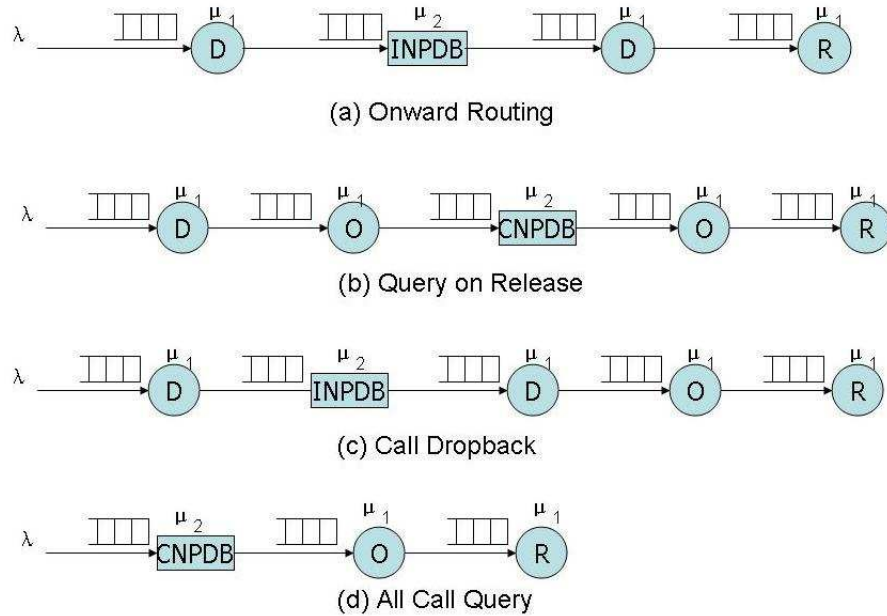

Figure 8: Modeling of Four Routing Schemes

telephone calls, which is assumed to be Poisson process. That is to say, in our model, λ also follows the Poisson process. To analysis the delay, we use M/M/1 queueing model at each facility of the model, which means the service time at each facility (μ_1 or μ_2) is constant exponential distributed. In addition, we assume that the call arrivals are infinite, and ignore the packet retransmission or blocking at any facility. Therefore, in Fig. 8 presents a queue at each facility due to the queueing delay. Because every generation of SS7 message is triggered by the arrival of the former message or call at the facility, the model for each scheme could be considered as a tandem queueing system [16].

3.2 CSIM Environment

Our goal is to find out the performance impact on delay due to number portability under different routing schemes, and this requires estimates of time in a system. CSIM provides such an environment for researchers to construct models, simulate the traffic flow's behavior, estimate the processing time in the system, and analyze the statistic characters of the performance.

As described in CSIM20 documents [1], a CSIM program is written in C codes which imports a CSIM simulation package, and it is able to mimic a system with discrete-event. CSIM has its own library to define its specific objects and methods, so that we can easily construct the facilities and create multiple processes to simulate the behavior of the system.

In modern telephone networks, the traffic is mainly calls in the trunk network or SS7 message flows triggered by call arrivals in the signaling network. Thus, every call can be considered as an individual process in CSIM program. There are four states [1] for a process in CSIM, and they are "create", "execute", "hold", and "wait". Fig. 9 shows how a process changes its states. Usually, when a process is created, it can be directly executed next, or hold for some simulation time, or wait for another event to occur. In other words, state "hold" gives the simulate time for the process to stay on, whereas the state "wait" means the process is waiting for some other event to occur before it move to the next state.

Our model focuses on the SS7 network, so the SS7 messages sent from originating network consist the traffic flow, or the processes of the system. As we have discussed in

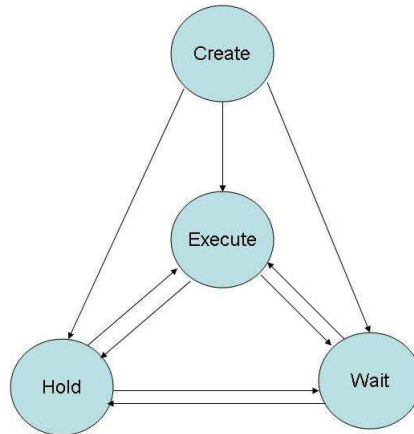

Figure 9: States of a CSIM Process

the last section, we simplified each network provider into a single SSP, and the NPDB as a SCP. These signaling points are modeled as facilities [1] in our CSIM program. Because of the data transaction occurring at either the network or NPDB, it needs to reserve the facility, takes some time to finish the "transaction" where the "hold" function is applied, and then release that facility. To use the M/M/1 queueing modeling, we give the parameter of "hold" function as the mean value of an exponential distribution. On the other hand, the inter arrival time between any two customers (SS7 packages) is given as the mean of an exponential distribution to represent Poisson process as well.

Signaling links were not treated as facilities in our model. There are two reasons. First, unlike trunks in the circuit-switch network, signaling links are only taken during transferring data but not the whole call. Secondly, based on our assumption, any two facilities are directly connected between two SSPs or one SSP and one SCP without going through STPs. Further more, the link set between any two SPs contains at most 16

signaling links, so the chance for queueing at the link set is very small. Again, we just simply take the link delay as an exponential distribution, and give the mean value as the parameter for the "hold" function used to represent the link delay. In the next section, we will present how we chose the value of parameters for our model.

3.3 Parameters

There are six different parameters used in our simulation.

- Average arrival rate of incoming calls or messages (λ_{calls}): $\lambda_{calls} = \frac{1}{t_{calls}}$, where t_{calls} is the average inter-arrival time of incoming calls/messages
- Average service rate at a network operator ($\mu_{netServ}$): $\mu_{netServ} = \frac{1}{t_{netServ}}$, where $t_{netServ}$ is the average service time at the links to a network operator.
- Average processing rate at the NPDB (μ_{dbServ}): $\mu_{dbServ} = \frac{1}{t_{dbServ}}$, where t_{dbServ} is the average processing time at the links to NPDB.
- Average external link delay (τ_{exLink}): here the external link delay refers the delay on the links outside of the network operators, i.e. from the donor network to the recipient network or from the originating network to the Centralized NPDB.
- Average internal link delay (τ_{inLink}): here the internal link delay refers the delay on the links inside of the network operators, i.e. from the donor network to the Internal NPDB.
- The percentage of users who choose number portability (Ported Rate: κ): Other than

various delay we have listed above, this is another important parameter which might affect the performance. Higher percentage of ported numbers represents more traffic arriving at the specific facilities, i.e. the Internal NPDB.

Table 1: Parameter – Notations

Parameter	Notation
Average arrival rate of incoming calls or messages	$\lambda_{calls} = \frac{1}{t_{calls}}$
Average service rate at a network operator	$\mu_{netServ} = \frac{1}{t_{netServ}}$
Average processing rate at the NPDB	$\mu_{dbServ} = \frac{1}{t_{dbServ}}$
Average external link delay	τ_{exLink}
Average internal link delay	τ_{inLink}
Ported Rate	κ

Our thesis work emphasizes on the packet delay in the whole routing schemes, and it consists of four parts[8]: processing delay (τ_{proc}), transmission delay (τ_{trans}), propagation delay (τ_{prop}) and queueing delay ($\tau_{queueing}$). Impacted by the arrival rate and the link service rate, Queueing delay is the most dominant factor to the packet delay. However, the other three parts of packet delay depend on either the bandwidth of the signaling links or the link distance, so their value is more deterministic.

We have know that the common signaling link bandwidth is 56kbps, and the average packet size for SS7 messages (i.e. ISUP IAM, ISUP REL or TCAP messages) is

40 bytes (320 bits) [15]. Therefore, we can get the value for the deterministic delay from following formulas [15]:

(1) τ_{proc} refers the time a router needs to process a packet header.

$$(2) \tau_{trans} = \frac{k(bit) \times 1000}{c(bit/sec)} = \frac{320 \times 1000}{56000} = 5.71 \text{ millisecc}$$

$$(3) \tau_{prop} = \frac{distance(km) \times 1000 \times 1000}{speed(m/sec)} = \frac{1500 \times 1000 \times 1000}{2 \times 10^8} = 7.5 \text{ millisecc. Here we only}$$

shows an example to see how to calculate the propagation delay. The exact value is based on the distance of signaling links.

Based on a conversation with someone [18] who is familiar with the realistic parameter values, we learned that the average one-way external link delay (τ_{exLink}), is typically in the order of 50 millisecc, whereas the one-way internal link delay (τ_{inLink}) is only about 5 millisecc. The average service time at network operators are around 5 millisecc (200 calls/sec), where the one at the NPDB is only around 1 millisecc (1000 calls/sec). This information gives us a perspective on the service rates and parameter values to consider in our study.

Table. 2 - Table. 4 list the values we have chosen for λ_{calls} , μ_{dbServ} , $\mu_{netServ}$, respectively. For the ported rate, we vary this rate from 5% to 95%, in 5% interval.

Table 2: Parameter – λ_{calls}

λ_{calls} (calls/sec)	20	50	100	150
$\frac{1}{\lambda_{calls}}$ (ms)	50	20	10	6.67

We divided the packet delay in our model into two parts: link delay (τ_{exLink} and τ_{inLink}) and queueing delay ($\tau_{queueing}$). We combined the three deterministic delay factors

Table 3: Parameter – μ_{dbServ}

μ_{dbServ} (calls/sec)	200	1000
$\frac{1}{\mu_{dbServ}}$ (ms)	5	1

Table 4: Parameter – $\mu_{netServ}$

$\mu_{netServ}$ (calls/sec)	75	100	150	200
$\frac{1}{\mu_{netServ}}$ (ms)	13.3	10	6.67	5

into the link delay, in other words, $\tau_{link} = \tau_{proc} + \tau_{trans} + \tau_{prop}$. The queueing delay $\tau_{queueing} = \frac{1}{\mu_{serv} - \lambda_{msg}}$. Assume the total time of routing a call to a ported number is τ_{tot} , then $\tau_{tot} = \sum_{i=1}^n \tau_{link} + \sum_{j=1}^m \tau_{queueing}$, where m and n present the number of facilities and links the message have gone through respectively.

In the next chapter, we will discuss the simulation scenarios based on those parameters.

CHAPTER 4

METHODS AND RESULTS

Packet delay might be affected by various factors, and as we listed in the previous chapter, all six parameters are possible reasons affecting the routing performance of each scheme. Our performance on post-dial call setup delay is conducted by considering the impact due to the percentage of numbers ported (κ). While in a realistic environment, it is unlikely that this rate will be beyond 25% to 30%, we were interested in understanding the pattern of behavior if the ported number becomes very high. In our study, we assume all arrival rates are Poisson and the service time at different facilities is exponentially distributed. On the other hand, we assumed the link delay was exponentially distributed, but later on, we assume it's uniformly distributed, because the propagation delay is the dominant factor and it depends on the distance between two networks. Here we only discuss the pattern of behavior with uniformly distributed link delay. Appendix A gives the result of comparisons of link delay under these two different distributions.

In this chapter, we will present our simulation methods in the first section and show the result in the rest of sections.

4.1 Scenario Design

Our goal is to compare the four schemes' behaviors due to various factors like arrival rate, ported rate, or service rate. Thus, two tasks need to be done, which are

scenario design and case study.

In the last chapter, we have discussed the average service rate and link delay in telephone network. In order to study the pattern of behavior when ported rate is increasing, we vary κ from 5% to 95%, and take this scenario as a reference point. Compared with the reference point, we discuss two kinds of scenarios by varying one of the main parameters ($\lambda_{calls}, \mu_{dbServ}, \mu_{netServ}$) at a time.

For each situation, we collected data with five different seeds, and in the graphs, we plot the 95% confidence interval. As it may be noted, in some cases, the width of the interval is small while for others this is large; this is dictated by the actual number of samples that affect a situation for a particular when the total calls generated is fixed.

4.1.1 Reference Point

As a reference point scenario, the parameter values are given in Table. 5.

Table 5: Reference Point Scenario Parameters

λ_{calls}	$\frac{1}{\lambda_{calls}}$	μ_{dbServ}	$\frac{1}{\mu_{dbServ}}$	$\mu_{netServ}$	$\frac{1}{\mu_{netServ}}$
50 (calls/sec)	20(ms)	1000(calls/sec)	1(ms)	200(calls/sec)	5(ms)

4.1.2 Scenario One: Adjusting the Service Rate

The first scenario based on the reference point we consider is adjusting the service rate at different facilities (NPDB or networks). In other words, we want to understand how the utilization at a specific facility will impact the performance of each routing scheme.

Since NPDB and the networks are different types of components in the scheme, we consider two different case studies.

Case I: Adjusting Service Rate in the NPDB

Table. 6 summarizes the first case study in Scenario One. We reduce the service rate at NPDB from 1000calls/sec to 200calls/sec, whereas other parameters keep the same values as they are in the reference point.

Table 6: Scenario One - Case I - Parameter Values

λ_{calls} (calls/sec)	Link Delay (ms)		Service Rate (calls/sec)	
	τ_{exLink}	τ_{inLink}	$\mu_{netServ}$	μ_{dbServ}
50	50	5	200	1000
				200

Case II: Adjusting Network Service Rate

The next case is how those four schemes' performances will be affected if the $\mu_{netServ}$ changes. Except for the ACQ model, which does not include the Donor Network, the other three models all involve three types of networks. But when tracking the traffic flow in each model, we found that the traffic goes through some certain network more than once. That is, each model actually involves different number of facilities. Thus, it's necessary to discuss the performance impact due to a specific $\mu_{netServ}$ changing. We specifically modified one provider's service rate at a time (out of three: DN, ON, RN) , and compare the performance of four schemes.

Table. 7 summarizes the second case study in Scenario One. We reduce the service rate at one specific network ($\mu_{xNetServ}$, i.e. x represents "D" when we care about Donor Network's performance impact) at a time, whereas other parameters keep the same values as they are in the reference point.

Table 7: Scenario One - Case II - Parameters Values

λ_{calls} (calls/sec)	Link Delay (ms)		Service Rate (calls/sec)		
	τ_{exLink}	τ_{inLink}	μ_{dbServ}	$\mu_{netServ}$	$\mu_{xNetServ}$
50	50	5	1000	200	200
					150
					100
					75

4.1.3 Scenario Two: Adjusting the Arrival Rate

If all service rates at the facilities keep fixed, including both NPDBs and network providers, then the arrival rate of incoming calls will affect the queueing delay of packets at each facility. In this case, our goal is to test the stability of each scheme when the system has high traffic load. At the same time, we also adjusted the NPDB service rate to see how increment delay was affected when arrival rate changed. Table. 8 summarizes the second case study in Scenario One. We changed the arrival rate, whereas other parameters keep the same values as they are in the reference point.

Table 8: Scenario Two - Parameter Values

λ_{calls} (calls/sec)	Link Delay (ms)		Service Rate (calls/sec)	
	τ_{exLink}	τ_{inLink}	$\mu_{netServ}$	μ_{dbServ}
150	50	5	200	200
100				
50				
20				

4.2 Simulation Methods and Tools

In this section, we will explain how we collect data from CSIM simulations for the the scenarios above.

4.2.1 A General Round

Generally, our simulation will take arrival rate, service rate and ported rate as variables in our CSIM program for each routing scheme model. We generated 100000 packets when running the program every time, and it will return the mean simulation time, which is also the average time needed to route a call to a ported number based on our model. Increasing the ported rate from 0.05 to 0.95 by every 5%, we repeated the simulation nineteen times, and we call it as one round simulation.

4.2.2 Seed

A seed [16] is an integer which is used to generate a series of pseudo random numbers. By setting a different seed, we can get a different result after one round of simulation is done. If we run the program without setting a seed, then every time when generating random numbers, the program will return the exactly same result.

We gave five different seeds in order to obtain different results while running multiple rounds of the simulation with the same values of variables. Therefore, under the same ported rate and other variables, we have five different results. For example, we ran five rounds of simulations for ACQ scheme with parameters: $\mu_{netServ} = 200(\text{calls}/\text{sec})$, $\mu_{dbServ} = 1000(\text{calls}/\text{sec})$, $\kappa = 0.05$ and $\lambda_{calls} = 200(\text{pkg}/\text{sec})$. Each round was implemented under different seed: 5, 17, 31, 47, 61, which we picked randomly. In this way, the five results are shown in Table. 9:

Table 9: Results Obtained Based on Various Seeds

Seeds	Total Delay (ms)
5	162.964431
17	162.964431
31	162.807604
47	162.724425
61	162.493808

4.2.3 Confidential Interval

Using multiple seeds is able to allow us obtain different results, and most of them are in an acceptable range. Because the both call arrival and the service rate are in exponential distribution, we take the mean value of the total routing delay, which is also the result returned by CSIM program. However, one average delay is only based on the sequence of random numbers generated with one seed, and we gave five different seeds so that we can obtain the average delay of the five.

Here we use a method to estimate an interval, which is so-called confidential interval [16]. Confidential interval will show a reliable interval estimation for a parameter. Assuming we have a fixed size of samples:

$$X_i, i = 1, 2, 3, \dots, n.$$

In our case, we take $n = 5$, and each X_i was one average delay returned by one round of simulation. Thus the confidence interval for this parameter is given by the following expression [16]:

$$\bar{X}(n) \pm t_{n-1, \alpha/2} \times \frac{S(n)}{\sqrt{n}}$$

where the mean of X_i is

$$\bar{X}(n) = \frac{\sum_{i=1}^n X_i}{n},$$

and the variance of X_i is

$$\frac{1}{n-1} \times \sum_{i=1}^n (X_i - \bar{X}(n))^2.$$

In addition to those, here $t_{n-1,\alpha/2}$ has a Student's t distribution [17]. Therefore, the expression for shows an $100(1 - \alpha)\%$ confidence interval with $n - 1$ degree of freedom. The value of $t_{n-1,\alpha/2}$ can be looked up from Table. 10[17]:

Table 10: Student-t Distribution Table

$n - 1 \setminus \frac{\alpha}{2}$	0.05	0.025	0.01	0.005
2	2.920	4.303	6.965	9.925
3	2.353	3.182	4.541	5.841
4	2.132	2.776	3.747	4.604
9	1.833	2.262	2.821	3.250

In our work, since we only used 5 seeds to generate random numbers in CSIM, so $n = 5$. Then for 90% confidence interval, we obtain $t_{4,0.05} = 2.132$ from Table. 10.

So the confidence interval of the total delay in Table. 9 is $[162.7940 - 0.1899, 162.7940 + 0.1899] = [162.6041, 162.9839]$, so the value 162.493808 corresponding to seed 62 is not considered.

Therefore, by finding out the confidence interval of the total routing delay, we are able to further discuss the performance of each routing scheme under different scenarios.

4.2.4 Plots

We ran the simulations in CSIM environment, and organized the results of each case into a 19×5 matrix by running a simple shell scripts, the matrix then was used as an input to a MATLAB program, which returned the confidence interval of each result for its

related ported rate. We plotted each confidence interval by using errorbar [18], so that any two confidence intervals have overlaps can be considered as equal. We will show details about this in the next section.

4.3 Results and Analysis

In this section, we will present our results based on the scenarios and methods we have introduced.

4.3.1 Reference Point Scenario

In the reference point scenario, we mainly study the pattern of behavior of each scheme when ported rate rise up. The following scenario study is based on this by adjusting other parameter's value.

Fig. 10 presents the pattern of behavior of four schemes respectively, when ported rate increases. According to the this figure, we can see that the total routing delay is linear related to the ported rate. the ACQ scheme is least impacted by the ported rate, while the total routing delays in different schemes have various specific relative increments as ported rate goes up.

The percentage of calls to ported numbers requiring support from other networks (depending on the routing type) will increase because of the ported rate increases. Thus, the queueing delay at related facilities will rise in general, assuming all other factors are being kept fixed (Table. 5). Recall that the routing mechanism of each scheme, in OR, QoR and CD schemes, the Donor Network works as a filter to sift the calls whose destination numbers have been ported out. However, the number of facilities which that

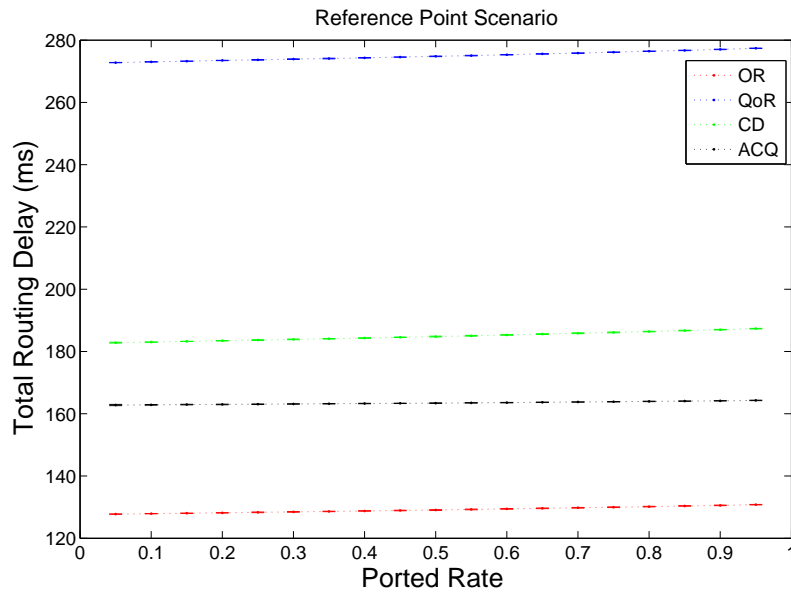

Figure 10: Reference Point Scenario

part of traffic should go through is different in each routing scheme. For example, in the OR scheme, the calls will continue to go through the Internal NPDB, and go back to the Donor Network, then be forwarded to the Recipient Network; thus, the total facilities visited are three. Similarly, there are four facilities involved in both the QoR and the CD schemes after the Donor Network finished checking task. On the other hand, ACQ scheme does not involve the Donor Network, but all incoming calls are sent to Centralized NPDB from the very beginning, and then back to Originating Network. After that, there is only one more step to send the calls to the ported numbers that are currently held by the Recipient Network. Thus, with a higher ported rate, here is only one queueing where delay is increased in this scheme.

On the other hand, if comparing the total routing delay in four schemes at a specific ported rate, we can see big difference among four schemes. Fig. 10 shows that the routing process takes more delay in the QoR scheme than the other three, and takes least delay in OR scheme, the delay in the ACQ scheme is more than that in the OR scheme. According to our assumption, the external link delay is much more than the internal link delay, thus the scheme involves more external links will result in more total routing delay. For example, the ACQ schemes doesn't have internal link delay but it has three external links, so the average total link delay will be 150ms. However, OR scheme only has two external link delay (from ON to DN, and from DN to RN), and two internal links (DN to Internal NPDB, Internal NPDB to DN), so total link delay is around 110ms. The difference of routing delays between these two scheme is around 40ms, which is also reflected from Fig. 10. Due to this reason, we reduce external link delay down to 25ms, in order to have a better comparison about the pattern of behavior of each scheme. This case study will be discussed in appendix B.

The reference point scenario gives an intuitive understanding on the processing involved with the four schemes. However, the actual behavior is better understood as we consider specific parameter values.

4.3.2 Scenario One: Adjusting the Service Rate

In this section, we will discuss the results of two case studies within scenario one.

Case I: Adjusting Service Rate in the NPDB

Fig. 11 displays the total routing delay within each scheme under different NPDB service rate, when the service rate decreases, the utilization of NPDB is higher. Recalling the routing mechanism of each scheme, unlike in the other three schemes, within ACQ scheme, all calls generated from ON are sent to NPDB, no matter the called numbers are ported or not. Therefore, even when the ported rate is low, the queuing delay at NPDB within the ACQ scheme increases much more than it is in the other three schemes.

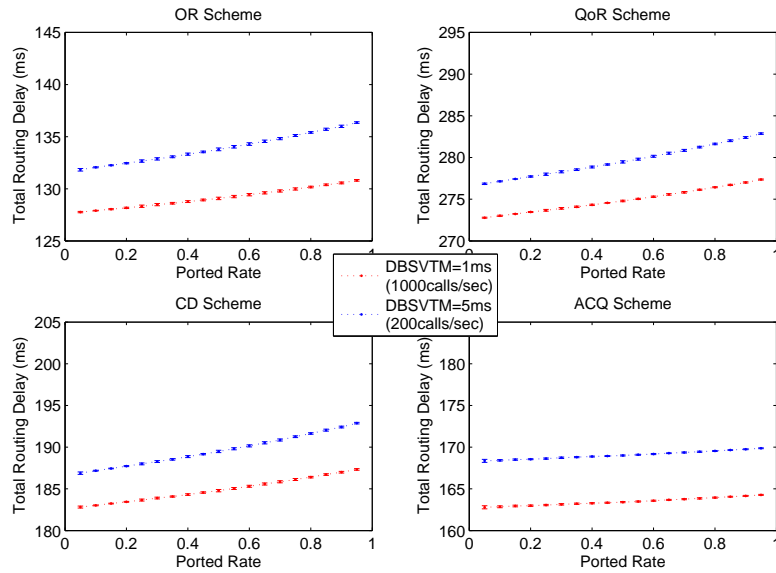

Figure 11: Case I – Behavior of Four Schemes When Service Rate is Changed at NPDB

In order to understand how NPDB service rate changing affects the performance of a routing scheme, we studied the relative growth rate of the total routing delay after NPDB service rate reduces. We define $k_x = \frac{\tau_{totAfter} - \tau_{totBefore}}{\tau_{totBefore}}$ as the relative growth rate of total routing delay in scheme x .

Fig. 12 compares the relative growth rate of total routing delay within four schemes. If we look at Fig. 11, the absolute value of increasing delay is similar among four schemes. However, based on the discussion on the reference point, we know that with a specific ported rate, the total routing delay is most in the QoR scheme, and the second most in the CD scheme, and so on. Therefore, as reflected from Fig. 12, the relative growth rate of total delay is the least in the QoR scheme. More specifically, it's the highest in the OR scheme when ported rate is getting higher. In this case study, we find that the change of NPDB service rate makes least relative impact on the QoR scheme, whereas the OR scheme will be most relatively affected when ported rate is high.

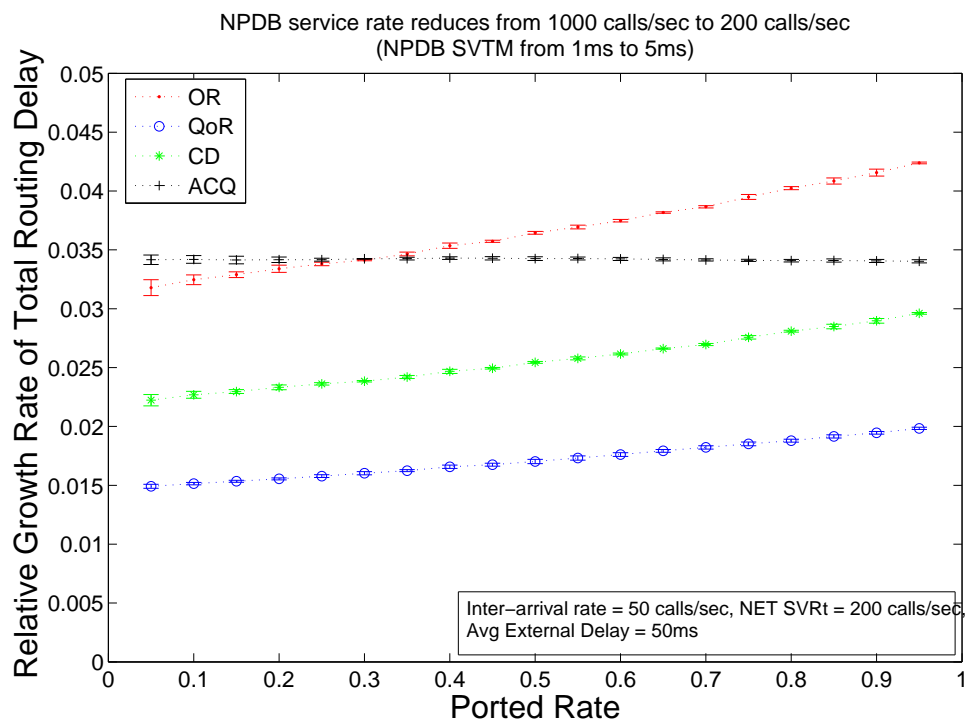

Figure 12: Case I – Relative Growth Rate of Total Routing Delay

Case II: Adjusting Network Service Rate

The second case we considered is how those four schemes' performance will be impacted if one out of the three networks (ON, DN and RN) has changed its service rate.

1. Donor Network (DN) changes service rate

In the ACQ scheme, Donor Network is not included, so it won't affect its performance. Thus Fig. 13 displays the total delays of the other three schemes under various Donor Network service rates, respectively. Recall the routing mechanisms of the OR scheme and the CD scheme, the traffic to ported numbers will go through Donor Network twice, especially when ported rate is getting higher, the traffic from Internal NPDB to the Donor Network will increase significantly, so that the queueing delay will rise up as well. Reflected from the patterns in Fig. 13, we can see that when Donor Network service rate is slower, namely with higher service time, the total routing delay is not linear proportional with ported rate within the OR scheme or the CD scheme. However, in the QoR scheme, since all traffic goes to Donor Network from Originating Network only once, so when Donor Network gets lower service rate, the total routing delay is linear proportional pattern respected with the ported rate.

Now we would like to know how does Donor Network would relatively affect those three routing schemes' performance, so we plot Fig. 14. Based on the delay patterns presented in Fig. 13, we picked the subcase where we reduce the DN service rate from 200 calls/sec to 100 calls/sec, namely increase the service mean time at the Donor Network from 5ms to 10ms, and then compare the relative growth rate of total routing delay. The red line represents the OR scheme, because it has the smallest total delay among the four

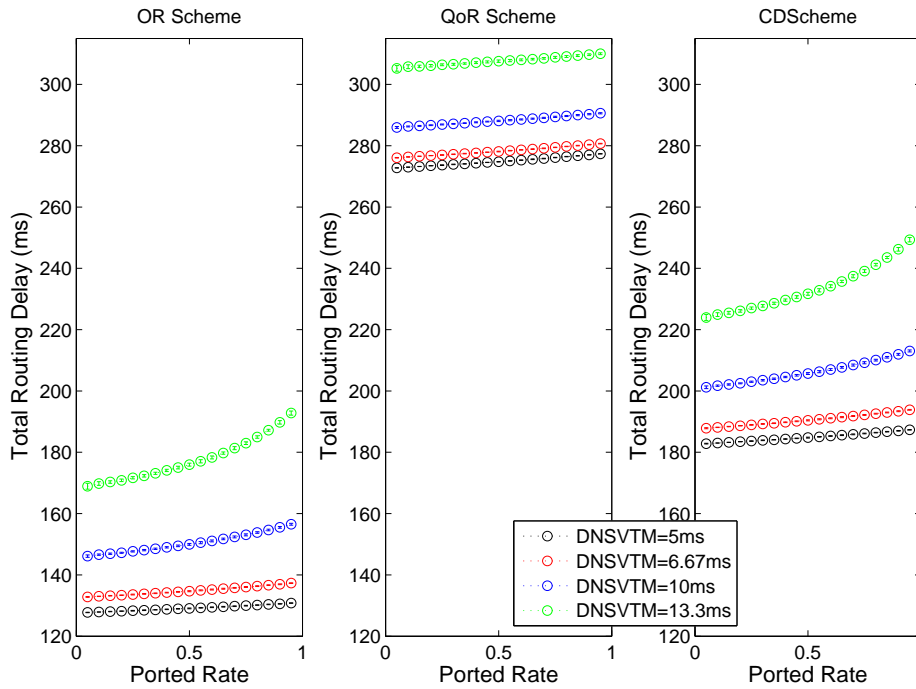

Figure 13: Case II (a-1) – Behavior Pattern When Reducing Service Rate at DN

schemes, according to the reference point, while the absolute increment is similar to the other two, the total routing delay in the Donor Network has the most relative growth rate. In other words, the Donor Network service rate affects the OR scheme most.

2. Originating Network service rate changes.

The second subcase is to study how ON's service rate would impact the routing performance for each scheme. Since in the OR scheme, after being generated from Originating Network, the traffic doesn't go through it again, so the ON's service rate won't make effect to the OR scheme. Thus, we plot the total routing delay under various ON service rate (service mean time at ON) for each of the other three scheme separately in

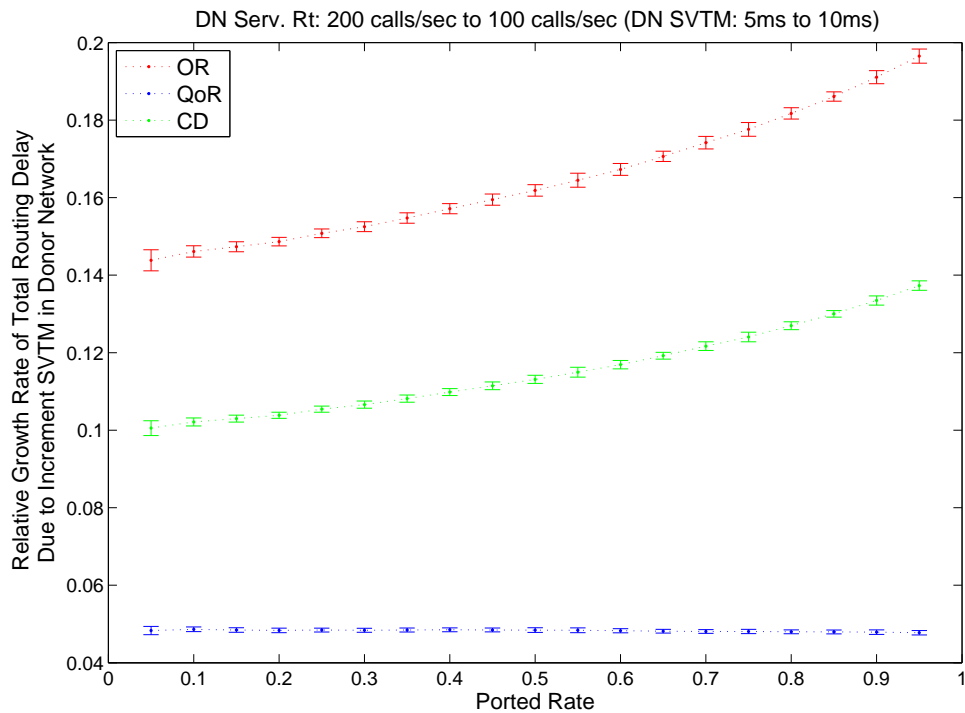

Figure 14: Case II (a-2) – Relative Growth Rate of Total Routing Delay Due to DN Changes Service Rate

Fig. 15.

As we discussed about the routing mechanism of the four schemes earlier, the traffic to ported numbers goes through the ON twice only within the QoR scheme, especially when ported rate is getting higher, the traffic will increase significantly. In the CD scheme and the ACQ scheme, the traffic to ported numbers goes through ON only once. In the CD scheme, only calls to the ported numbers are sent to the ON, whereas in the ACQ scheme, other calls will be sent to the ON together with these target calls. Therefore, if

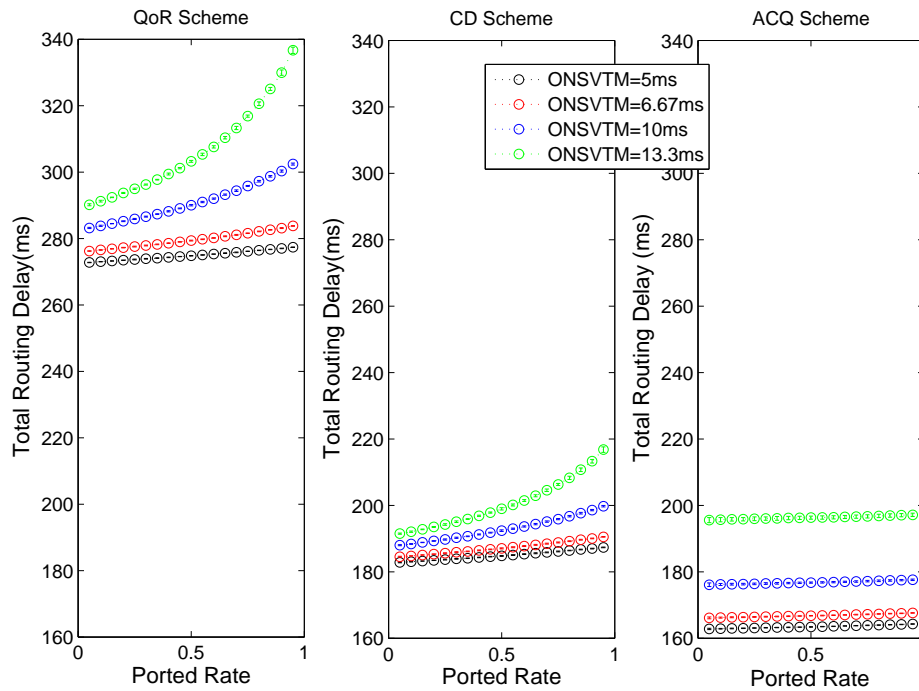

Figure 15: Case II (b-1) – Delay Pattern When Reducing Service Rate at ON

the ON service rate is reduced, the queuing delay at the ON in the CD scheme will increase according to the ported rate. However, in such case, the queuing delay at the ON in the ACQ scheme will rise up immediately when ported rate is low, and it's independent to the ported rate.

Fig. 15 well presents this result above. By giving the same scale for each scheme, we can see that when ported rate is high, with higher ON service time, the total routing delay increases much faster in the QoR scheme than it's in the CD scheme. On the other hand, the pattern of total delays are parallel relation among various ON service time.

Consider how the ON relatively impact each scheme, we plot the relative growth rate of total routing delay for the QoR, CD, and ACQ scheme in Fig. 16 with different increment in service mean time, respectively. For each increment, we can see that the CD scheme has least impact out of the three schemes. If we compare the other two (ACQ and QoR) schemes, their patterns cross each other at a higher ported rate, which are around 0.75, 0.85 and 0.91 when the increment is 1.67ms, 5ms and 8.3ms respectively. When the ported rate is higher than this, the QoR scheme will be more affected by the ON service rate than the ACQ scheme.

Therefore, without considering the OR scheme, the ON service rate has least relative impact on the CD scheme's performance, and when ported rate is low, the QoR and the CD present better than the ACQ scheme.

3. Recipient Network service rate changes.

The third subcase is to study how Recipient Network (RN) would impact the routing performance of each scheme. It's obviously that RN is the basic component for four schemes, so we want to see the total routing delay under various increment of RN service mean time. Fig. 17 present the pattern of routing delay for the four schemes. Because within each scheme, it's the same that only traffic sent to ported numbers are finally arrive at RN, the queueing delay at RN is not increasing linear proportionally to the ported rate. When ported rate is high, the more RN service time increases, the faster the queueing delay increases, and this turns out the total routing delay increases faster at a higher ported rate.

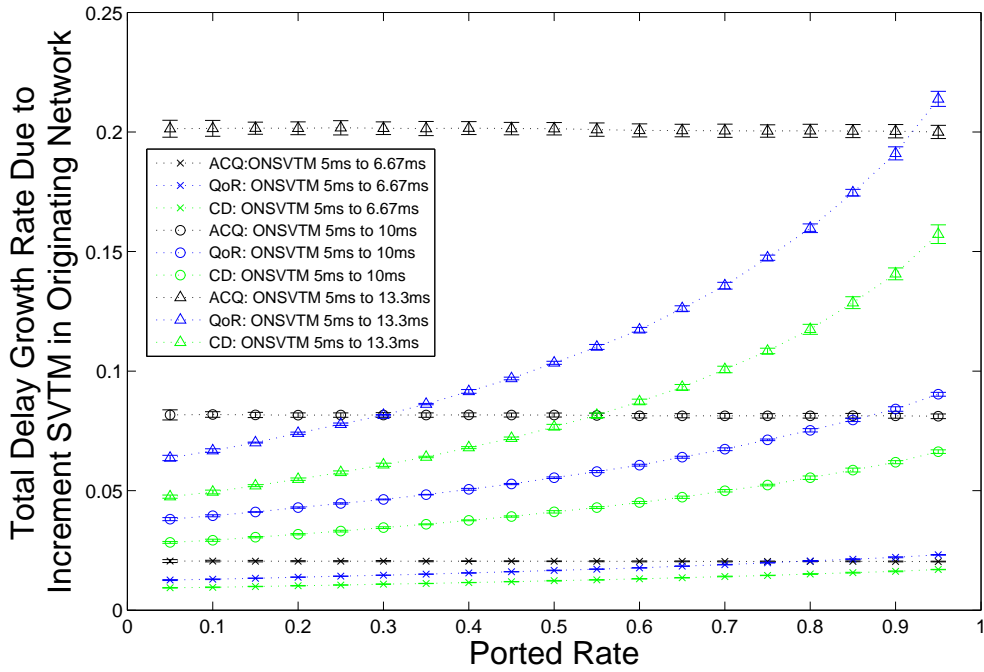

Figure 16: Case II (b-2) – Relative Growth Rate of Total Routing Delay Due to ON Changes Service Rate

Like the about two subcases of Case II, we also care about the relative impact on each scheme when RN service rate changes. Fig. 18 compares the relative growth rate of total routing delay for the four routing schemes with different increment in service mean time, respectively. Because the absolute increment of total delay depends on the increment of queueing delay at RN, which is not much different among four schemes, so the scheme with smaller total routing delay is more relatively impacted. In other word, the OR scheme is the most relatively affected by RN, and the QoR is the least relatively affected scheme.

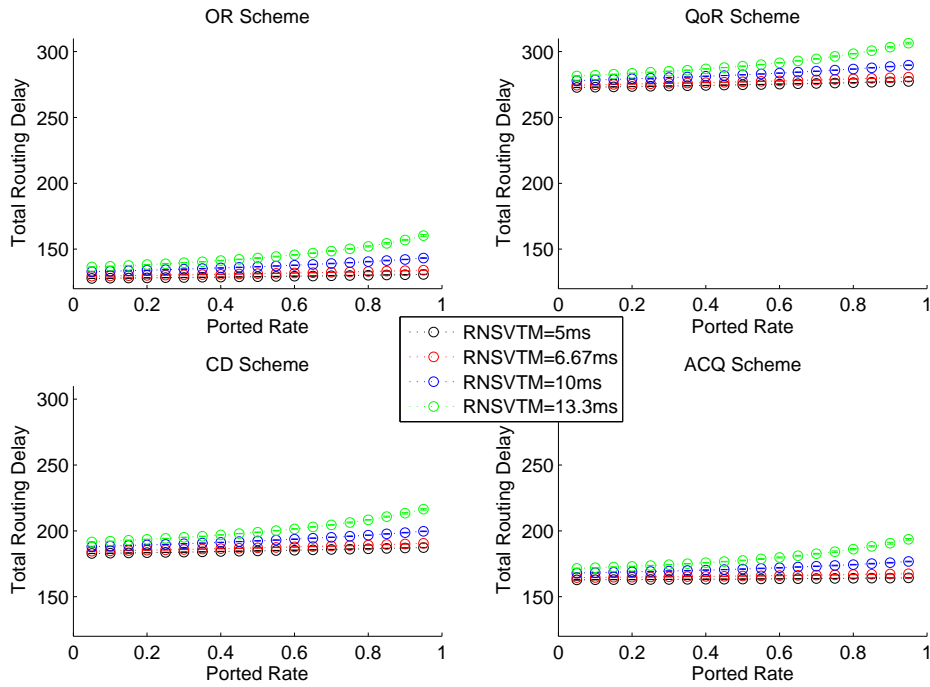

Figure 17: Case II (c-1) – Delay Pattern When Reducing Service Rate at RN

Conclusion from Case I and Case II

We have discussed the performance impact on each number portability routing scheme (OR, QoR, CD, ACQ) due to different facilities (NPDB, DN, ON, RN) from Case I and Case II studies. Here we are going to find out which facility is mostly relatively affect the routing scheme according to the reference point scenario. We pick subcases (Increasing $\mu_{xNetServ}$ from 5ms to 10ms) from Case II and compare them with the NPDB.

Fig. 19, Fig. 20, Fig. 21 and Fig. 22 display the relative growth rate of total routing delay due to an increment of the service time in one specific facility within the OR, QoR, CD, and ACQ schemes, respectively. We have already discussed the total routing delay

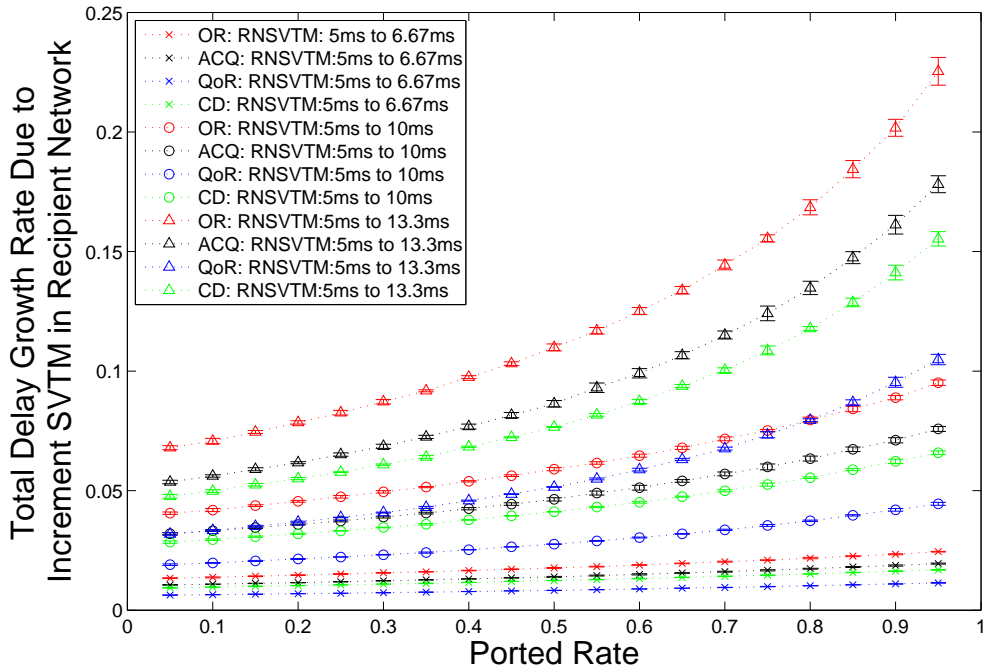

Figure 18: Case II (c-2) – Relative Growth Rate of Total Routing Delay Due to RN Changes Service Rate

under various service time at each facility in Case I and Case II. Therefore, when compare the relative growth rate, we can make following conclusion:

- Donor Network service rate makes most impact to the OR scheme, while the Originating Network doesn't affect it at all.
- When ported rate is low, the Donor Network service rate affects the QoR scheme most, and if the ported rate rise up, the Originating Network affects the QoR scheme most. The Centralized NPDB makes least impact to the QoR scheme.
- The Donor Network service rate affects the CD scheme most, while the Internal

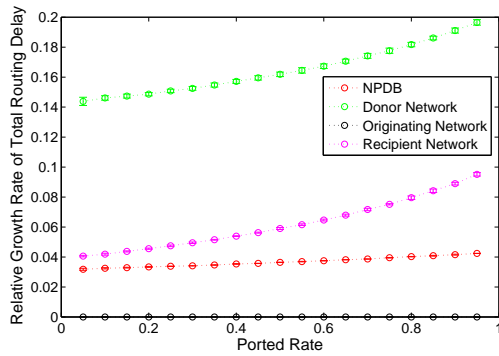

Figure 19: Performance Impact on Onward Routing Scheme Due to Increasing Service Time at Different Facilities

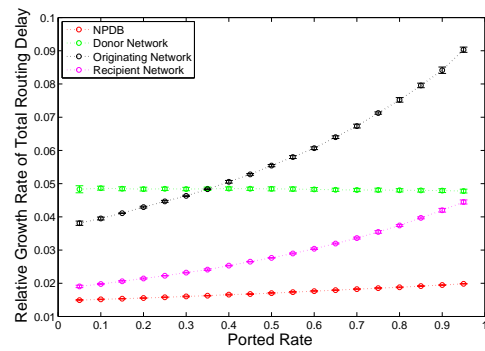

Figure 20: Performance Impact on Query Routing Scheme Due to Increasing Service Time at Different Facilities

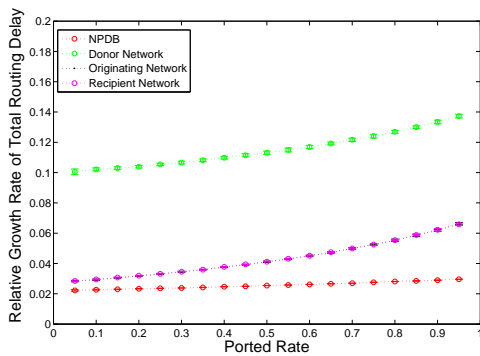

Figure 21: Performance Impact on Call Dropback Scheme Due to Increasing Service Time at Different Facilities

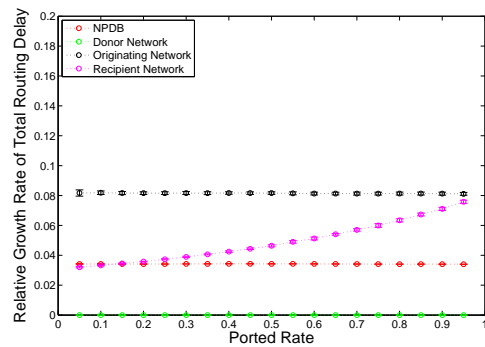

Figure 22: Performance Impact on All Call Query Scheme Due to Increasing Service Time at Different Facilities

NPDB makes least impact to the CD Scheme. The Originating Network and the Recipient Network service rates give the same impact to the CD scheme.

- The Originating Network service rate impacts the ACQ Scheme most, while the Donor Network doesn't impact it at all.

4.3.3 Scenario Two: Adjusting the Arrival Rate

In our model, each facility can be considered as an individual M/M/1 system separately, so the each queueing delay can be expressed as $\frac{1}{\mu-\lambda}$, and the expected number of customers in one facility is the ratio of arrival rate and service rate, namely $\rho = \frac{\lambda}{\mu}$. We have discussed the case when there is only one but not all facilities changed their service rate under the same call arrival rate. This scenario is to discuss the performance of four schemes under diverse call arrival rate.

Fig. 23 displays the comparisons among the four schemes when reducing the arrival rate (or increasing the arrival time) of incoming calls by different values. Although the growth rate is different in each scheme in Fig. 23, the relation between the patterns of four schemes is similar. The total delay is a summation of each individual delay in the model, including the queueing delays. Recall the routing mechanisms again, the traffic sent to ported numbers goes through five facilities in the QoR scheme and the CD scheme, while it only goes through three facilities in the ACQ scheme. In the OR scheme, the traffic have to pass four different facilities before it reach the ported numbers. Thus, under higher arrival rate, the number of customers at a facility increases, which results in a

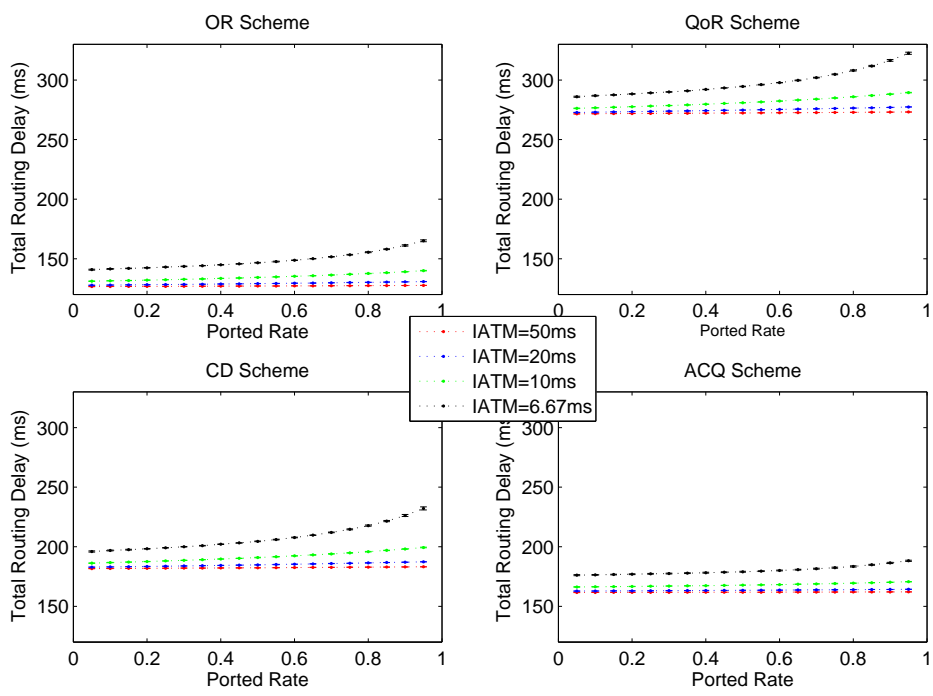

Figure 23: Delay Pattern When Reducing Arrival Rate of Incoming Calls

longer queueing delay at this facility. Therefore, a routing scheme involving more facilities during forwarding the calls to the ported rate will have a longer accumulated routing delay, especially when ported rate rises up. From Fig. 23, we find that at a higher ported rate, the total delay increases faster in the QoR scheme and the CD scheme under a higher arrival rate than the other two schemes, and the ACQ scheme presents the slowest growth rate in total delay when arrival rate is higher.

Therefore, in this scenario, we can conclude that with a higher load, the ACQ scheme performs a more stable behavior, and the QoR and the CD schemes are not well adjusted.

CHAPTER 5

SUMMARY

In this thesis, we have compared the performances of four routing schemes of number portability from the routing perspective by simulating in the CSIM environment. Currently most of comparisons about the four number portability routing schemes are from a very high level, including the facility costs and sustainability. As number portability is more and more popular all over the world, choosing a better scheme to provide efficient and stable performance is very important.

We focused on three tasks in this thesis to approach this goal. First, according to the routing mechanism, a simplified traffic model for each routing scheme was developed in CSIM based on [6]. We also discussed parameters which should be applied to the traffic model, and then determined a group of values for each parameter. In order to make the analysis not that completed, we developed the models based on M/M/1 queueing model, so that we are able to find out the queueing delay at each facility in the model, and finally got the total routing delay in the model. Secondly, we designed various scenarios for simulations, which mimic multiple cases in the real world. Of all parameters we presented, only service rate, arrival rate, and ported rate are defined as parameters case by case. To study the impacts due to each individual variable, we only changed values for one parameter at a time. Following this, we studied the simulation results by plotting it as confidence intervals. By comparing the relative growth rate of total routing delay in each

traffic model of the related routing scheme, the inferences can be concluded as follows from the floating delay's point of view: (1) All Call Query scheme provides more stable performance than others, especially when ported rate is high. (2) Keeping incoming calls in the same arrival rate, the service rate at NPDB affects All Call Query scheme more, especially when not many customers choose number portability. In other words, if the transaction at NPDB is improved, the performance of All Call Query scheme will show most obvious improvement. (3) Changes in Donor Network don't make any difference to All Call Query scheme, while changes in Originating Network don't make any impacts to Onward Routing scheme. (5) If all facilities are working normally, the arrival rate of incoming calls make least impacts on All Call Query scheme, comparing to the other three. (6) Generally, the Call Dropback scheme has similar delay floating as the Onward Routing scheme does most of the time, while sometimes it reflects similar performance as the Query on Release scheme.

To summarize our work in short words, there are several key points we got from the case studies:

- From the total routing delay's perspective, the OR scheme shows better performance, because it has less external links and less facilities.
- The ACQ scheme shows more stable performance to the ported rate, and its performance is not much affected by the system load.
- When ported rate is low, the QoR scheme is less relatively affected by its components' service rate.

CHAPTER 6

FUTURE WORK

Our current abstraction is derived from understanding the different components involved in the call setup path in a number portability environment. In this process, we made some simplified assumptions. In particular, we made a simplified abstraction for each scheme from a very complicated SS7 network architecture and found out several representative cases that can cover possible factors impacting the performance. In our future work, we plan to include more detail components in the model. Furthermore, our current study does not include any background traffic, nor does it include the presence of multiple originating networks trying to setup calls to different recipient networks, which may result in some cross traffic interactions. We plan to consider this in our future work.

APPENDIX A

VARIOUS LINK DELAY DISTRIBUTION TEST

During the simulation, we used to assume the link delay is exponentially distributed, and later on we found that the propagation delay, which is the dominant factor to the link delay, depends on the distance between two facilities in the routing scheme. As a result, we consider to give the link delay as uniform distribution.

However, how different is a exponentially distributed link delay impacts the routing performance from a uniformly distributed link delay does? We make a comparison for them in the reference point scenario.

Fig. 24 presents the performances of four schemes under the two link delay distributions. Here we don't unify the scale of the vertical axis for the four schemes, because the four schemes has much differences in the total routing delay due to multiple links and facilities where the traffic goes through, especially for the OR scheme and the QoR scheme.

There are two main difference we can observe from Fig. 24. First of all, being uniform distribution, the average total routing delay in each scheme increases more linear proportional to the ported rate. Second, the confidential interval of total routing delay under different ported rate is also more like a uniform distribution when the link delay is uniformly distributed.

However, being a exponential distribution, the average total routing delay doesn't

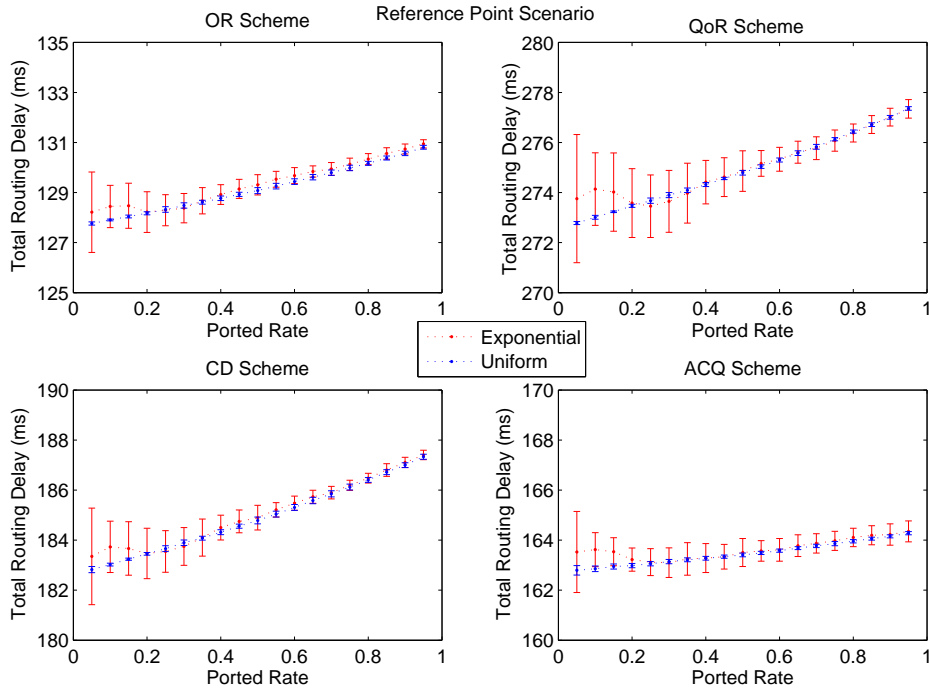

Figure 24: Performance Impact Due to Different Link Delay Distributions

follow a linear relation with the ported rate, especially under lower ported rate. Moreover, the confidence interval is bigger when the ported rate is low, and this is dictated by the actual number of samples that affect a situation for a particular when the total calls generated is fixed.

By comparing these two particular cases in the reference point scenario, we think that a uniformly distributed link delay is more reasonable for the simulations, because the dominant factor propagation delay is deterministic

APPENDIX B

VARIOUS EXTERNAL LINK DELAY TEST

In the reference point scenario, we gave the external link delay as 50ms and the internal link delay as 5ms, according to a realistic statistic. Based on this assumption, the scheme has more external links results in a much higher routing delay, and this can be clearly reflected by the gap between any two patterns in Fig. 10.

We are curious about a particular situation with a less external link delay, which is 25ms. In order to view the difference between these two situations, we compare the total routing delay under a very heavy load, which is 150 calls/sec (inter-arrival mean time = 6.67ms). Fig. 25 displays the total routing delays of four schemes under different external link delays. When the external link delay reduces, the gaps between any two delay patterns become smaller as well. Particularly, if we look at the delay patterns of the OR scheme and the ACQ scheme, they cross each other at 0.9 ported rate when the average external link delay is 25ms. This indicates that under a heavy load when generating calls, it's a trend that the ACQ scheme is better than the OR scheme when ported rate is high.

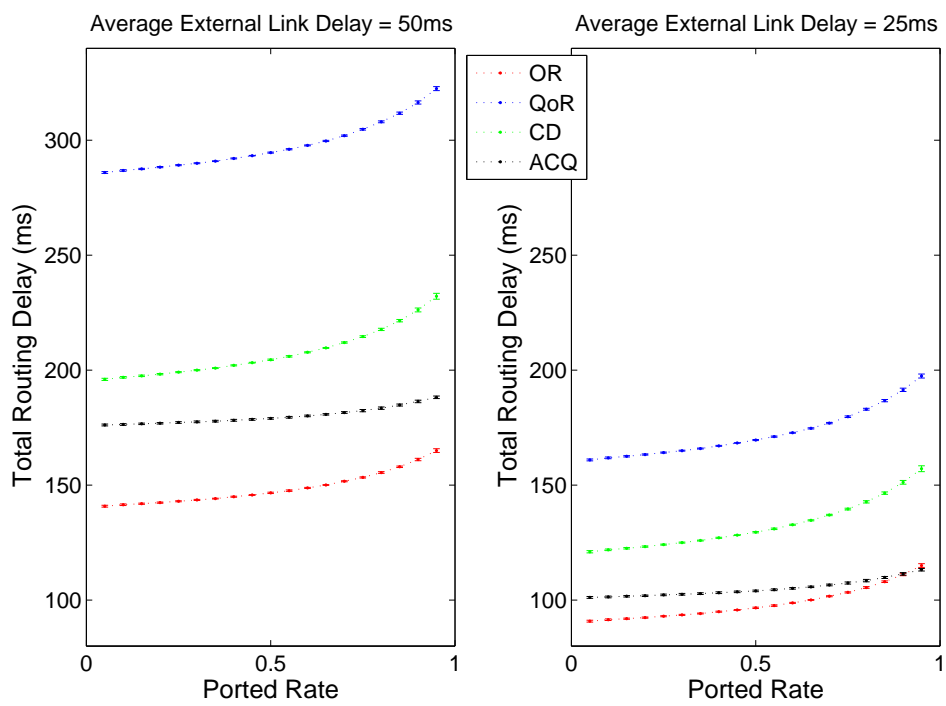

Figure 25: Performance Impact Due to Different External Link Delay

REFERENCE LIST

- [1] Getting Started: CSIM 20 Simulation Engine(C Version). http://www.mesquite.com/documentation/documents/CSIM20_Getting_Started-C.pdf.
- [2] Number Portability. http://www.sysmaster.com/brochures/number_portability.pdf. Sysmaster.
- [3] ITU-T Q702: Specifications of Signaling System NO.7 - Signaling DataLink. Tech. rep., International Telecommunication Union, October 1989.
- [4] FCC First report and order and future notice of proposed rulemaking, 1996.
- [5] Number portability -Capability set 2 requirements for service provider portability (Query on release and Dropback). Tech. rep., International Telecommunication Union, March 1999.
- [6] A Global Perspective on Number Portability, May 2004. Syniverse Technologies Inc.
- [7] Number Portability (NP). http://www.verisign.com/stellent/groups/public/documents/white_paper/001950.pdf, 2004. Verisign Inc.

- [8] Dryburgh, L., and Hewett, J. Signaling System No.7 (SS7/C7): Protocol, Architecture, and Services. Cisco Press, 2005.
- [9] Dzunic, A. Operator Number Portability in Swiss Fixed Telephone Networks. In 15th Telecommunications forum TELFOR (November 2007).
- [10] Foster, M., McGarry, T., and Yu, J. Number Portability in the Global Switched Telephone Network (GSTN): An Overview. <https://tools.ietf.org/search/rfc3482>, 2003.
- [11] ITU. Number portability Capability set 1 requirements for service provider portability (All call query and onward routing). Tech. rep., International Telecommunication Union, May 1998.
- [12] Ivček, M. ENUM based Number Portability in VoIP and IMS Networks. http://www.ericsson.com/hr/about/events/archieve/2007/mipro_2007/mipro_1205.pdf, 2007.
- [13] Lin, Y., and Rao, H. Number Portability for Telecommunication Networks. IEEE Network 13 (January/February 1999), 56–62.
- [14] Medhi, D. Routing Management in the PSTN and Internet: A Historical Perspective. Journal of Network and Systems Management 15, 4 (December 2007), 503–523.
- [15] Medhi, D., and Ramasamy, K. Network Routing: Algorithms, Protocols, and Architectures. Morgan Kaufmann Publishers, 2007.
- [16] Medhi, J. Stochastic Models in Queueing Theory. Academic Press, 1991.

- [17] Scoggins, S., Scoggins, M., and Stach, J. A Teletraffic simulator for circuit switched and signaling intelligent network with SS7. In Proc. of 1991 Winter Simulation Conference, pp. 688 – 694.
- [18] Tirana, P. Private Communication, 2010. private communication.
- [19] Unger, B., Goetz, D., and Maryka, S. Simulation of SS7 Common Channel Signaling. IEEE Communication Magazine 32 (March 1994), 52–62.

VITA

Xuan Liu was born on June 29, 1985 in Wuhan in Hubei Province, China. She was educated in local public schools and graduated from Shuiguohu High School in 2003. After graduating from public school, she attended China University of Geosciences-Wuhan at Wuhan in Hubei, China, and graduated in July 2007 with a Bachelor degree of Science in Communication Engineering.

After obtaining an undergraduate degree, in August 2007, she joined Masters in Computer Science in University of Missouri–Kansas City at Kansas City, Missouri. In August 2010, she joined the Interdisciplinary PhD program in University of Missouri–Kansas City with Telecommunication and Computer Network as her Coordinating discipline and Computer Science as her Co-discipline, respectively.

Upon completion of her master degree requirements, she plans on continuing studying on her PhD program at University of Missouri-Kansas City at Kansas City, Missouri.